

# Machine and Handwheel Handles

## Taper Grip Handle fixed

METRIC  
Parts



Style C  
with molded thread

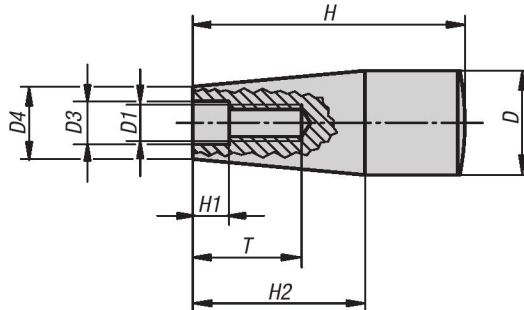

Style E  
with threaded bushing

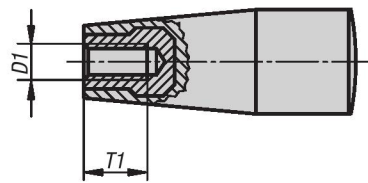

Style F  
with external thread

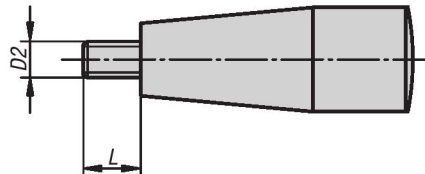

**Material:**

Black duroplastic PF 31, threaded bolt or bushing in galvanized steel, style E bushing in copper-plated steel or brass

**Type:**

High-polish finish.

**Part Number Example:**

K0172.106

**On request:**

Other colors.

### KIPP Taper Grip Handles with internal thread, metric

Item No.	Style	D	D1	D3	D4	H	H1	H2	T	T1
K0172.106	C	17	M6	6,2	15	45	2	26	14	-
K0172.108	C	17	M8	8,2	13	45	2	26	16	-
K0172.1081	C	23	M8	8,5	18	61	2	38	24	-
K0172.110	C	29	M10	10,5	21	71	3,5	42	28	-
K0172.205	E	17	M5	-	15	45	-	26	-	10
K0172.206	E	17	M6	-	15	45	-	26	-	9
K0172.208	E	23	M8	-	18	61	-	38	-	14
K0172.2081	E	28	M8	-	21	71	-	42	-	14

### KIPP Taper Grip Handles with external thread, metric

Item No.	Style	D	D2	D4	H	H2	L
K0172.306	F	17	M6	15	45	26	18
K0172.308	F	23	M8	18	61	38	12
K0172.310	F	29	M10	21	71	42	20