

TECHNICAL APPENDIX

Manual Clamping Technology

Selecting The Proper DE-STA-CO Clamp

The information contained in this catalog is designed to help you select the right clamp to accomplish your job. DE-STA-CO distributor personnel, as well as DE-STA-CO's Technical Service department, are qualified and willing to offer assistance in special or unusual applications. For most ordinary applications, however, consideration of the following points will lead to the proper clamp selection

- Size and shape of the parts to be held.
- Uniformity of part size (Should you consider a spring-loaded spindle to compensate for uneven parts?)
- Holding capacity required
- Strength and dexterity of the operator
- Operator's position (Should you use horizontal or vertical handle models?)
- Frequency of operation (Should you plan for a temporary or permanent fixture?)
- Time cycle of operation (Should you consider a turntable or conveyor set-up if curing time is required?)
- Cycling time and sequence (Should you consider air-operated models that can be operated faster and in sequence?)
- Environment (Should a stainless steel model be considered?)

Processing Applications

Remember, the same toggle action force multiplying principle can be applied to other tasks besides holding. Certain DE-STA-CO models can be used to position parts, power fixtures or perform mechanical functions such as piercing sheet metal, staking rivets or locating.

OEM Applications

DE-STA-CO clamps provide ready-made, compact devices for moving or holding components. A little imagination will often show the product designer a way to obtain motion or locking force with no tooling costs and often at less cost than custom designed components. Thousands of DE-STA-CO clamps will be found installed as original equipment for cleanout door latches, wheel locks, positioning devices, etc.

Safety

Our concern is not only the constant high quality of our products, but also their fail-safe and foolproof handling. The knowledge gathered since 1936 guarantees a developed, safe and high-quality clamping unit.

A certain clamping force will be necessary to safely hold a part. This force is determined by taking the following into account:

- (A) the part material: such as, steel, wood, plastic or glass, etc.
- (B) the surface finish of the part: such as, polished, hard or soft, etc.
- (C) the machining or assembly operation: such as, milling, welding, drilling, bonding, joining or sealing a mold, etc.

In order to ensure clamp strength is not compromised, use all the mounting holes provided.

Red handle grips are provided on each model. Users should only locate their hand in this area when operating the clamp, thus reducing the possibility of injury.

Safety Handle

This ergonomic handle provides greater operator comfort.



Safety Feature

This safety link prevents accidental injury to an operator when opening the clamp.

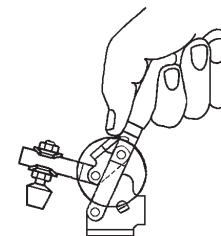

Clamp Series 201, 202, 207, 210, 247, 267

Safety Distance

Exclusive handle design gives more hand clearance between bar and handle when clamp is in fully open position.

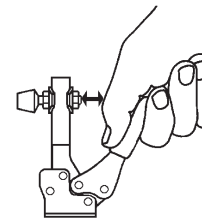

Clamp Series 213, 217, 227, 237, 245

TECHNICAL APPENDIX

Manual Clamping Technology

DE-STA-CO Toggle-Lock Plus Clamps

We have taken several of our most popular toggle clamps and have added a locking release lever for improved safety. The locking release lever helps ensure that the over-center locking condition is maintained. In order to unlock each clamp, the locking lever must first be released. The additional locking feature expands the range of applications where DE-STA-CO clamps can be used. If a clamp application warrants concerns over accidental or unintentional opening, then a DE-STA-CO Toggle-Lock Plus clamp is right for the job.

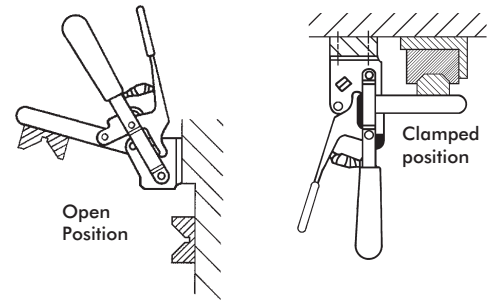

The most important models at a glance:

Vertical hold-down clamp

- Handle is vertical in clamped position
- Holding capacities up to 22,25kN [5000lbf.]
- Opening angle between 65° and 215°

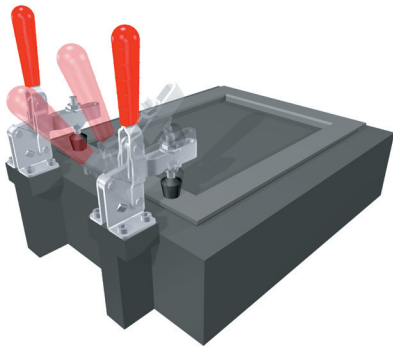

Straight line action clamp

- Forward movement of the handle pushes the plunger into the forward position
- Can be used as a push clamp and pull clamp, locking in two positions
- Holding capacities of 445N-71,2kN [100–6,000lbf.]

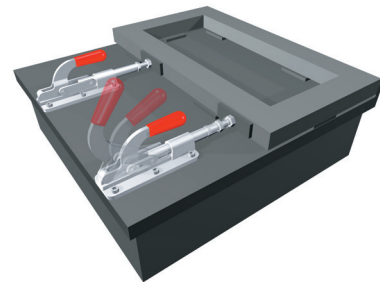

Horizontal hold-down clamp

- Very low profile
- Handle is horizontal in the clamped position
- Holding capacities up to 7,5kN [1,680lbf.]
- Opening angle between 90° and 105°

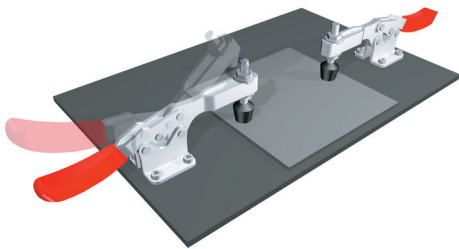

Latch clamp

- Convenient one-hand operation due to the patented thumb control lever
- Compact models
- Holding capacities up to 33,4kN [7,500lbf.]

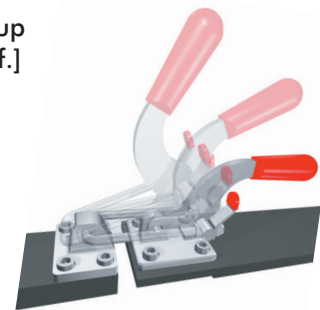

Plier clamp

- Flexible clamping and fixturing
- Also equipped with quick release lever
- Holding capacities 450N-5340N [100-1200lbf.]

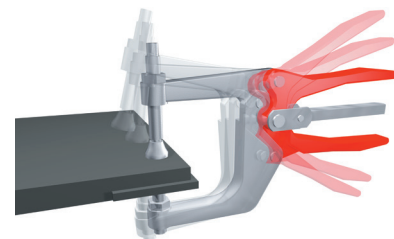

TECHNICAL APPENDIX

Manual Clamping Technology

How Toggle Action Works

Toggle action clamps operate through a linkage system of levers and pivots. The fixed-length levers, connected by pivot pins, supply the action and clamping force. Toggle action has an over-center lock point which is a fixed stop and linkage. Once in the over-center position, the clamp cannot move or unlock unless the linkage is moved. All types of toggle clamps have this same action, just oriented differently.

Toggle Action Force Factors

The maximum clamping or exerting force developed in any toggle action clamp is attained when the three pivot points of the mechanism are in a straight line. While this is theoretically true, it makes no allowance for vibration and intermittent load conditions found in industrial applications. Such conditions would soon unlock an improperly designed clamp. The proper amount of over-center travel to produce maximum holding force and yet ensure positive locking is a carefully calculated and controlled dimension developed by years of experimentation and experience.

Throughout this catalog each clamp is rated with its "holding capacity." This is the maximum load or force the clamp will sustain in the closed and locked position without permanent deflection. Exerting forces applied as the clamp closes are less than the holding capacity, and are dependent on variables such as the position of the operator's hand on the handle; amount of force applied; and position of the spindle on the bar.

What about the forces?

In the case of clamping products, a clear distinction must be made between exerting forces and holding capacities. Here are the essential features:

Exerting or Clamping Force

The "exerting force" of our air toggle clamps is well defined and can be found on page 7. Manually operated clamps present a series of variables to determine actual exerting force.

These variables are:

- the force exerted on the handle by the operator;
- the point on the handle where this force is applied;
- the mechanical advantage in the linkage; and
- the point on the work holding bar where the force will be measured. As a general rule, the mechanical advantage available throughout the line ranges 2:1 to 10:1

Toggle Action Principle

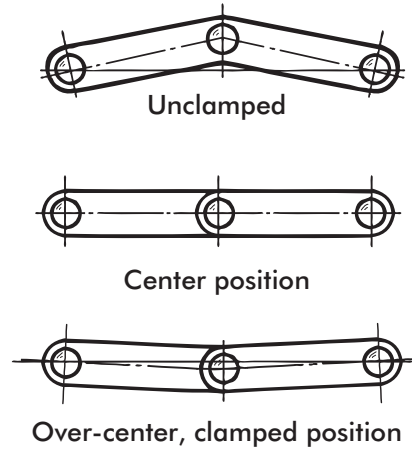

Toggle Action Clamps Compared with Cam Action Clamps

Cam action uses frictional force to effect a locking condition between the cam surface on the bar and the follower on the handle. Toggle action clamps have many advantages over cam action clamps, mainly because cam action clamps allow some movement while clamping. Toggle action clamps thus provide a more consistent clamping point, can be manufactured from inexpensive materials, and are available in stainless steel for outdoor or corrosive applications. If the material being clamped has a variable thickness, however, a cam action clamp has the ability to better accommodate this application.

Holding Capacity

The "holding capacity" of DE-STA-CO toggle clamps has been determined by actual tests. It is defined as the maximum amount of force which may be applied to the work holding bar, in the closed position, without creating permanent deformation of the clamp components. This maximum force is measured at a point closest to the base and diminishes as the spindle approaches the end of the bar. The ratings for holding capacity are maximum and should not be exceeded. These values include a safety factor.

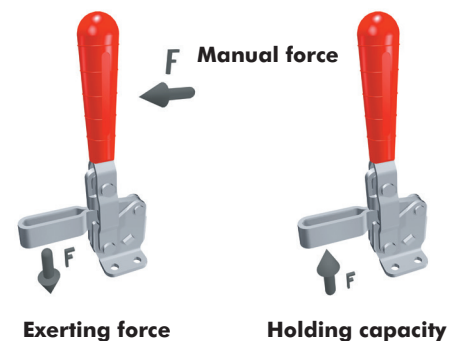

TECHNICAL APPENDIX

Manual Clamping Technology

Calculating Exerting or Clamping Force

The table below depicts holding capacity (HC) and clamping force (EF) data for a typical manual clamp. The clamping force (EF) is expressed as a ratio of the force that is applied to the clamp handle (AF). In this example, either 10:1 or 5.3:1 depending upon position of the clamping point on the clamp arm. That is, at position X1, the maximum clamping force (EF) that can be generated is 10 times the force that is applied to the clamp handle.

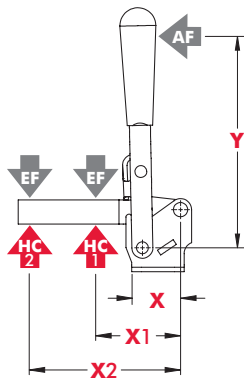

Model	X	X1	X2	Y	±HC1	±HC2	±EF(X1):AF	±EF(X2):AF
2007-()	[1.59] 40,5	[1.95] 49,5	[3.92] 99,5	[5.16] 131	[1000lbf.] 4450N	[470lbf.] 2090N	10:1	5.3:1

Dimensions shown "mm [inch]" ± HC = Holding Capacity, EF = Exerting Force, AF = Applied Force
Refer to page MC-TEC-4 for additional information.

Examples:

- Find the force (AF) the operator would have to apply to the clamp to generate a clamping force of 400N [90lbf.] at the end of the clamp arm (X1).

$$AF = 400 \div 10 = 40N [9lbf.]$$

- What is the maximum clamp force that can be generated at X2 if the operator is only able to apply 20N [4.5lbf.] to the clamp handle?

$$EF = 20 \cdot 5,3 = 106N [24lbf.]$$

Calculating Holding Capacity

The holding capacity (HC) ratings shown in the table are in relation to the pivot point of the clamping arm. This is useful in estimating the holding capacity at an intermediate clamping point along the arm, or at a point beyond the length of the standard clamping arm.

Examples:

- Find the maximum holding capacity if the clamping point is 40mm [1.5in.] from the front of the base of the clamp.
 - Step 1 – find the clamping distance from the clamping point to the pivot point

$$X_c = 40\text{mm} + X = 40\text{mm} + 40,5\text{mm} = 80.5\text{mm}$$

- Step 2 – express the holding capacity as a moment

$$M = X1 \cdot HC1 = 49,5\text{mm} \times 4450\text{N} = 220275 \text{ N}\cdot\text{mm}$$

- Step 3 – calculate the holding capacity at Xc

$$HC = M \div X_c = 220275 \div 80,5 = 2736\text{N} [615\text{lbf.}]$$

- Find the maximum holding capacity if the clamp arm is extended by 25mm [1in.]

$$X_c = 25 + X2 = 25 + 99,5 = 124,5\text{mm}$$

$$M = X2 \cdot HC2 = 99,5\text{mm} \cdot 2090\text{mm} = 207955 \text{ N}\cdot\text{mm}$$

$$HC = M \div X_c = 207955 \div 124,5 = 1670\text{N} [375\text{lbf.}]$$

TECHNICAL APPENDIX

General Specifications

Material, finishes, treatments, etc. of DE-STA-CO products are changed from time-to-time to improve performance or reliability. These items are, naturally, subject to change without notice. In the interest of catalog longevity, they are not discussed in detail throughout the catalog. As of the date of going to press, however, the following specifications apply unless noted otherwise:

Materials

In general, light and medium duty clamp components are made from low carbon cold-rolled steel. Materials for other models vary depending upon the clamp model and specific engineering requirements. These materials include low to medium carbon steel castings and forgings, heat treated as necessary to obtain the desired mechanical properties.

Pivot pins for most light and medium duty clamps are cold headed from precision cold drawn type 430, EN 1.4016 stainless steel. Pins for heavy duty models are made from heat treated alloy steel. Bushings used in select models are made from low carbon, case-hardened steel for wear resistance and serrated on the outside diameter to prevent rotation.

Ergonomic grips are made from an oil-resistant plasticized PVC compound, while some handles and locking levers covered with plastisol dipping.

Stainless Steel

Stamped components in our stainless steel clamps are made from type 302/304, 1.4300 or 1.4301 (or comparable) stainless steel, annealed & cold rolled. Machined stainless steel components are type 303, EN1.4305 (or comparable).

Finishes

Most manual toggle clamps are electro-plated zinc per ASTM B633-98, SC1, type2 (or comparable). Most cast or forged components are finished black oxide with light oil to add corrosion protection.

Mounting

To properly secure the clamp to the mounting surface and achieve the clamp's rating, all mounting holes provided must be used.

Modifications

Making changes to the clamp may affect the performance of the product. The life expectancy of a clamp is dependent upon many factors, including alterations to the clamping bar, handle, or the addition of any tooling. Manual clamps are rated using hand power to actuate them. The use of "cheater bars" or hammers to impact the opening or closing of the clamp is expressly prohibited.

Maintenance

Manual clamps are generally maintenance free; however, lubrication of pivot points will extend the life of the clamp dramatically. Clamps are shipped from the factory with a light coating of oil, occasional lubrication with a lightweight machine oil at pivot points is recommended. A typical oil specification is ISO grade 22 or 46 (SAE No. 10W or 20).

Temperature Limits

DE-STA-CO manual clamps are intended to be used at normal ambient temperatures. These limits are intended to be guidelines and you should contact DE-STA-CO if you have a specific application concern. For low-carbon steel clamps: -65°F(-54°C) to 480°F(250°C); for stainless steel (type 304): up to 750°F (400°C). These values are based upon maintaining the tensile strength of the material, due to the many variables associated with operating clamps at elevated temperatures service life may be affected. Bear in mind that for low carbon steel parts that are zinc plated, the plating has a useful service temperature of up to 250°F(120°C), but corrosion inhibiting properties degrade above 140°F(60°C). These temperatures are NOT inclusive of any plastic grip, vinyl dipping, rubber spindle accessory, pneumatic, or hydraulic actuator.

TECHNICAL APPENDIX

Pneumatic Clamping Technology

End position sensing of pneumatic clamps for automated production.

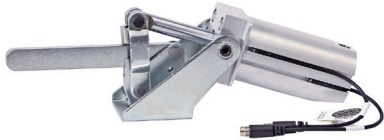

Model 807-S with 2 integral groove mounted sensors (order separately)

Exerting Force vs. Holding Capacity

Due to the nature of the toggle action within the clamping mechanism combined with the line pressure of the cylinder, care should be taken in setting up Pneumatic Toggle Clamps.

The clamping force of a given pneumatic toggle clamp is determined by two factors - adjustment of the clamping spindle and the line pressure in the cylinder. If the line pressure remains constant, then the clamping force is solely determined by the vertical adjustment of the spindle. If the spindle is improperly adjusted, the clamp is capable of creating a clamping force that exceeds the rated holding capacity.

As a result of this condition care must be taken by properly adjusting the spindle OR by regulating the inlet pressure to the cylinder in order to insure the clamp does not exert a force higher than it's rated holding capacity.

Please consult the table and formulae on the next page. The Max M.A. is the highest mechanical advantage the clamp can create at the optimum spindle height while still toggle-locking.

Remote control and end position sensing

A particularly interesting advantage of DE-STA-CO power clamps is the fact that they may be mounted on rather inaccessible places of clamping fixtures and they may be operated simultaneously while being controlled by a control valve. Power clamps with an end position sensing system allow fully automated operation with in controlled manufacturing processes.

Safety

DE-STA-CO power clamps are based on the toggle action principle (exceptions will be mentioned separately) and offer the same safety advantages as DE-STA-CO manual clamps: no risk of accidental opening of the clamp arm - even in case of a sudden pressure drop.

The toggle action principle with over-center locking guarantees safety during operation and protects the parts from damage. (Provided that the power clamps are mounted correctly and the air supply is reliable.)

Note: Most pneumatic products are now supplied with a magnetic ring on the piston as a standard feature for sensing the position of the cylinder (open/closed).

Pneumatic diagram

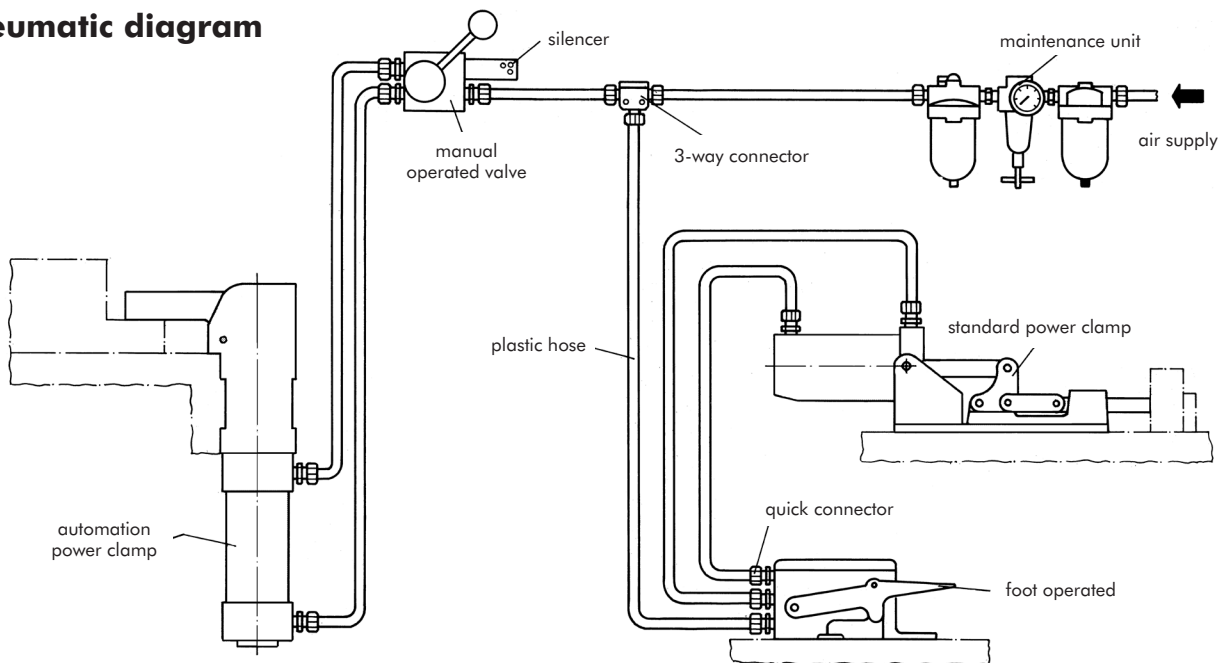

TECHNICAL APPENDIX

Specifications

Model no.	Cylinder Bore		Rod Diameter		Cylinder Area (Clamping Stroke)		Cylinder Area (Opening Stroke)		Max. Mechanical Advantage (M.A.)		Distance From Pivot				Holding Capacity				Max Inlet Pressure at Max M.A.*				Max. Clamping Force at 5 bar [72 psi]			
											A		B		A		B		A		B		A		B	
	(in)	(mm)	(in)	(mm)	(in ²)	(mm ²)	(in ²)	(mm ²)	A	B	(in)	(mm)	(in)	(mm)	(lbf.)	(N)	(lbf.)	(N)	(PSIG)	(bar)	(PSIG)	(bar)	(lbf.)	(N)	(lbf.)	(N)

Hold Down Clamps

802-U	1.26	32	0.47	12	1.25	804	1.07	691	5.0	2.6	1.25	31.8	2.25	57.2	200	890	110	489	32	2.2	34	2.3	450	2010	234	1045
807-S	1.26	32	0.47	12	1.25	804	1.07	691	6.0	2.0	2.00	50.8	5.00	127.0	500	2220	260	1160	67	4.6	104	7.2	540	2412	180	804
807-U	1.26	32	0.47	12	1.25	804	1.07	691	6.4	3.3	2.00	50.8	3.75	95.3	375	1670	275	1220	47	3.2	67	4.6	576	2573	297	1327
810-S	1.57	40	0.63	16.0	1.95	1257	1.64	1056	5.0	2.9	2.38	60.5	5.31	134.9	750	3340	500	2220	77	5.3	89	6.1	702	3143	407	1823
810-U	1.57	40	0.63	16.0	1.95	1257	1.64	1056	6.1	2.9	2.38	60.3	4.88	123.8	600	2670	290	1290	50	3.5	51	3.5	856	3834	407	1823
812-U	0.75	19	0.25	6.4	0.4	258	0.39	253	4.3	2.9	1.25	31.8	2.25	57.2	100	440	55	245	53	3.6	43	3.0	136	613	92	413
846	1.57	40	0.63	16.0	1.95	1257	1.64	1056	5.6	3.5	2.25	57.2	3.25	82.6	750	3340	520	2310	69	4.7	76	5.3	786	3520	491	2200
847-S	2.05	50	0.63	16.0	3.29	2124	2.98	1923	4.0	1.8	3.25	82.6	6.50	165.1	1000	1118	650	2890	76	5.2	110	7.6	948	4248	426	1912
847-U	2.05	50	0.63	16.0	3.29	2124	2.98	1923	4.0	1.9	3.25	82.6	6.25	158.8	1000	4450	480	2135	76	5.2	77	5.3	948	4248	450	2018
858	2.48	63	0.98	25.0	4.83	3117	4.07	2626	4.4	2.3	3.00	76.2	7.00	177.8	4000	17800	2000	8900	145**	10.0**	145**	10.0**	1530	6857	800	3585
8021	1.26	32	0.47	12.0	1.07	691	1.25	8.4	2.2	1.3	1.70	43.2	2.60	66.0	390	1735	255	1135	145**	10.0**	145**	10.0**	169	760	100	449
8071	1.57	40	0.63	16.0	1.64	1056	1.95	1257	4.2	2.4	2.25	57.2	3.25	82.6	450	2000	310	1380	65	4.5	79	5.4	496	2218	283	1267
8101	2.05	50	0.63	16.0	2.98	1923	3.29	2124	2.3	1.2	2.35	59.7	4.45	113.0	700	3110	370	1645	103	7.1	105	7.3	491	2202	253	1135
817-S	1.26	32	0.47	12.0	1.25	804	1.07	691	4	2.25	2.75	69.9	4.94	125.5	450	2000	200	890	90	6.2	64	4.4	360	1608	225	1005
817-U	1.26	32	0.47	12.0	1.25	804	1.07	691	4.1	2.5	2.75	69.9	5.00	127.0	375	1670	200	890	73	5.1	64	4.4	369	1648	225	1005
827-S	1.57	40	0.63	16.0	1.95	1257	1.64	1056	3.5	2	2.50	63.5	5.30	134.6	700	3110	330	1470	103	7.1	85	5.8	491	2200	281	1257
827-U	1.57	40	0.63	16.0	1.95	1257	1.64	1026	3.5	2.2	2.13	54.1	3.25	82.6	600	2670	390	1735	88	6.1	91	6.3	491	2200	309	1383
868	2.48	63	0.98	25.0	4.83	3117	4.07	2626	4.9	2.3	5.00	127.0	8.25	209.6	4000	17800	2400	10675	145**	10.0**	145**	10.0**	1704	7637	800	3585

Model no.	Cylinder Bore		Rod Diameter		Cylinder Area (Clamping Stroke)		Cylinder Area (Opening Stroke)		Max. Mechanical Advantage (M.A.)	Holding Capacity				Max Inlet Pressure at Max M.A.			
	(in)	(mm)	(in)	(mm)	(in ²)	(mm ²)	(in ²)	(mm ²)		(lbf.)	(N)	(PSIG)	(bar)				

Straight Line Action Clamps

803	1.26	32.0	0.47	12.0	1.25	804	1.07	691.2	7.5					600	2670	64	4.4	675	3015
816	0.75	19.1	0.25	6.4	0.44	285	0.39	253.4	7.7					100	400	30	2.0	244	1097
830	1.57	40.0	0.63	16.0	1.95	1257	1.64	1055.6	5.7					2500	11100	145**	10.0**	800	3582
850	2.05	52.0	0.63	16.0	3.29	2124	2.98	1922.7	5.2					16000	71200	145**	10.0**	1232	5522
8031	1.13	28.6	0.38	9.5	0.99	641	0.88	570.0	10.25					2000	890	145**	10.0**	731	3285

* Maximum cylinder pressure is 145 PSIG (10 bar). Never exceed this value

**Maximum inlet pressure in conjunction with maximum mechanical advantage does not exceed holding capacity. Do not exceed maximum cylinder pressure

Formula for calculating maximum allowable inlet pressure:

$$\text{Maximum Line Pressure} = \text{Holding Capacity} \div (\text{Cylinder Area} \times \text{Mechanical Advantage})$$

Formula for calculating max. exerting force:

$$\text{Exerting Force} = \text{Inlet Pressure} \times \text{Mechanical Advantage} \times \text{Cylinder Area}$$

Example for Model 830

Holding Capacity = 11100N [2500lbf.]

Inlet Pressure 5bar (0,5 N/mm²) [72psig]

Cylinder Area = 1257mm² [1.95in²]

Maximum Line Pressure = 11100 ÷ (1257 X 5.7) = 1,5 N/mm² = 15bar

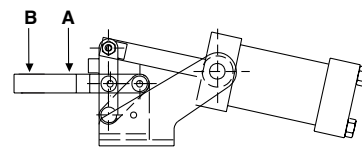

Spindle position to determine mechanical advantage.

NOTE: This exceeds the maximum allowable cylinder pressure of 10bar

