

# 860, 861, 890, 891, 1000, 1001 SERIES

## Pneumatic Power Clamps | Ordering Information

860

Base Model	Description
<b>860</b>	2 in. Cylinder Bore Size with Vertical Clamp Arm
<b>861</b>	2 in. Cylinder Bore Size with Horizontal Clamp Arm
<b>890</b>	2.5 in. mm Cylinder Bore Size with Vertical Clamp Arm
<b>891</b>	2.5 in. Cylinder Bore Size with Horizontal Clamp Arm
<b>1000</b>	3.25 in. Cylinder Bore Size with Vertical Clamp Arm
<b>1001</b>	3.25 in. Cylinder Bore Size with Horizontal Clamp Arm

Sensors	Description (order separately)
<b>BIM-IKE-AP</b>	Magnetic Sensor, 2 pieces required
<b>810151</b>	Magnetic Sensor, 2 pieces required
<b>810153</b>	Magnetic Sensor, 2 pieces required
<b>810155</b>	Magnetic Sensor, 2 pieces required
<b>810157</b>	Magnetic Sensor, 2 pieces required

See page PC-PPC-66 for sensor specifications.

Seal Kit	Description (order separately)
<b>8610100</b>	Seal Kit for Model 860, 861
<b>8910100</b>	Seal Kit for Model 890, 891
<b>10010100</b>	Seal Kit for Model 1000, 1001

Cylinder	Description (order separately)
<b>865133-MR</b>	Replacement Cylinder for Model 860
<b>865132-MR</b>	Replacement Cylinder for Model 861
<b>895133-MR</b>	Replacement Cylinder for Model 890
<b>895132-MR</b>	Replacement Cylinder for Model 891
<b>1005134-MR</b>	Replacement Cylinder for Model 1000
<b>1005133-MR</b>	Replacement Cylinder for Model 1001

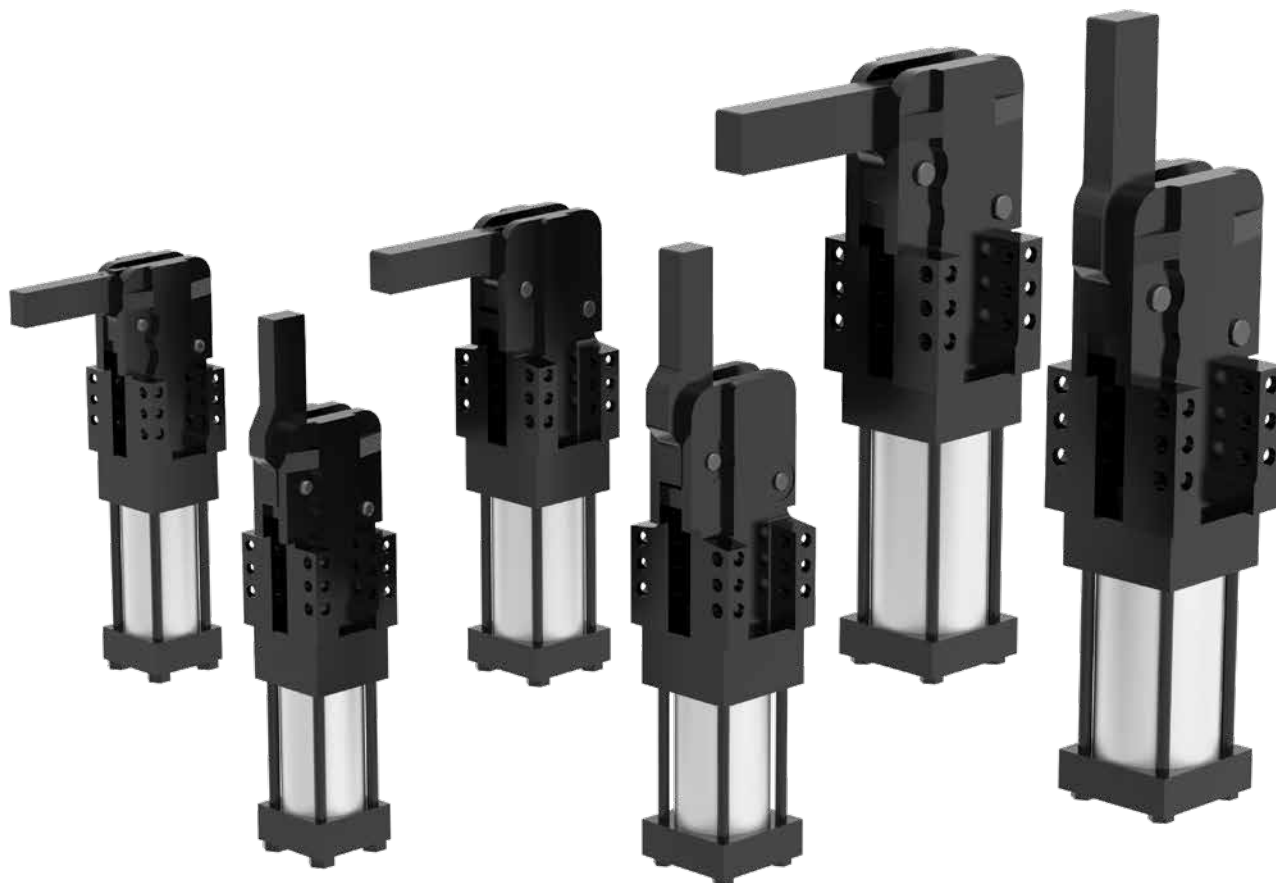

861

Max Holding Torque  
380 Nm  
Max Clamping Torque  
120 Nm at 5bar

891

Max Holding Torque  
1300 Nm  
Max Clamping Torque  
270 Nm at 5bar

1001

Max Holding Torque  
1800 Nm  
Max Clamping Torque  
420 Nm at 5bar

860

Max Holding Torque  
380 Nm  
Max Clamping Torque  
120 Nm at 5bar

890

Max Holding Torque  
1300 Nm  
Max Clamping Torque  
270 Nm at 5bar

1000

Max Holding Torque  
1800 Nm  
Max Clamping Torque  
420 Nm at 5bar

# 860, 861, 890, 891, 1000, 1001 SERIES

Pneumatic Power Clamps | Dimensions | Technical Specifications

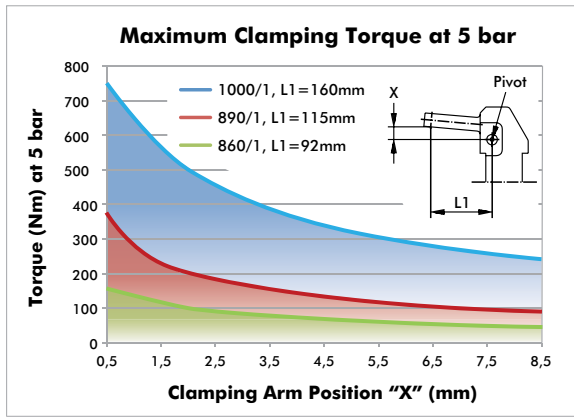

Model	Cylinder Ø mm [in]	Opening Angle	Weight kg [lbs]
860	[2.00]	96°	[8.58]
861	50,8	119°	3,9
890	[2.50]	96°	[16.06]
891	63,5	119°	7,3
1000	[3.25]	96°	[29.70]
1001	82,5	119°	13,5

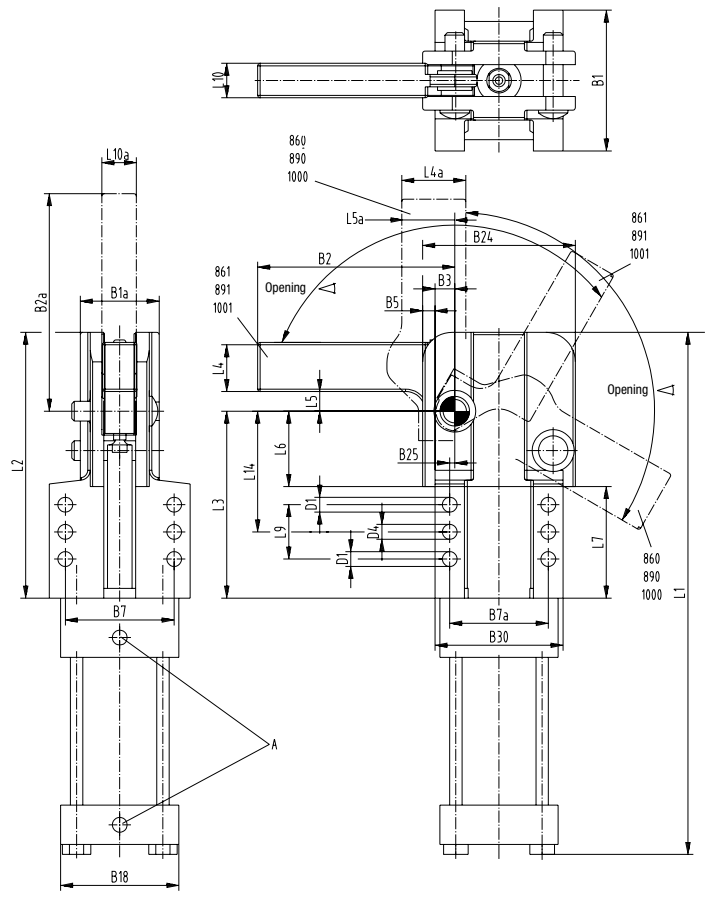

Power by compressed air, max. 6 bar  
Operation with oil-free air is permissible.

Information vor machining of clamp arm: Steel 1.0726

Model	A	B1	B1A	B2	B2A	B3	B5	B7	B7A	B18	B24	B25	B30
860	G1/8	[2.94]	[1.75]	-	[5.44]	[0.41]	[0.25]	[2.31]	[2.19]	[2.5]	[3.31]	[0.09]	[2.81]
861		74,7	44,5	[4]	138,2	10,4	6,4	58,7	55,6	63,5	84,1	2,3	71,4
890	G1/8	[3.56]	[2]	-	[6.57]	[0.5]	[0.31]	[2.76]	[2.5]	[3]	[3.87]	[0.13]	[3.25]
891		90,4	50,8	5.06	166,9	12,7	7,9	70,1	63,5	76,2	98,3	3,3	82,6
1000	G1/8	[4.5]	[2.62]	-	[9]	[0.63]	[0.44]	[3.5]	[3.5]	[3.75]	[5.38]	[0.13]	[4.5]
1001		114,3	66,5	7	228,6	16	11,2	88,9	88,9	95,3	136,7	3,3	114,3

Model	ØD1	ØD4	L1	L2	L3	L4	L4A	L5	L5a	L6	L7	L9	L10	L10a	L14
860	[0.34]	[0.31]	[12.44]	[5.75]	[4.06]	-	[1.12]	--	[0.69]	[1.44]	[2.5]	[1.25]	[0.62]	[0.62]	[2.5]
861	8,6	7,9	316	146,1	103,1	[1.13]	-	[0.4]	--	36,6	63,5	31,8	15,7	15,7	63,5
890	[0.41]	[0.38]	[13.37]	[6.75]	[4.75]	-	[1.25]	-	[0.84]	[1.75]	[2.65]	[1.38]	[0.81]	[0.81]	[3.06]
891	10,4	9,7	339,6	171,5	120,7	[1.25]	-	[0.5]	--	44,5	67,3	35,1	20,6	20,6	77,7
1000	[0.53]	[0.5]	[17.51]	[9.25]	[6.25]	-	[1.75]	-	[1.37]	[2.25]	[3.96]	[2]	[1]	[1]	[3.75]
1001	13,5	12,7	444,8	235	158,8	[1.75]	-	[0.88]	--	57,2	100,6	50,8	25,4	25,4	95,3