

ROTARY PART HANDLER

Features, Table of Contents



Features:

The **CAMCO RPP Cambot® Rotary Parts Handler** is designed for high precision and high capacity. This proven design can be used in a wide variety of industries including automotive, packaging and electronics among others. The RPP can be combined with other CAMCO products such as index drives and precision conveyors for a complete, automated system. The RPP is ideal for pick and place applications with features including:

Rugged and precise cam operated mechanisms engineered for a minimum of 8000 hours of maintenance-free life.

Hardened and ground cams drive both the lift and rotary axes.

Preloaded precision cam followers eliminate backlash and ensure smooth movement.

Preloaded taper roller bearings on the cam-shaft (Input Shaft).

Four-point contact preloaded roller bearing on the rotary axis.

All bearings are lubricated by an oil bath.

One-piece lift arm.

Ball bushings (recirculating-ball type) support the main lift shaft and turn the large output surface and ride on hardened shafts for stability and stiffness.

Manufactured in a fully integrated application, design, manufacturing and inspection environment.

Table of Contents

How to Order	IN-RPP-3
300RPP	IN-RPP-5
500RPP	IN-RPP-7
Timing Diagrams.....	IN-RPP-9

ROTARY PART HANDLER

How to Order

RPP Ordering Procedure

1. Model
2. Rotary Motion (degrees)
 - Oscillator or indexer
 - Oscillator: Home at X or Y
 - Indexer: CW or CCW index
3. Lift (inches)
4. Input Shaft: Side 1, Side 2 or Double Input (DI)
5. Mounting Position: 1-6

Reducer Ordering Procedure

1. Reducer Model, Ratio and Mounting Position
2. Motor Adaptor Model
3. Motor size

Input Shaft Configuration

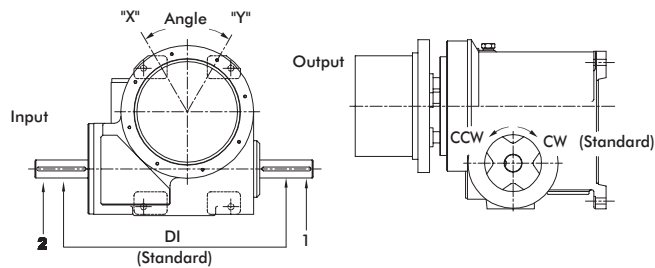

Standard Output Sequence

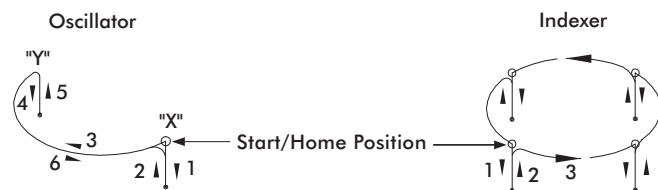

ROTARY PART HANDLER

Rotary Part Handler | Mounting Position

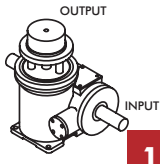
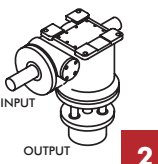
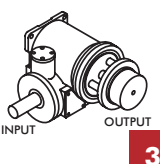
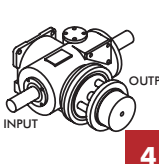
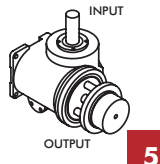
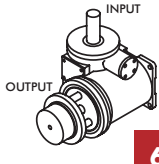
OVOI (output vertical, over input)	OVUI (output vertical, under input)	OHOI (output horizontal, over input)	OHUI (output horizontal, under input)	H-S1-UP (output horizontal, side 1 up)	H-S2-UP (output horizontal, side 2 up)
 1	 2	 3	 4	 5	 6

Gear Reducer Mounting Positions

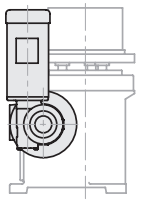
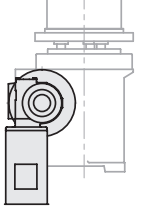
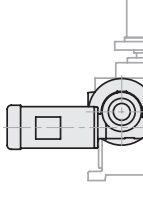
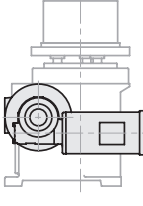
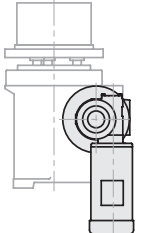
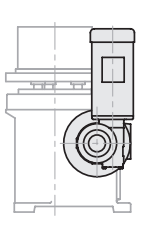
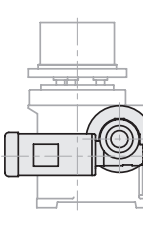
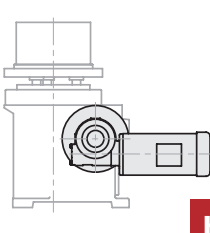
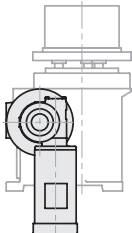
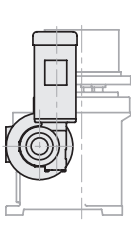
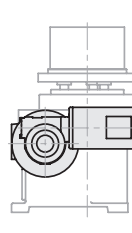
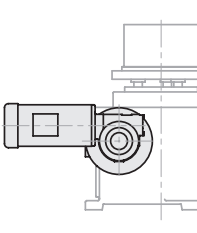
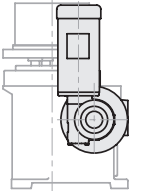
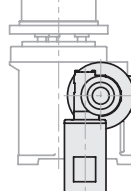
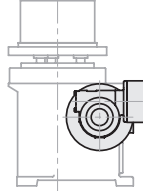
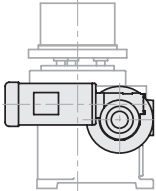
		Mounting "A"		Mounting "B"	
		RH	LH	RH	LH
SIDE 1	 A	 B	 C	 D	
	SIDE 2	 E	 F	 G	 H
		Mounting "C"		Mounting "D"	
		RH	LH	RH	LH
SIDE 1	 J	 K	 L	 M	
	SIDE 2	 N	 P	 R	 S

300RPP SERIES

Rotary Part Handler | Configurations

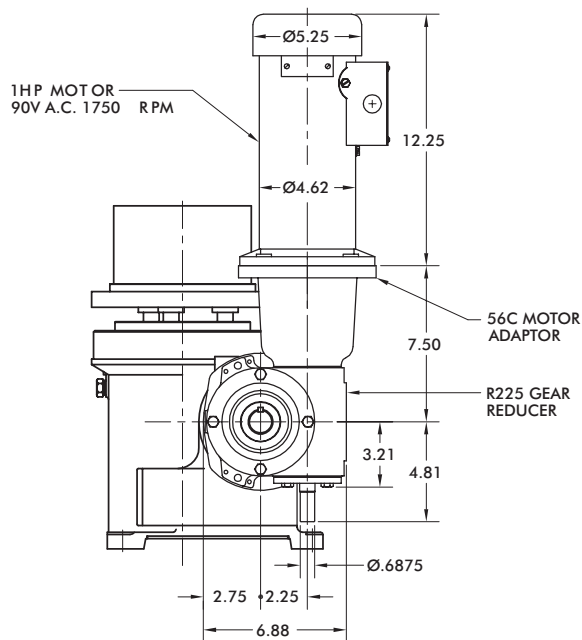
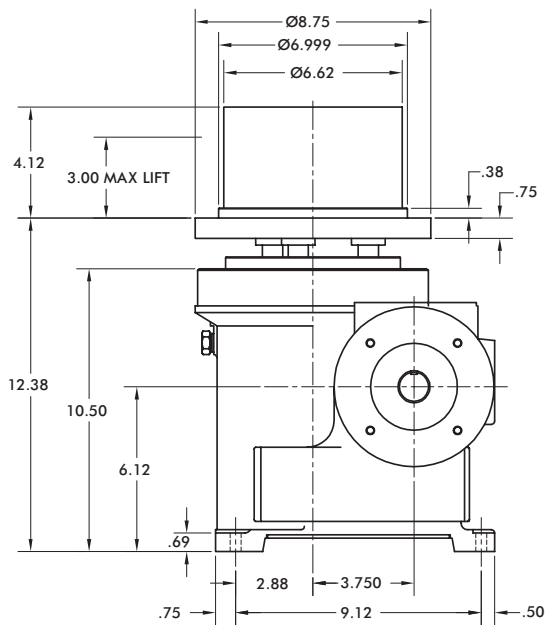
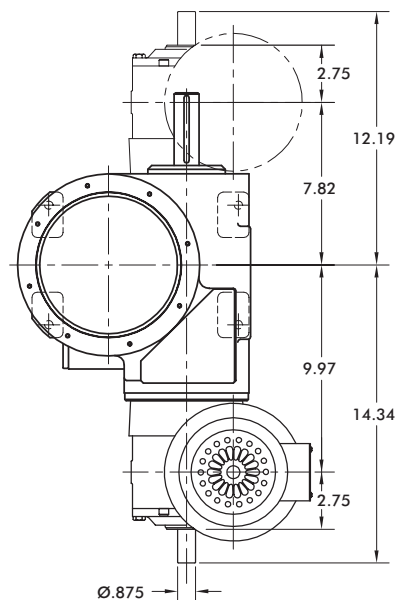
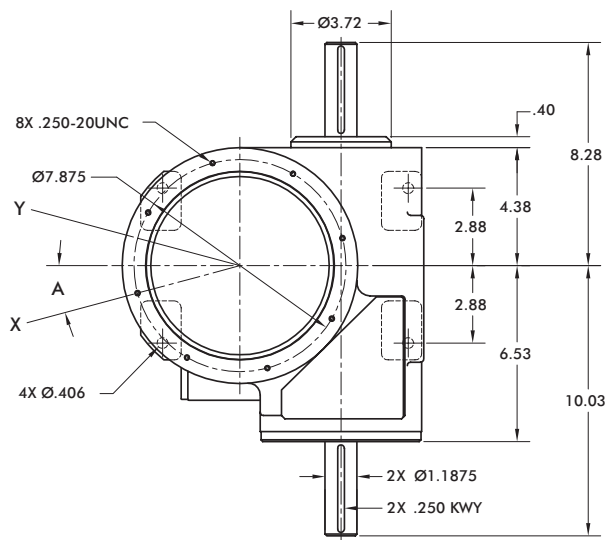

300RPP SERIES

Rotary Part Handler | Features, Options, Technical Information

Oscillating Motion			
Rotation	Angle A	Lift (in.)	Model
120°	0°	1	300RPP120H24-1H24
		2	300RPP120H24-2H24
90°	15°	1	300RPP90H24-1H24
		2	300RPP90H24-2H24
		3	300RPP90H24-3H24
60°	0°	1	300RPP60H24-1H24
		2	300RPP60H24-2H24
		3	300RPP60H24-3H24
45°	22.5°	1	300RPP45H24-1H24
		2	300RPP45H24-2H24
		3	300RPP45H24-3H24

Indexing Motion			
Rotation	Angle A	Lift (in.)	Model
180°	0°	1	300RPP2H24-1H24
		2	300RPP2H24-2H24
		3	300RPP2H24-3H24
120°	0°	1	300RPP3H24-1H24
		2	300RPP3H24-2H24
		3	300RPP3H24-3H24
90°	0°	1	300RPP4H24-1H24
		2	300RPP4H24-2H24
		3	300RPP4H24-3H24
60°	0°	1	300RPP6H24-1H24
		2	300RPP6H24-2H24

Features

- Standard Indexing or Oscillating Motion
- R225 Reducer (Ratios from 5:1 to 60:1)
— 56C Motor Adapter and Coupling
- 1 hp AC Drive Package with Inverter Duty Motor and Inverter Drive (up to 60 cpm)

Optional Accessories

- 1 hp DC Motor
- Varipak DC Motor Control (up to 30 cpm)

Capacity:*

Maximum Mass	150 lbs
Maximum Inertia	1700 lb-in ²

* Note: These values are for speeds of less than 30 rpm, the minimum cam time for rise and rotation, and are for reference only. Each application must be reviewed and approved by CAMCO Engineering.

500RPP SERIES

Rotary Part Handler | Configurations

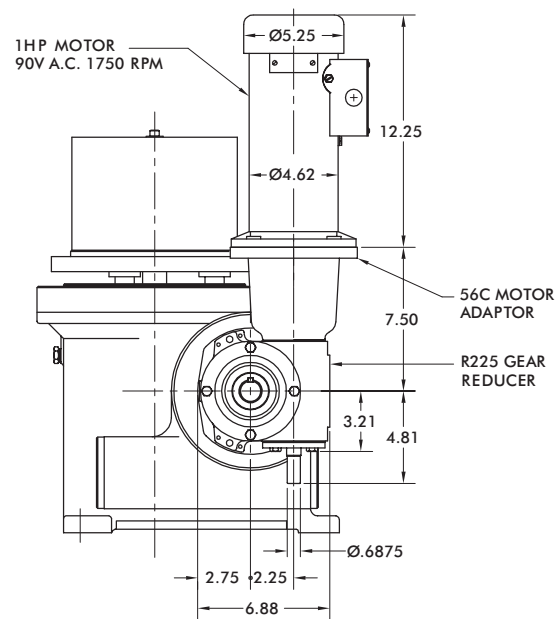
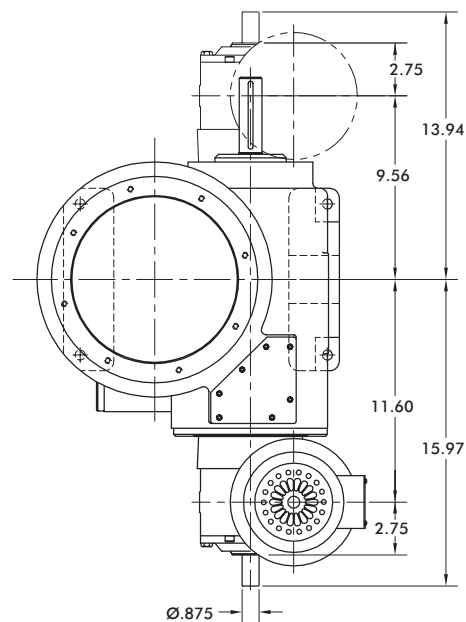
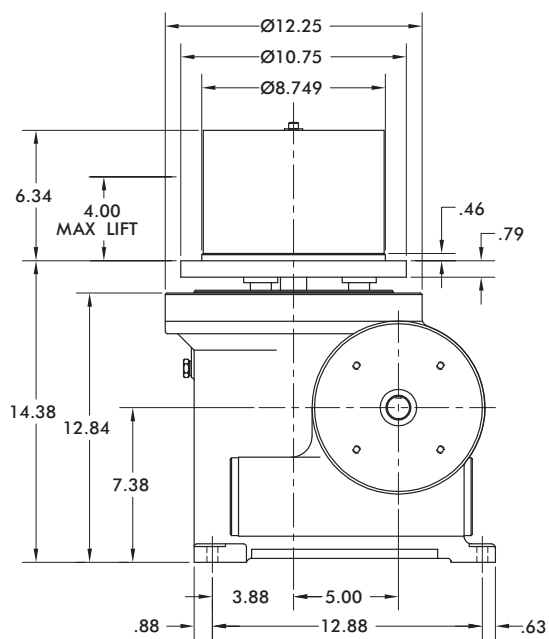
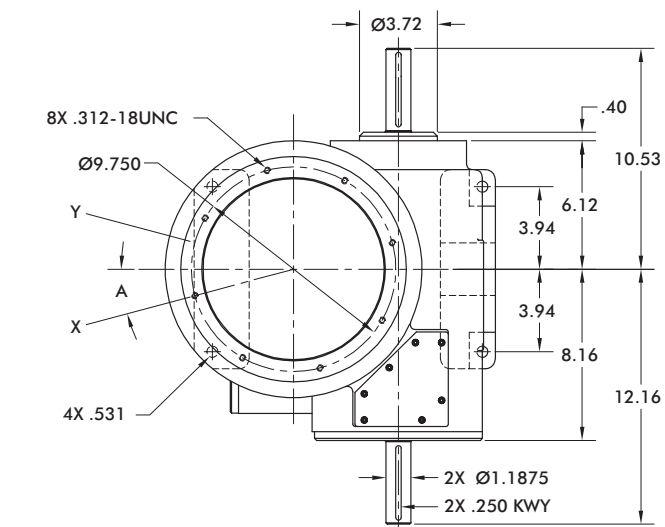

500RPP SERIES

Rotary Part Handler | Features, Options, Technical Information

Oscillating Motion			
Rotation	Angle A	Lift (in.)	Model
180°	0°	2	500RPP2H32-2H32
		3	500RPP2H32-3H32
		4	500RPP2H32-4H32
120°	0°	2	500RPP3H32-2H32
		3	500RPP3H32-3H32
		4	500RPP3H32-4H32
90°	0°	2	500RPP4H32-2H32
		3	500RPP4H32-3H32
		4	500RPP4H32-4H32
60°	0°	2	500RPP6H32-2H32
		3	500RPP6H32-3H32
		4	500RPP6H32-4H32

Indexing Motion			
Rotation	Angle A	Lift (in.)	Model
120°	0°	2	500RPP120H32-2H32
		3	500RPP120H32-3H32
90°	15°	2	500RPP90H32-2H32
		3	500RPP90H32-3H32
		4	500RPP90H32-4H32
60°	0°	2	500RPP60H32-2H32
		3	500RPP60H32-3H32
		4	500RPP60H32-4H32
45°	22.5°	2	500RPP45H32-2H32
		3	500RPP45H32-3H32
		4	500RPP45H32-4H32

Features

- Standard Indexing or Oscillating Motion
- R225 Reducer (Ratios from 5:1 to 60:1)
— 56C Motor Adapter and Coupling
- 1 hp AC Drive Package with Inverter Duty Motor and Inverter Drive (up to 60 cpm)

Optional Accessories

- 1 hp DC Motor
- Varipak DC Motor Control (up to 30 cpm)

Capacity:*

Maximum Mass	180 lbs
Maximum Inertia	3415 lb-in ²

* Note: These values are for speeds of less than 30 rpm, the minimum cam time for rise and rotation, and are for reference only. Each application must be reviewed and approved by CAMCO Engineering.

ROTARY PART HANDLER

Rotary Part Handler | Oscillator Timing Diagram

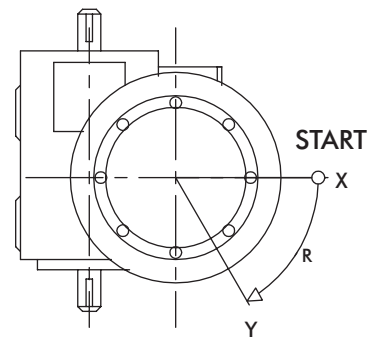
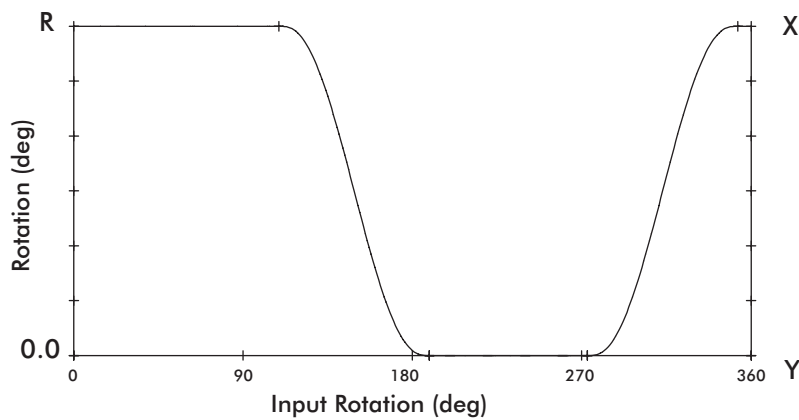
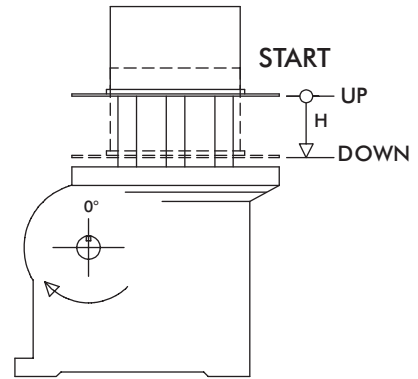
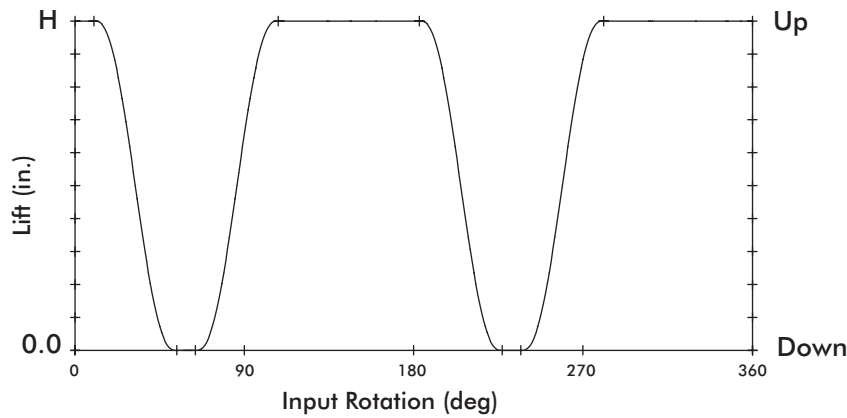

Motion Options

- Standard starting position (home) at time 0 is at maximum rise (up) and at the X rotary position.
- The standard sequence can be mirrored in either the lift, rotary or both:
 - The mirrored lift starts in the zero elevation or down position
 - The mirrored rotary motion starts at Y.
- Custom motion times are also available – consult your Sales Agent for more information.

ROTARY PART HANDLER

Rotary Part Handler | Indexer Timing Diagram

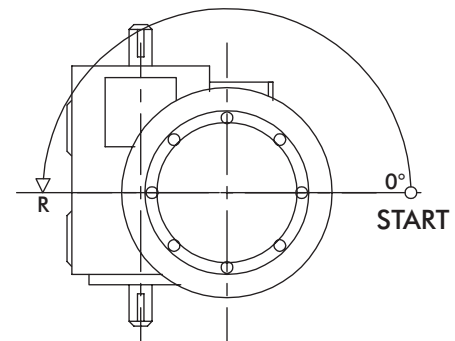
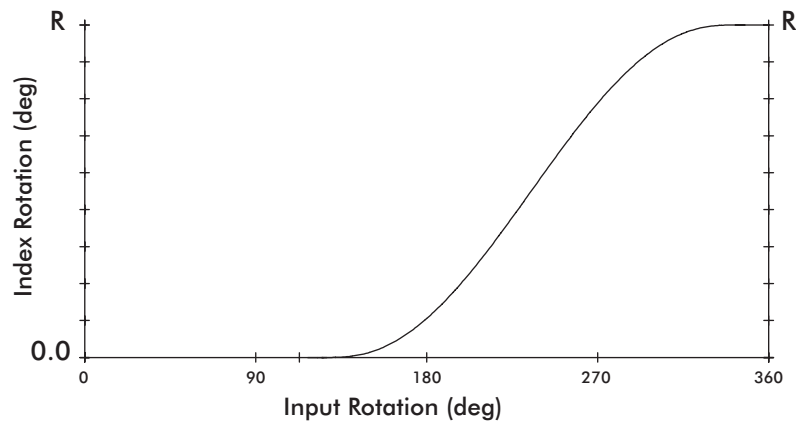
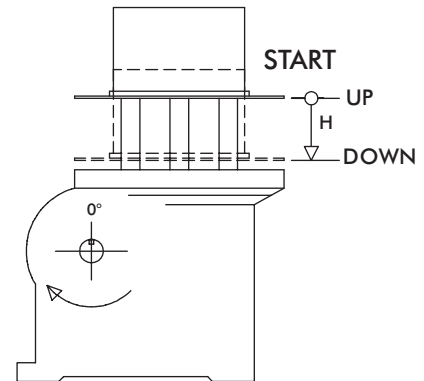
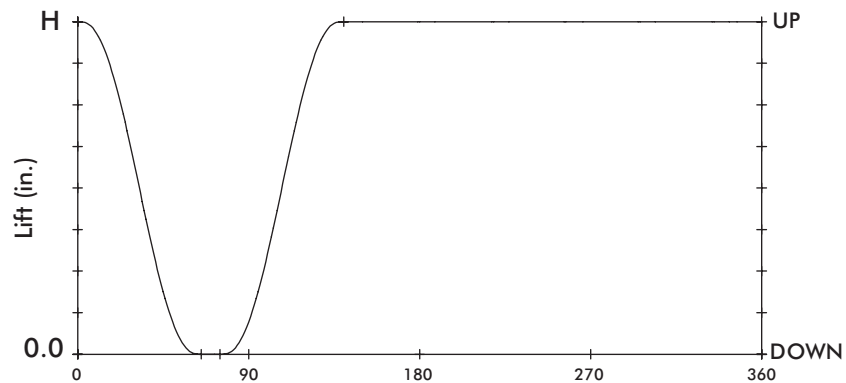

Motion Options

- Standard starting position (home) at time 0 is at maximum rise (up) and at the start of a counter-clockwise index (right-hand cam helix).
- The standard sequence can be mirrored in either the lift, rotary or both:
 - The mirrored lift starts in the zero elevation or down position
 - The mirrored rotary motion is a clockwise index (left-hand helix)
- Custom motion times are also available – consult your Sales Agent for more information.