

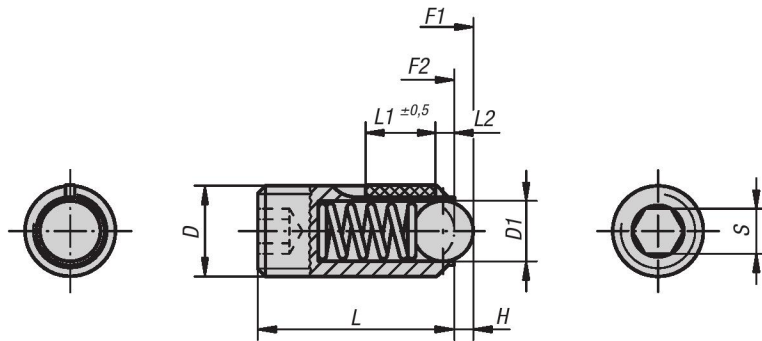

Spring Plungers

LONG-LOK, ball style, hexagon socket, steel

INCH Parts METRIC Parts



L2 = approx. 2x thread pitch

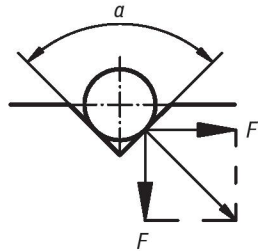

$\alpha = 60^\circ, F' = 1,732 \times F$
 $\alpha = 90^\circ, F' = F$
 $\alpha = 120^\circ, F' = 0,577 \times F$

Material:

Body in steel quality class 5.8.
 Ball in steel.
 Spring in spring steel class D.

LONG-LOK thread system nylon

Type:

Black oxide finish.
 Ball hardened.

Part Number Example:

K0325.AJ

KIPP Spring Plungers, LONG-LOK, ball style, hexagon socket, steel, standard end pressure, inch

Item No.	D	D1	L	L1	H	S	Spring force initial pressure F1 approx. N	Spring force final pressure F2 approx. N	Tightening torque approx. Nm	Loosening torque, after third unscrewing approx. Nm
K0325.AJ	1/4-28	3.5	15	7	1	1/8	9	13	0.44	0.21
K0325.A2	1/4-20	3.5	15	7	1	1/8	9	13	0.44	0.21
K0325.A3	5/16-18	5	18	8	1.5	5/32	15	30	1.10	0.38
K0325.A4	3/8-16	6	23	9	2	3/16	20	35	1.30	0.60
K0325.A5	1/2-13	8	26	10	2.5	7/32	30	55	2.00	1.30
K0325.A6	5/8-11	10	33	14	3.5	5/16	65	125	3.90	3.00



Spring Plungers

LONG-LOK, ball style, hexagon socket, steel

KIPP Spring Plungers, LONG-LOK, ball style, hexagon socket, steel, heavy end pressure, inch

Item No.	D	D1	L	L1	H	S	Spring force initial pressure F1 approx. N	Spring force final pressure F2 approx. N	Tightening torque approx. Nm	Loosening torque, after third unscrewing approx. Nm
K0325.2AJ	1/4-28	3.5	15	7	1	1/8	28	40	0.44	0.21
K0325.2A2	1/4-20	3.5	15	7	1	1/8	28	40	0.44	0.21
K0325.2A3	5/16-18	5	18	8	1.5	5/32	47	73	1.10	0.38
K0325.2A4	3/8-16	6	23	9	2	3/16	66	100	1.30	0.60
K0325.2A5	1/2-13	8	26	10	2.5	7/32	66	120	2.00	1.30
K0325.2A6	5/8-11	10	33	14	3.5	5/16	90	180	3.90	3.00

KIPP Spring Plungers, LONG-LOK, ball style, hexagon socket, steel, standard end pressure, metric

Item No.	D	D1	L	L1	H	S	Spring force initial pressure F1 approx. N	Spring force final pressure F2 approx. N	Tightening torque approx. Nm	Loosening torque, after third unscrewing approx. Nm
K0325.03	M3	1,5	9	4	0,4	1,5	1,5	3	0,10	0,07
K0325.04	M4	2,5	10	5	0,8	2	4	10	0,18	0,12
K0325.05	M5	3	14	6	0,9	2,5	6	11	0,12	0,08
K0325.06	M6	3,5	15	7	1	3	9	13	0,44	0,21
K0325.08	M8	5	18	8	1,5	4	15	30	1,10	0,38
K0325.10	M10	6	23	9	2	5	20	35	1,30	0,60
K0325.12	M12	8	26	10	2,5	6	30	55	2,00	1,30
K0325.16	M16	10	33	14	3,5	8	65	125	3,90	3,00

KIPP Spring Plungers, LONG-LOK, ball style, hexagon socket, steel, heavy end pressure, metric

Item No.	D	D1	L	L1	H	S	Spring force initial pressure F1 approx. N	Spring force final pressure F2 approx. N	Tightening torque approx. Nm	Loosening torque, after third unscrewing approx. Nm
K0325.203	M3	1,5	9	4	0,4	1,5	5	7	0,10	0,07
K0325.204	M4	2,5	10	5	0,8	2	12	22	0,18	0,12
K0325.205	M5	3	14	6	0,9	2,5	19	30	0,12	0,08
K0325.206	M6	3,5	15	7	1	3	28	40	0,44	0,21
K0325.208	M8	5	18	8	1,5	4	47	73	1,10	0,38
K0325.210	M10	6	23	9	2	5	66	100	1,30	0,60
K0325.212	M12	8	26	10	2,5	6	66	120	2,00	1,30
K0325.216	M16	10	33	14	3,5	8	90	180	3,90	3,00