

# GR AND RC MEDIUM DUTY SERIES

## Pneumatic Pivot Units | Product Overview

### GR and RC Series Pneumatic Pivot Units

are used in welding applications or anywhere it is necessary to accurately position tooling. Both the RC and GR series can be mounted in an upright vertical or horizontal position.

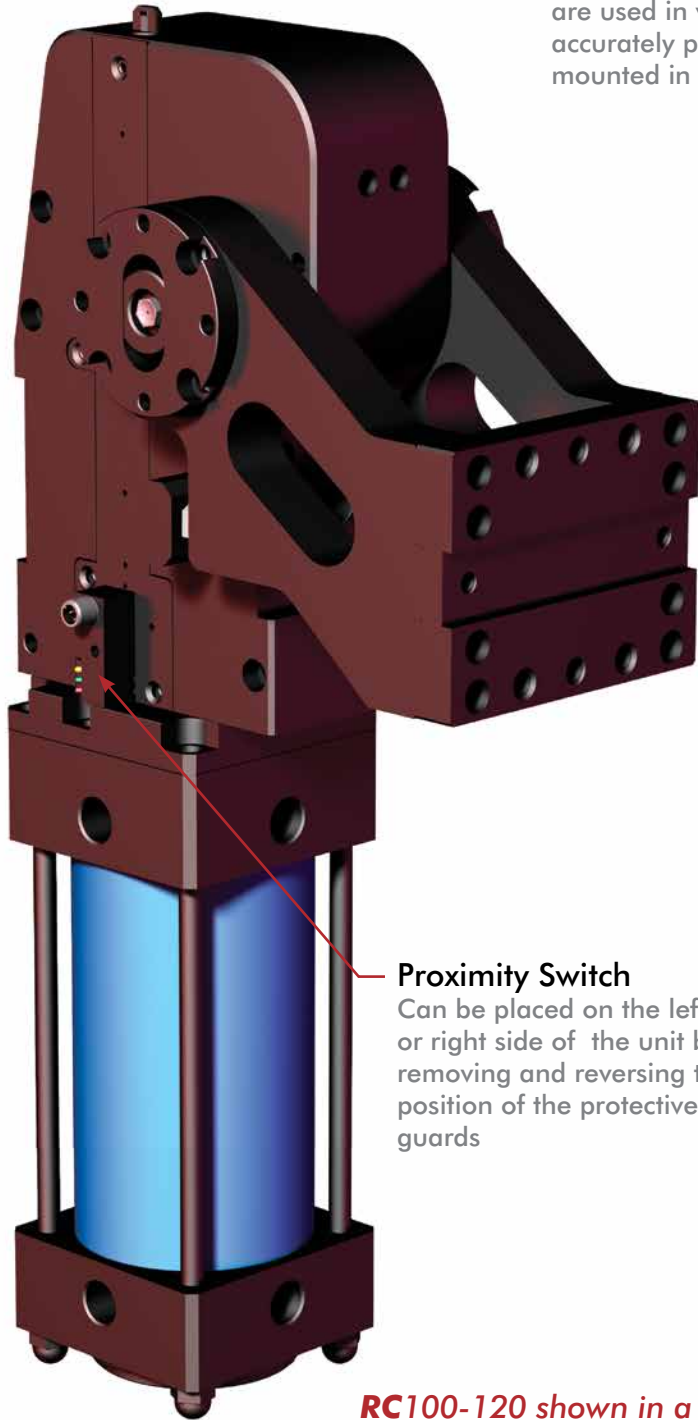

#### Proximity Switch

Can be placed on the left or right side of the unit by removing and reversing the position of the protective guards

**RC100-120 shown in a vertical "V" orientation**

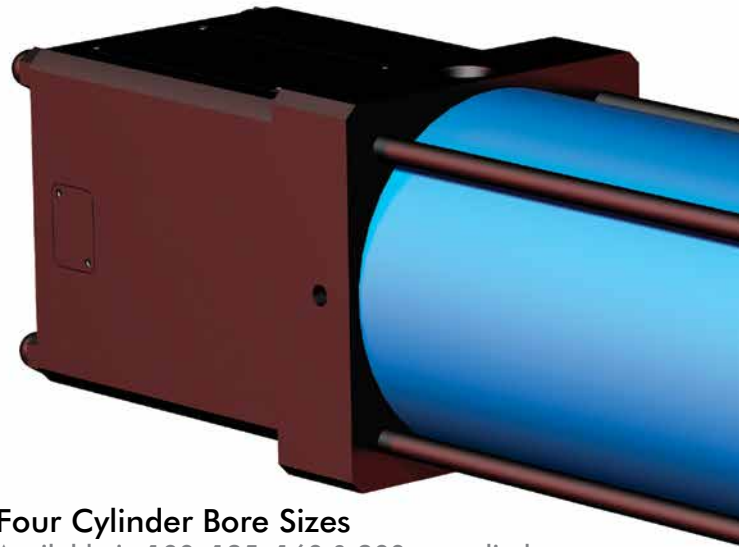

#### Four Cylinder Bore Sizes

Available in 100, 125, 160 & 200mm cylinder bore sizes. Cylinders are offered with NPT or ISO G ports



#### Cut Off Valve (GR Series Only)

Stops movement when air pressure is lost.

# GR AND RC MEDIUM DUTY SERIES

## Pneumatic Pivot Units | Product Overview

### Available in three different arm opening angles

45°, 90° and 120° arm opening angles are available in both the horizontal and vertical mount orientation. Both mounting orientations can also be ordered with an inverted mounting bracket.

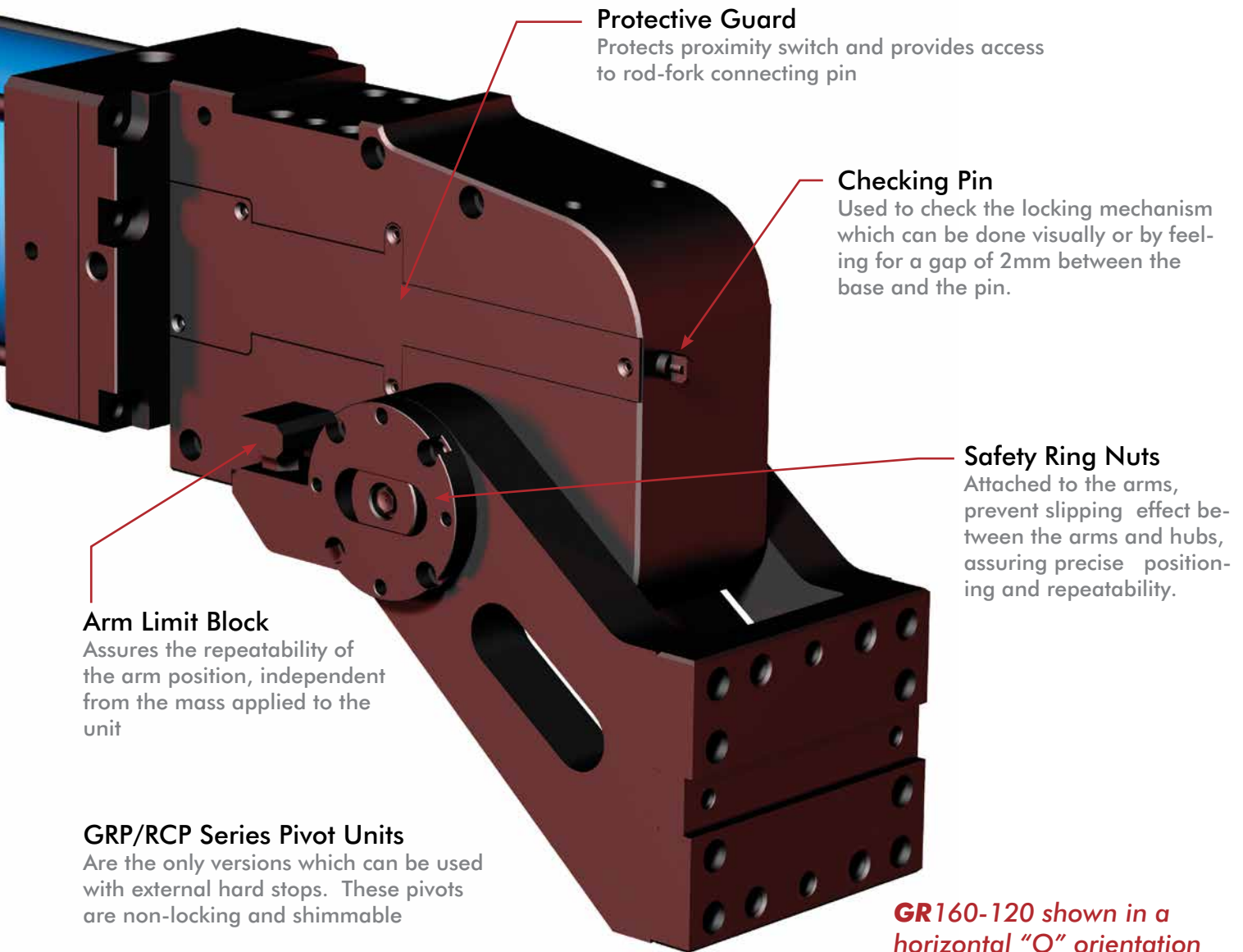

# GR AND RC MEDIUM DUTY SERIES

Pneumatic Pivot Units | Ordering Information

**GR**

**160**

**120**

**V**

## PNEUMATIC PIVOT MODEL

**GR** = GR SERIES PIVOT UNITS  
(HYDRAULIC MOTION CONTROL  
WITH BRAKING FEATURE)

**\*GRP** = GR SERIES PIVOT UNITS  
**NON LOCKING VERSION**  
(HYDRAULIC MOTION CONTROL  
WITH BRAKING FEATURE)

**RC** = RC SERIES PIVOT UNITS  
(HYDRAULIC MOTION CONTROL  
WITHOUT BRAKING FEATURE)

**\*RCP** = RC SERIES PIVOT UNITS  
**NON LOCKING VERSION**  
(HYDRAULIC MOTION CONTROL  
WITHOUT BRAKING FEATURE)

## CYLINDER OPTIONS

**100** = 100MM BORE CYLINDER

**125** = 125MM BORE CYLINDER

**160** = 160MM BORE CYLINDER

**200** = 200MM BORE CYLINDER

## OPENING ANGLE

**45** = 45°

**90** = 90°

**120** = 120°

## ORIENTATION

**O** = HORIZONTAL

**V** = VERTICAL

**O/LS** = INVERTED HORIZONTAL

**V/LS** = INVERTED VERTICAL

**\*ONLY RCP AND GRP PIVOT UNITS  
CAN BE USED WITH EXTERNAL HARD  
STOPS AND SHIMMING**

# GR AND RC MEDIUM DUTY SERIES

Pneumatic Pivot Units | Ordering Information

**PX**

**0**

**N**

**X**

**CYLINDER POSITION**  
(SEE BELOW)

- X** = CYLINDER POSITION X
- Y** = CYLINDER POSITION Y
- W** = CYLINDER POSITION W
- Z** = CYLINDER POSITION Z

**PORT TYPE**  
**N** = NPT PORTS  
**G** = G PORT

**PROXIMITY SWITCH TYPE**  
**0** = NO PROXIMITY SWITCH  
**T** = TURCK PROXIMITY SWITCH  
**P** = PEPPERL+FUCHS PROXIMITY SWITCH  
**PM** = PEPPERL+FUCHS PROXIMITY SWITCH (WHITE LED)

**PROXIMITY SWITCH LOCATION (SEE BELOW)**  
**P0** = NO PROXIMITY SWITCH  
**PX** = PROXIMITY SWITCH ON THE X SIDE  
**PY** = PROXIMITY SWITCH ON THE Y SIDE

## GR & RC Series Optional Cylinder Position (See page 9 for port sizes and locations)

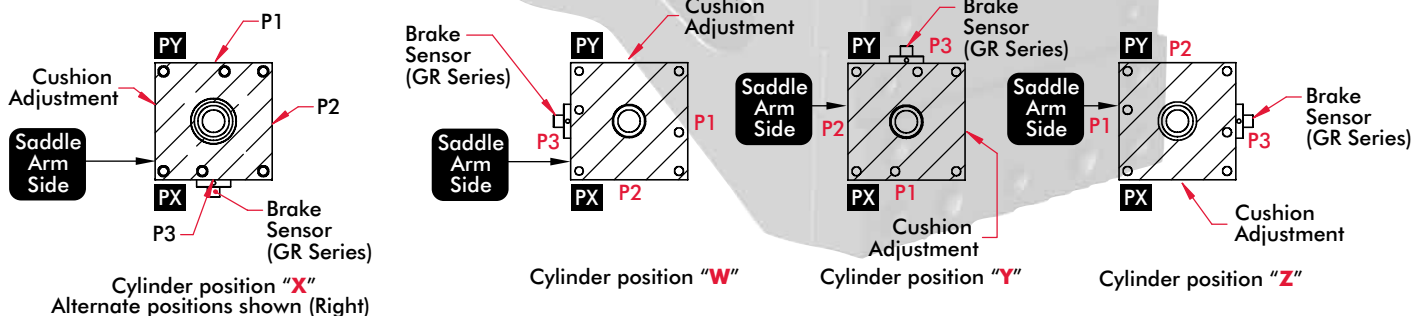

# GR AND RC MEDIUM DUTY SERIES

## Pneumatic Pivot Units | Dimensions

### GR-RC 100 Vertical Orientation Pivot Dimensions

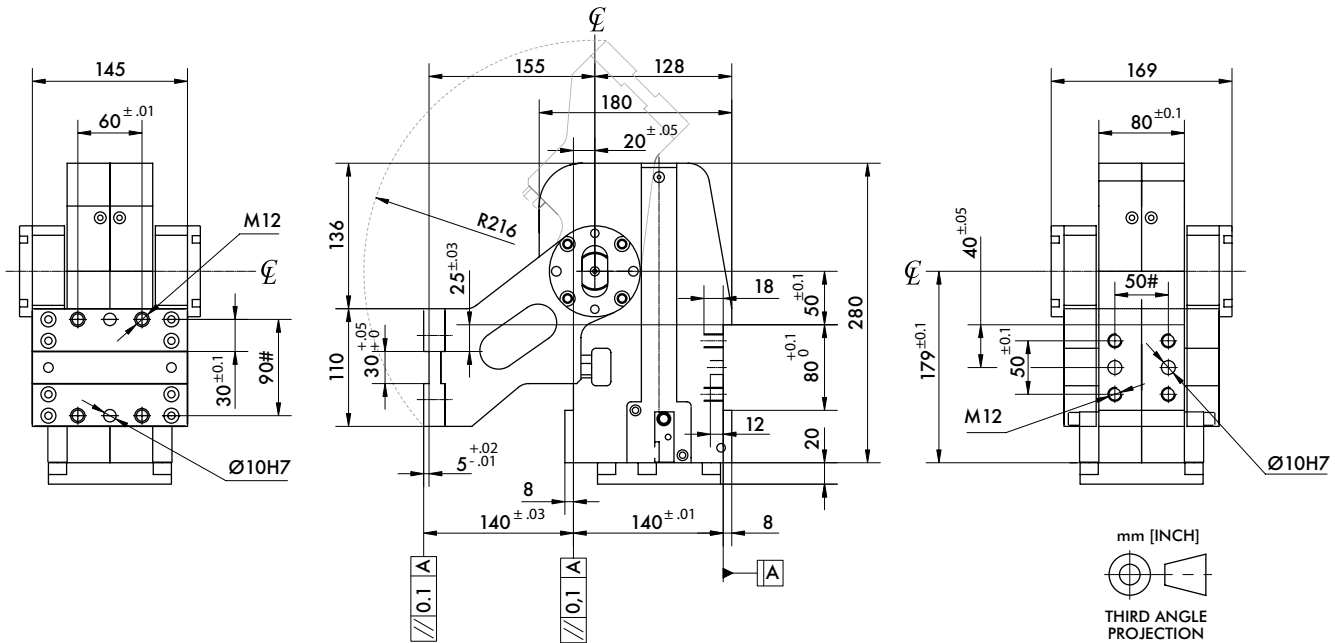

### GR-RC 100 Horizontal Orientation Pivot Dimensions

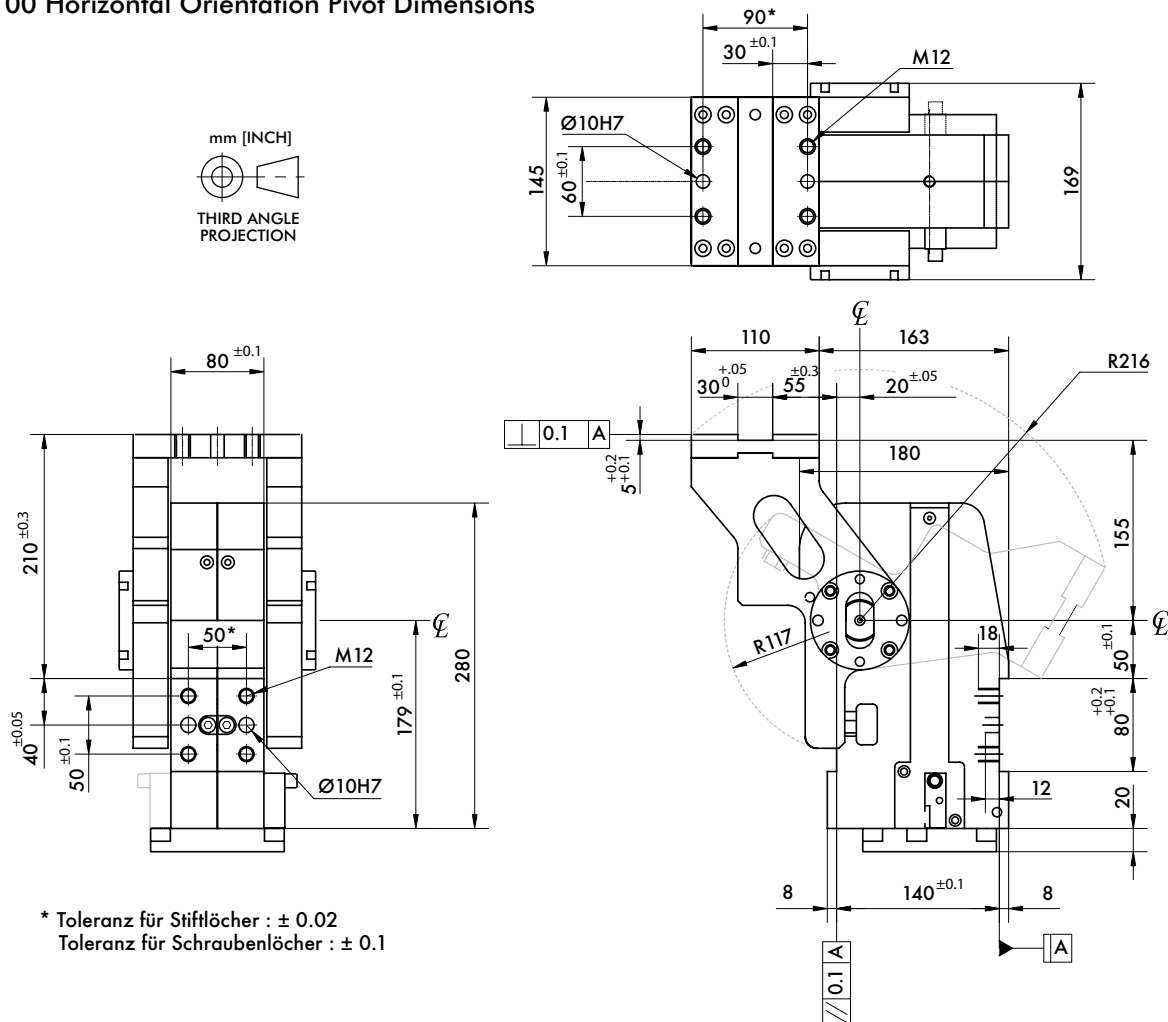

\* Toleranz für Stifflöcher : ± 0.02  
Toleranz für Schraubenlöcher : ± 0.1

# GR AND RC MEDIUM DUTY SERIES

Pneumatic Pivot Units | Dimensions

## GR-RC 125-160-200 Vertical Orientation Pivot Dimensions

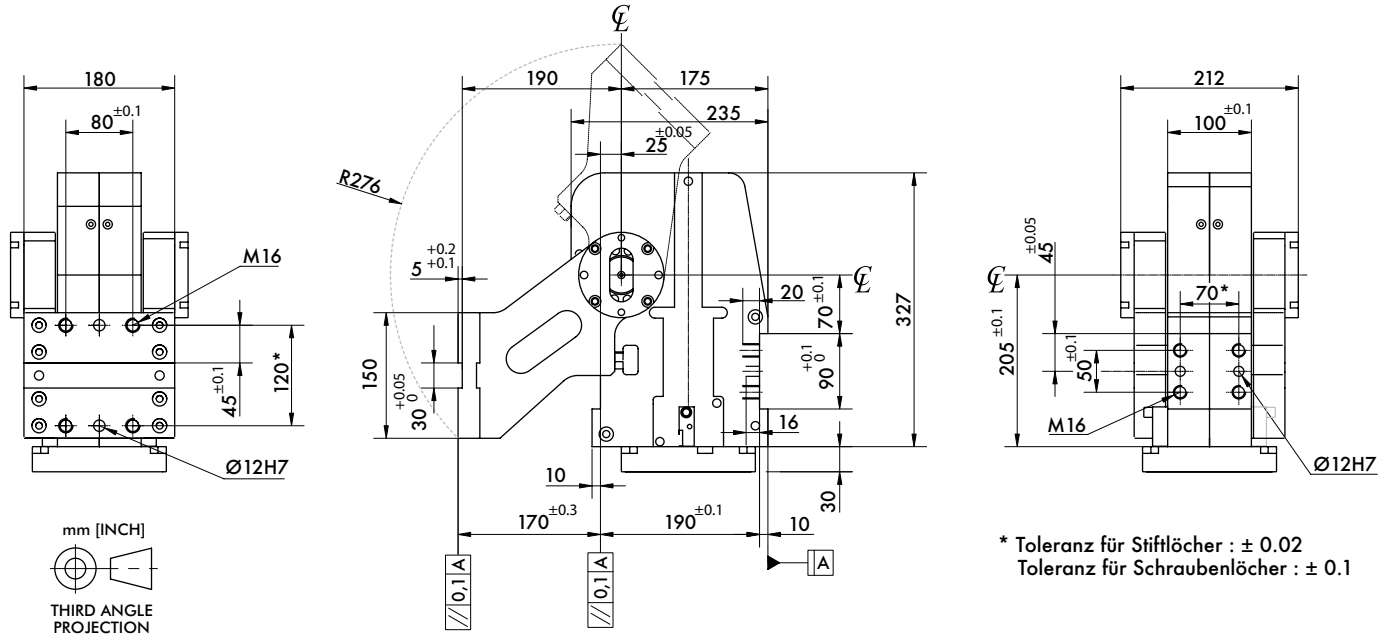

## GR-RC 125-160-200 Horizontal Orientation Pivot Dimensions

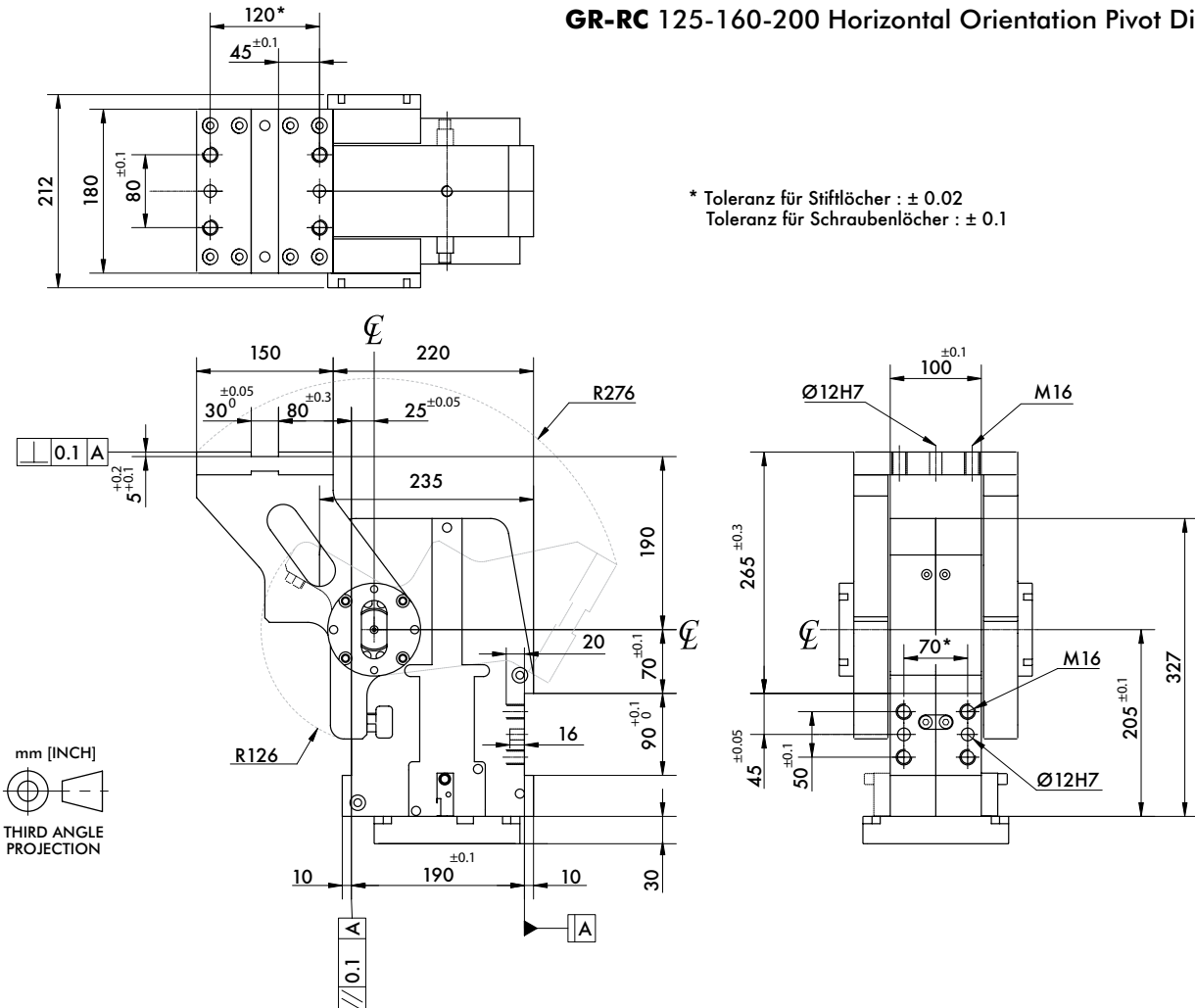

# GR AND RC MEDIUM DUTY SERIES

Pneumatic Pivot Units | Arm Opening Angle and Saddle Movement

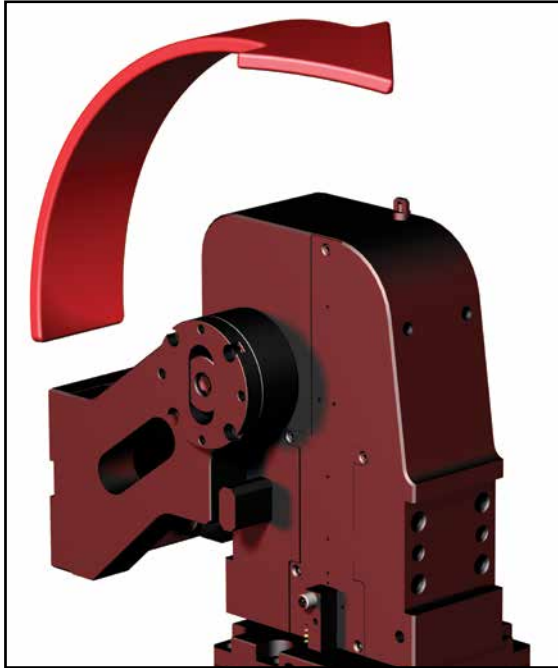

## Vertical Saddle Orientation

Arm opening angles offered:

45° Arm Opening Angle

90° Arm Opening Angle

120° Arm Opening Angle

### Swivel Arm Position

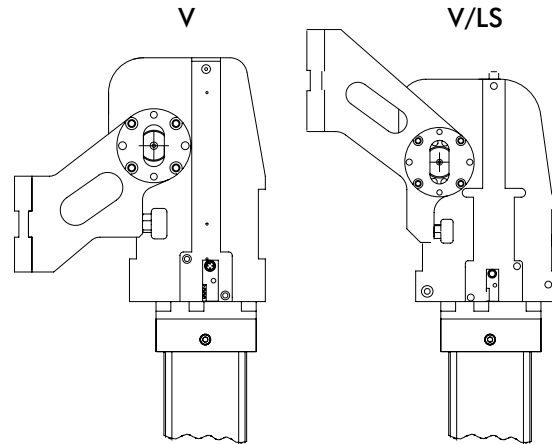

## Horizontal Saddle Orientation

Arm opening angles offered:

45° Arm Opening Angle

90° Arm Opening Angle

120° Arm Opening Angle

### Swivel Arm Position

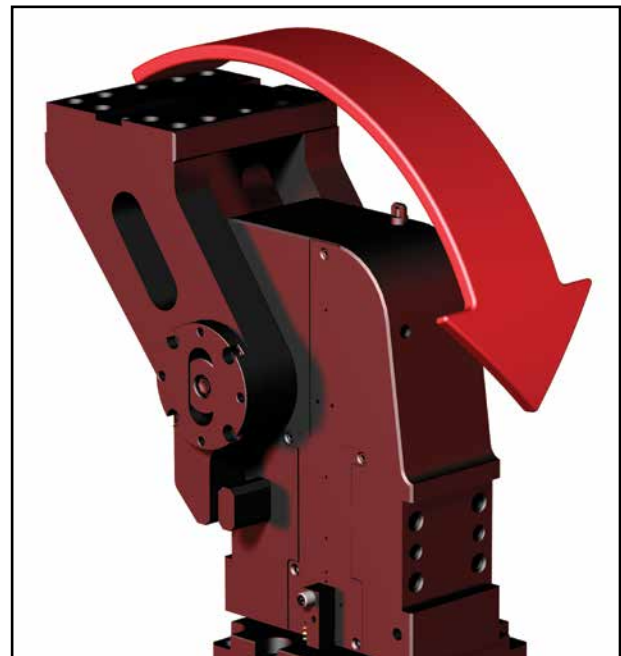
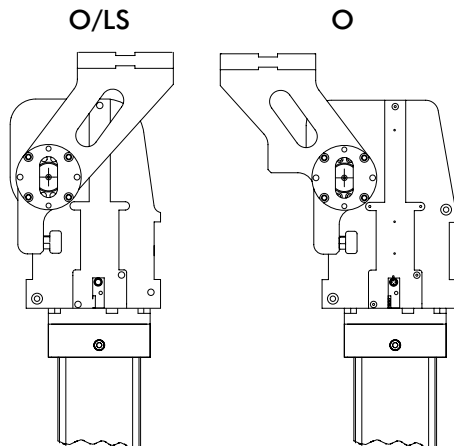



# GR AND RC MEDIUM DUTY SERIES

Pneumatic Pivot Units | Orientation Dimensions

## Type "LS" Vertical Orientation

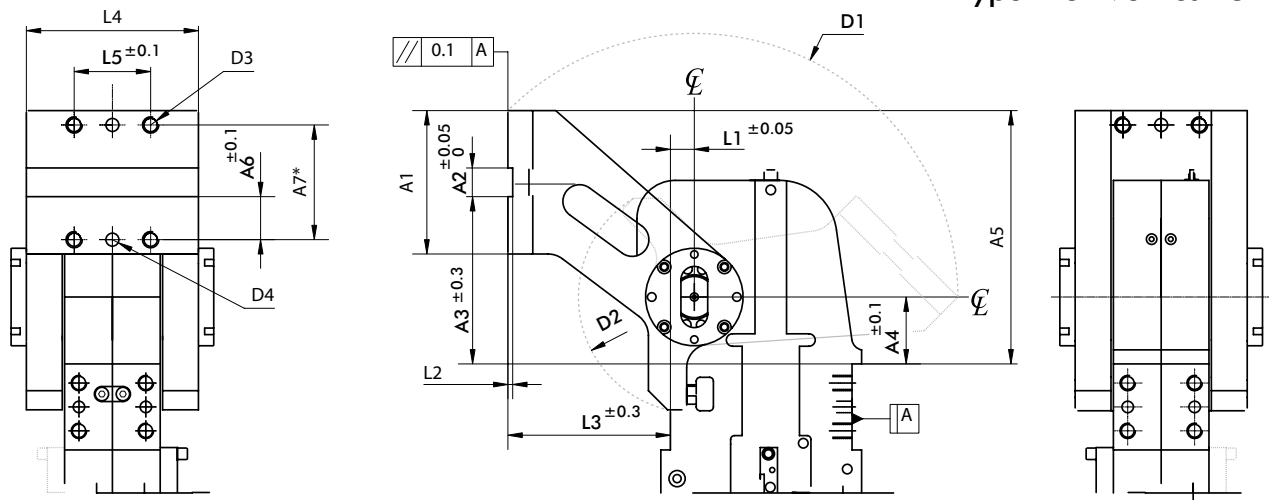

MODEL	A1	A2	A3	A4	A5	A6	A7	L1	L2	L3	L4	L5	D1	D2	D3	D4	Max. opening angle
	mm												~	~	H7		
GR/RC100-...V/LS	110	30	125	50	195	30	90	20	5	140	145	60	216	117	M12	Ø10	120°
GR/RC125-...V/LS																	
GR/RC160-...V/LS	150	30	175	70	265	45	120	25	5	170	180	80	276	126	M16	Ø12	
GR/RC200-...V/LS																	

## Type "LS" Horizontal Orientation

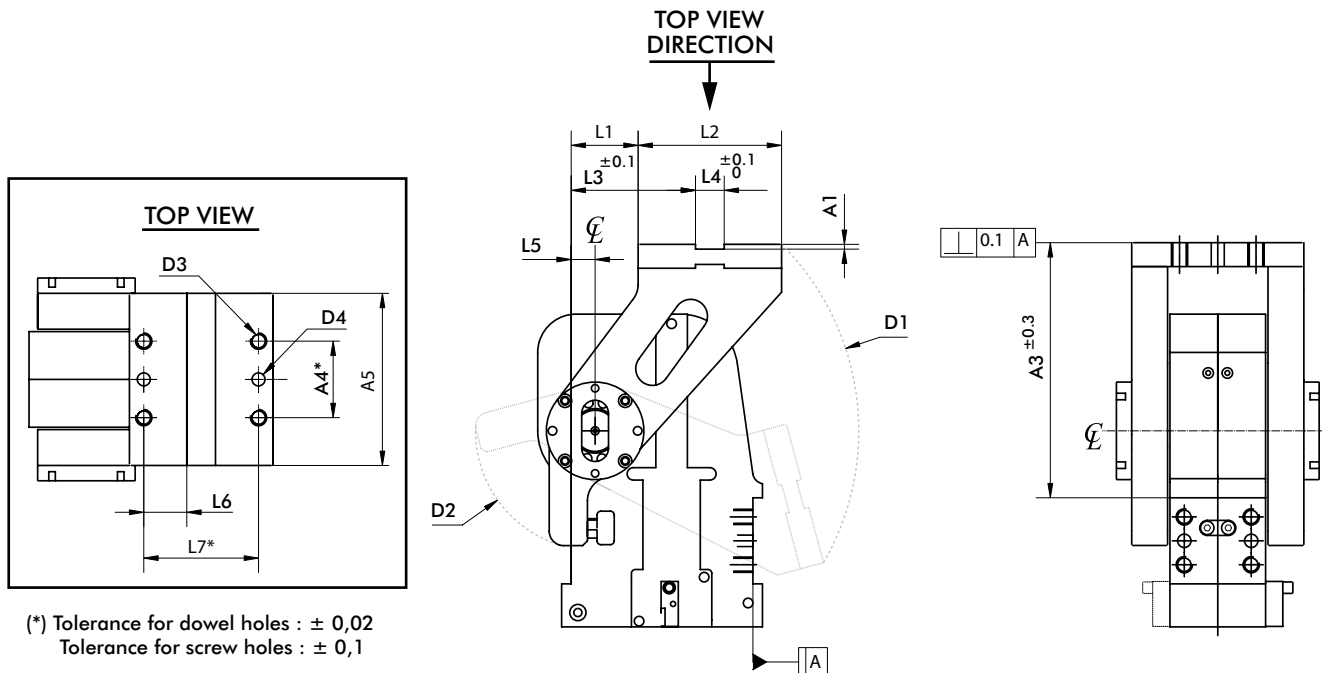

(\*) Tolerance for dowel holes : ± 0,02  
Tolerance for screw holes : ± 0,1

MODEL	A1	A2	A3	A4	A5	L1	L2	L3	L4	L5	L6	L7	D1	D2	D3	D4	Max. opening angle
	mm												~	~	H7		
GR/RC100-...O/LS	5	50	210	60	145	55	110	95	30	20	30	90	216	117	M12	Ø10	90°
GR/RC125-...O/LS																	80°
GR/RC160-...O/LS	5	70	265	80	180	70	150	130	30	25	45	120	276	126	M16	Ø12	
GR/RC200-...O/LS																	



# GR AND RC MEDIUM DUTY SERIES

## Pneumatic Pivot Units | Cylinder Dimensions and Technical Specifications

### GR Series Cylinder Dimensions

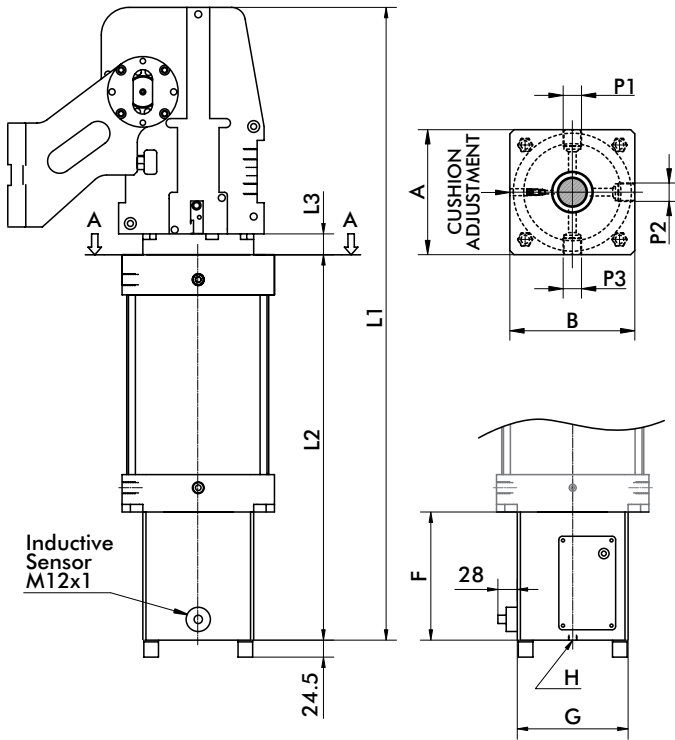

GR MODEL	L1	L2	L3	A - B	P3	P1 - P2	Weight
	mm						
GR100-45°	683.5	383.5				1/2" G	36 kg [80 lb]
GR100-90°	728.5	428.5	20	115	1/2" G	or 1/2" NPT	
GR100-120°	758.0	458.0					
GR125-45°	818.0	466.0				1/2" G	80 kg [176 lb]
GR125-90°	867.0	515.0	25	160	1/2" G	or 1/2" NPT	
GR125-120°	895.0	543.0					
GR160-45°	827.0	472.0				3/4" G	95 kg [209 lb]
GR160-90°	876.0	521.0	28	180	3/4" G	or 3/4" NPT	
GR160-120°	804.0	547.0					
GR200-45°	835.0	478.0				3/4" G	103 kg [226 lb]
GR200-90°	884.0	527.0	30	220	3/4" G	or 3/4" NPT	
GR200-120°	912.0	555.0					

NOTE: "P1-P2" DEPENDANT ON ORDERING CODE

GR MODEL	F	G	H
	mm		
GR100	136	115 SQ	1/4"
GR125	185	160 SQ	1/4"
GR160	185	160 SQ	1/4"
GR200	185	160 SQ	1/4"

### RC Series Cylinder Dimensions

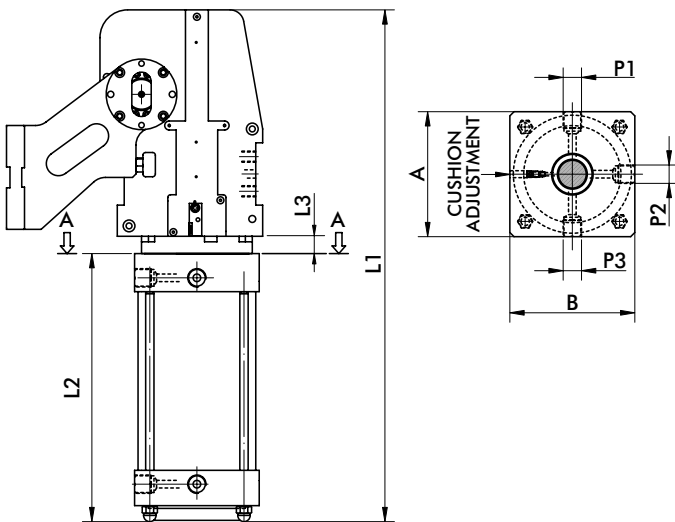

RC MODEL	L1	L2	L3	A - B	P3	P1 - P2	Weight
	mm						
RC100-45°	566.5	266.5				1/2" G	29 kg [64 lb]
RC100-90°	611.5	311.5	20	115	1/2" G	or 1/2" NPT	
RC100-120°	641.0	341.0					
RC125-45°	656.0	304.0				1/2" G	62 kg [137 lb]
RC125-90°	705.0	353.0	25	160	1/2" G	or 1/2" NPT	
RC125-120°	733.0	381.0					
RC160-45°	665.0	310.0				3/4" G	77 kg [170 lb]
RC160-90°	714.0	359.0	28	180	3/4" G	or 3/4" NPT	
RC160-120°	742.0	387.0					
RC200-45°	670.0	313.0				3/4" G	85 kg [187 lb]
RC200-90°	719.0	362.0	30	220	3/4" G	or 3/4" NPT	
RC200-120°	746.5	389.5					

NOTE: "P1-P2" DEPENDANT ON ORDERING CODE

### GR & RC Series Optional Cylinder Orientation

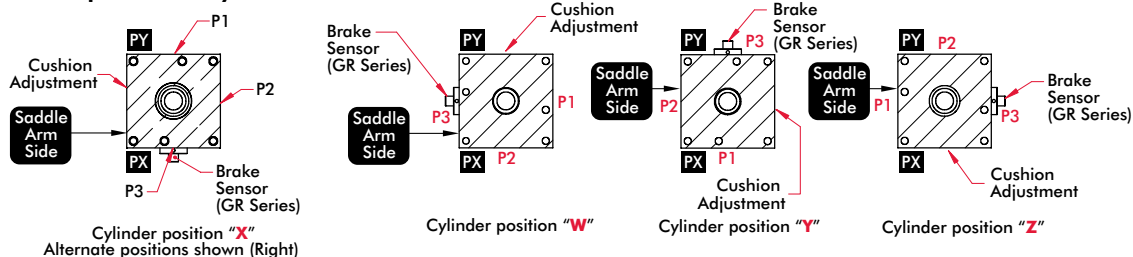



# GR AND RC MEDIUM DUTY SERIES

## Pneumatic Pivot Units | Maximum Torque for Weight

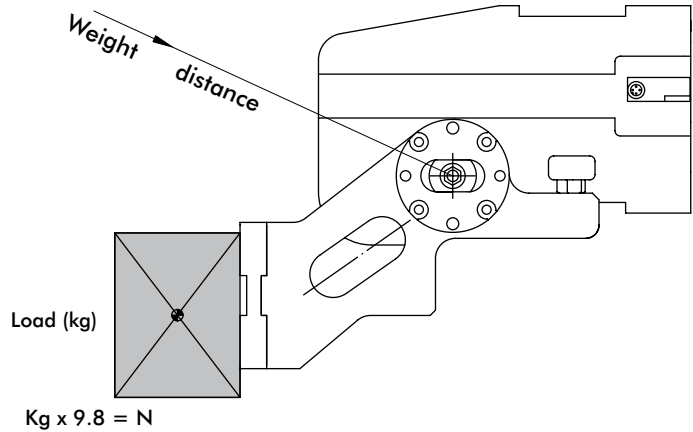
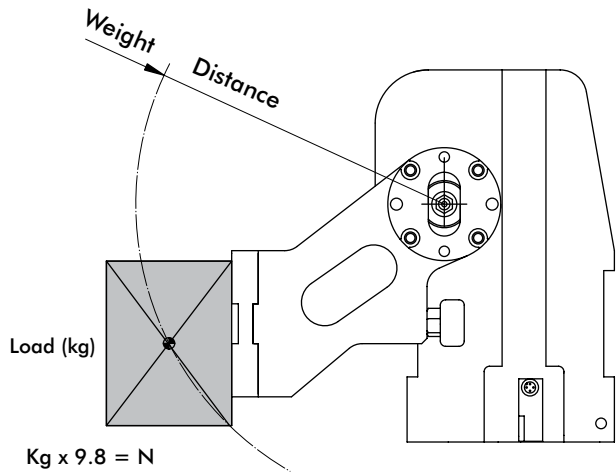

Model	Maximum Torque for Weight - ≤ 90° opening					
	58psi / 4 Bar		72psi / 5 Bar		87psi / 6 Bar	
	lbf*in	N*m	lbf*in	N*m	lbf*in	N*m
GR/RC100	1062	120	1328	150	1682	190
GR/RC125	1563	180	2124	240	2567	290
GR/RC160	2832	320	3629	410	4425	500
GR/RC200	4514	510	5841	660	7081	800

Model	Maximum Torque for Weight - > 90° opening					
	58psi / 4 Bar		72psi / 5 Bar		87psi / 6 Bar	
	lbf*in	N*m	lbf*in	N*m	lbf*in	N*m
GR/RC100	620	70	797	90	1062	120
GR/RC125	1239	140	1593	180	2036	230
GR/RC160	2124	240	2744	310	3540	400
GR/RC200	3629	410	4602	520	5488	620

Model	Maximum Torque with Side Load for Weight					
	58psi / 4 Bar		72psi / 5 Bar		87psi / 6 Bar	
	lbf*in	N*m	lbf*in	N*m	lbf*in	N*m
GR/RC100	708	80	708	80	708	80
GR/RC125	1770	200	1770	200	1770	200
GR/RC160	1770	200	1770	200	1770	200
GR/RC200	1770	200	1770	200	1770	200

Center of Gravity to Pivot (distance in Meters [Inches]) X Tooling Weight (N [lb]) = Torque for weight (N\*m [lbf\*in])

Distance from Center of Gravity to pivot is measured parallel to the floor

### Notes

The total torque for the application must be less than the Maximum Torque for a given pressure in the Maximum Torque for Weight charts above. For applications with a total torque greater than the Maximum Torque shown, please see RU Series Pivot Units.

Based on cycle time of 7-8 seconds. Flow controls must be used to provide this cycle time. Cushions must also be adjusted to provide deceleration to the load. Failure to control movement will severely damage unit and cause premature failure.

Use the following graphs to determine the maximum amount of tooling weight that is allowed. The tooling load should be placed as close to the center line of the unit as possible.

# GR AND RC MEDIUM DUTY SERIES

Pneumatic Pivot Units | Maximum Added Tooling Weight Greater than 90°

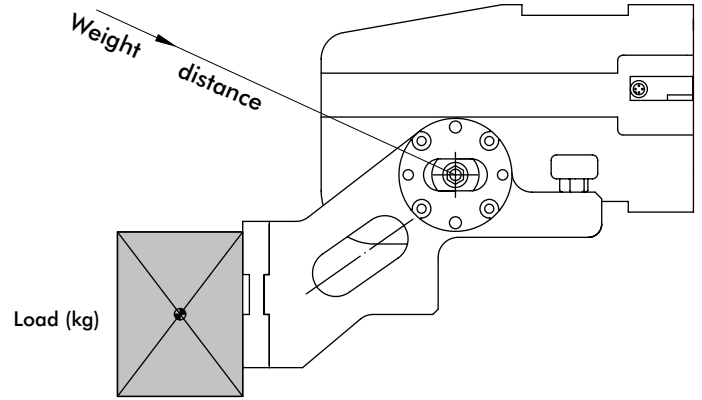
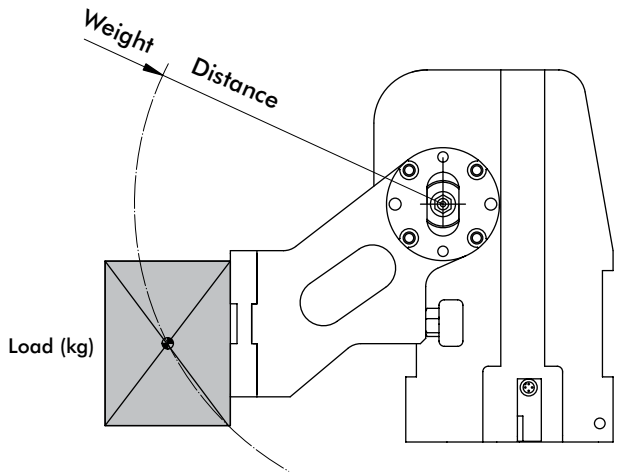

**GR/RC 100**

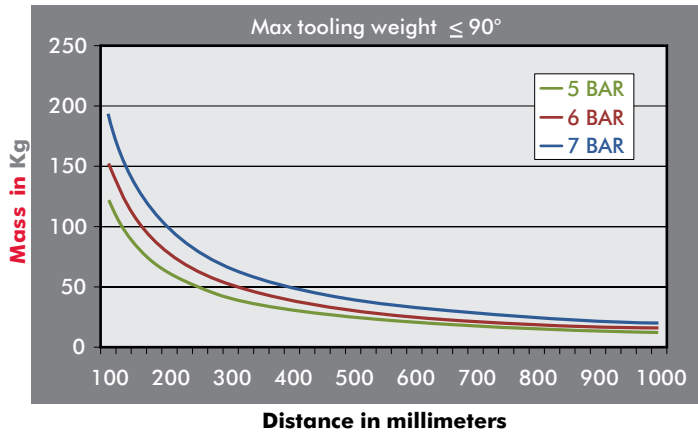

**GR/RC 125**

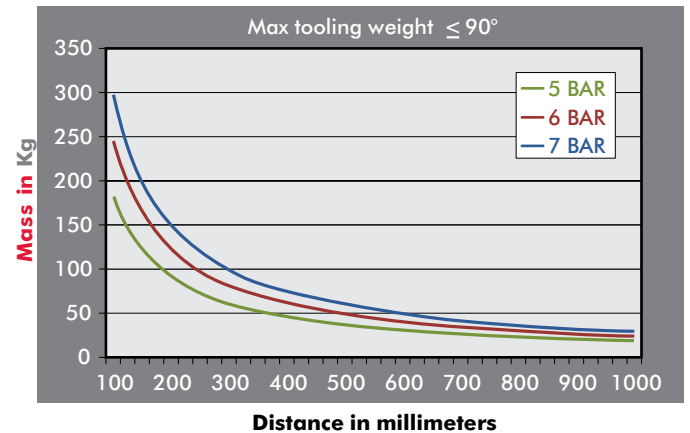

**GR/RC 160**

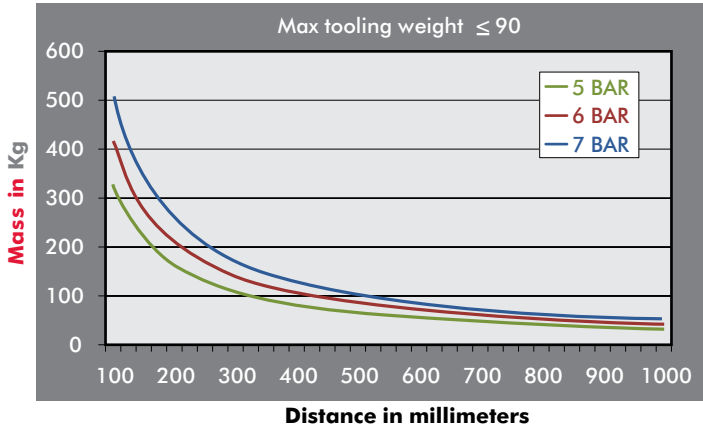

**GR/RC 200**

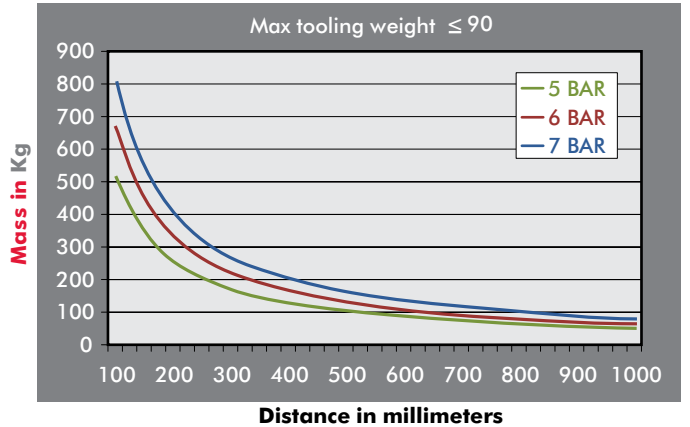

# GR AND RC MEDIUM DUTY SERIES

Pneumatic Pivot Units | Maximum Added Tooling Weight Greater than 90°

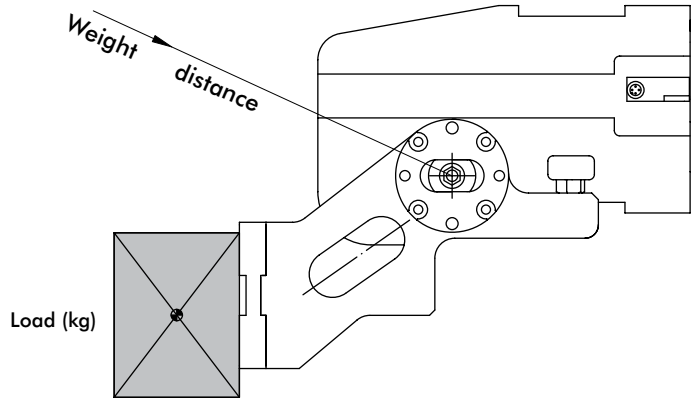
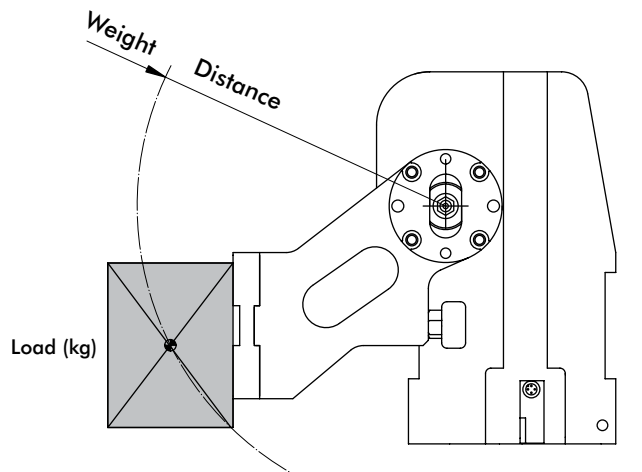

**GR/RC 100**

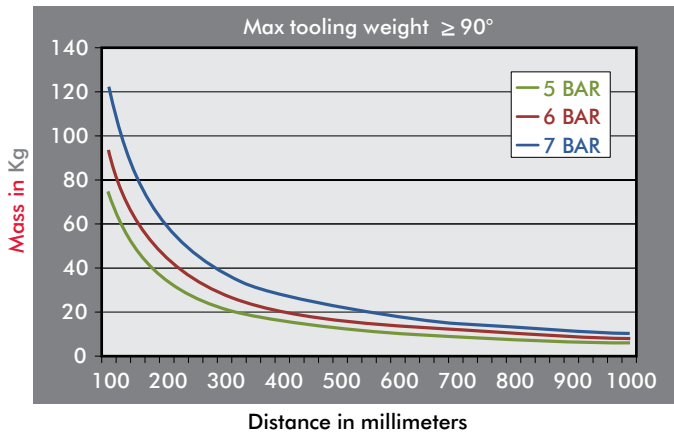

**GR/RC 125**

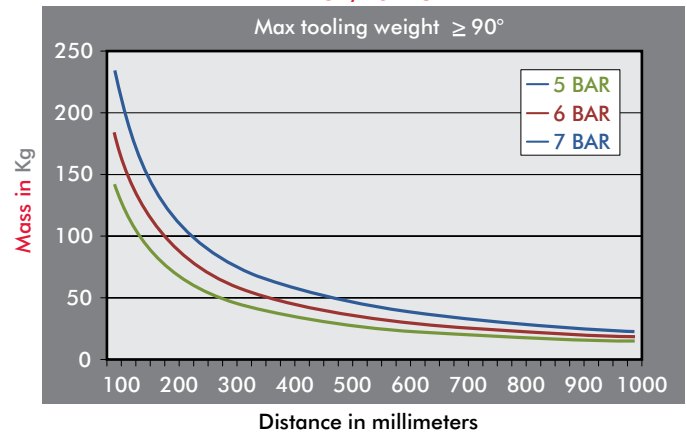

**GR/RC 160**

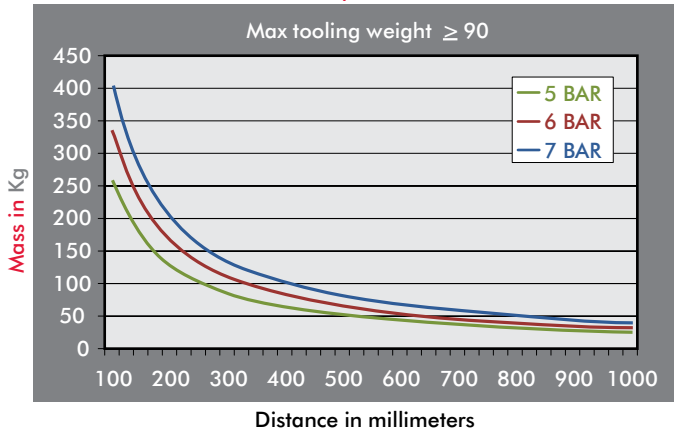

**GR/RC 200**

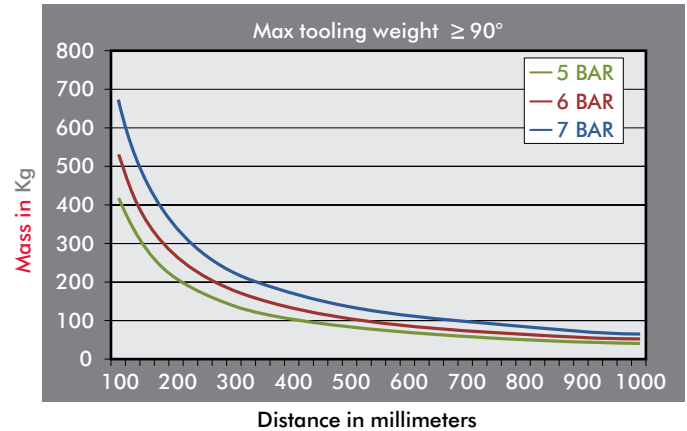

# GR AND RC MEDIUM DUTY SERIES

Pneumatic Pivot Units | Force Charts for Opening Angles

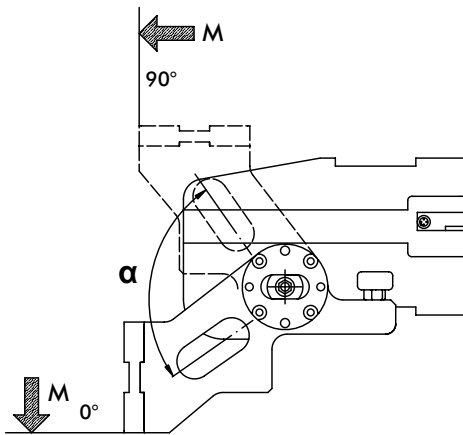

( Values calculated at 1 m from center of rotation )

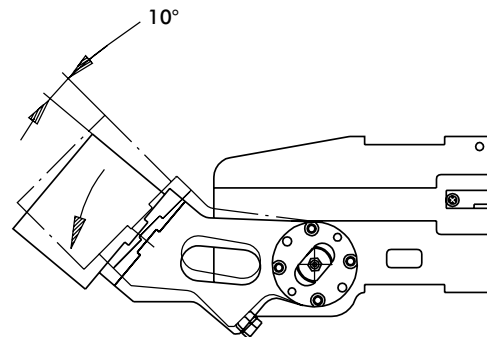

Play of swing arm while closed emergency stop value

**Conditions:**

- Emergency stop in operator
  - Cylinder depressurized
  - Max. load
- Max. play 10°

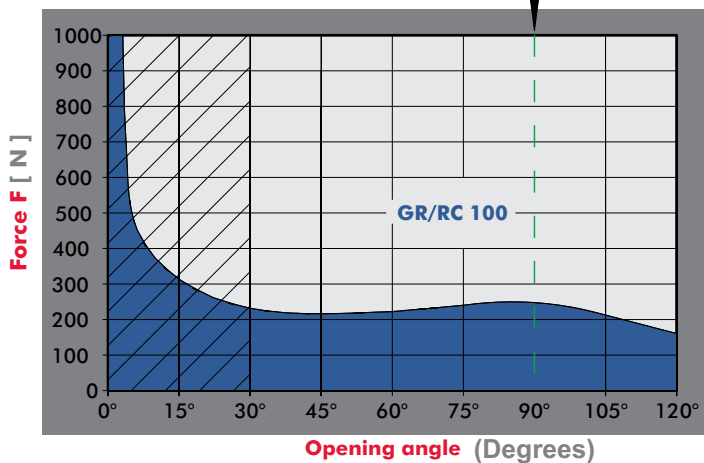

MODEL	TORQUE WITH ARM AT 90°
GR/RC 100	240 Nm
GR/RC 125	370 Nm
GR/RC 160	630 Nm
GR/RC 200	1000 Nm

**NOTE:** Values at 6 bar

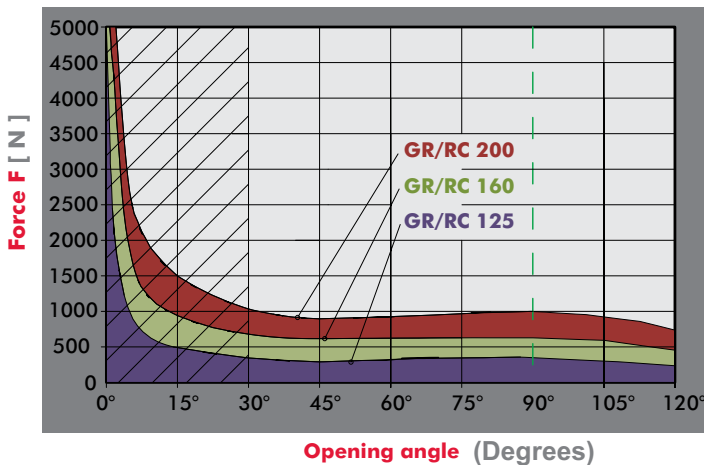

**WARNING:** Make sure that the tilting device runs a complete working cycle and reaches the angle position at 0°. (Any interference in the highlighted angle area may seriously damage both the tooling and the tilting device, as the result of the very high forces developed, as shown in the chart).

**Do not use external stops with GR/RC Series Pivot Units!**