

82D40-2/82D63-5 SERIES

Pneumatic Power Clamps | Features and Benefits | Technical Information

Features:

- Compact, enclosed design
- Narrow design
- Adapts to various holding arm variants
- High accuracy of positioning due to internal holding arm stopper
- 2 lateral and 1 front mounting areas
- Low weight (aluminium body)
- Integrated inductive sensing module with LED display
- Cylinder diameter 40 mm or 64 mm

Application:

- Clamping, holding, gripping and positioning of metal sheets and other parts, mainly in jigs and handling systems.

Key areas of application:

- Automotive manufacturing, sheet processing industry, jig and general mechanical engineering.



- Automation power clamps, enclosed and narrow design for 2 clamping arms

Models: **82D40-2...**
82D63-5...

82D40-223C900
Base model with
2 U-clamping arms

Technical Information

| Model | Clamping position | Standard opening angle | Driveshaft | Max. holding torque Nm [lb ft] | Clamping torque at 5 bar Nm [lb ft] | Cylinder Ø mm [in] | Air consumption per double stroke at 5 bar dm ³ [ft ³] | Weight ~ kg [lbs] |
|-----------------------|-------------------|------------------------|---|--------------------------------------|--|-----------------------|--|----------------------------|
| 82D40-223C900B | vertical | 180° | lateral, both sides U-type clamping arms | 55 [40] | 55 [40] | 40 [1.57] | 1,2 [0.04] | 2,5 [5.50] |
| 82D63-523C900B | vertical | 180° | lateral, both sides U-type clamping arms | 120 [88] | 120 [88] | 63 [2.48] | 3,8 [0.13] | 4,5 [9.90] |

| Model | B1 | B2 | B3 | L1 | SW | G |
|-----------------------|----|----|----|------|----|-----|
| 82D40-223C900B | 30 | 30 | 60 | 12,5 | 11 | 1/4 |
| 82D63-523C900B | 47 | 47 | 94 | 21 | 19 | 1/4 |

How To Order

82D63-5 23 C9 0 0 B

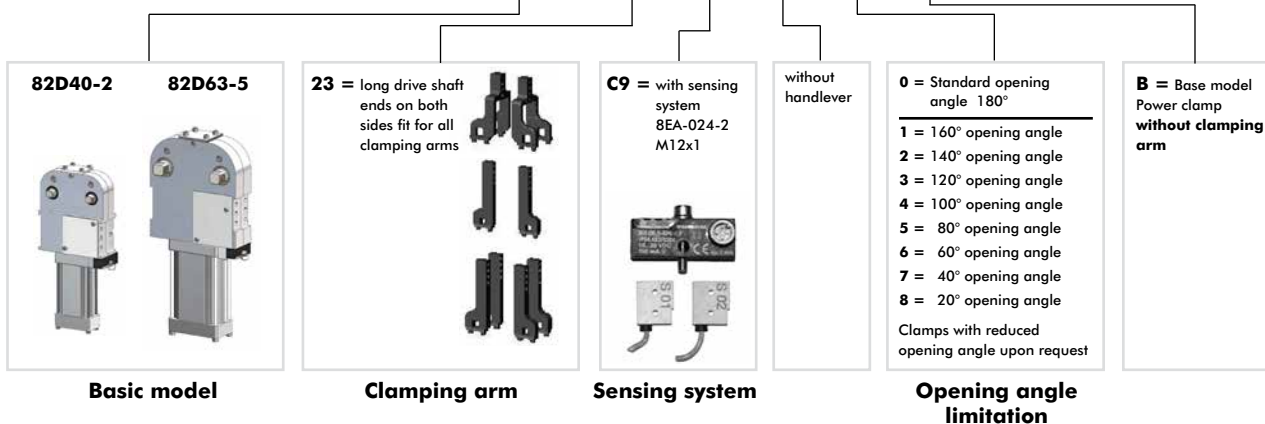

82D40-2/82D63-5 SERIES

Pneumatic Power Clamps | Dimensions

82D40-223C900B

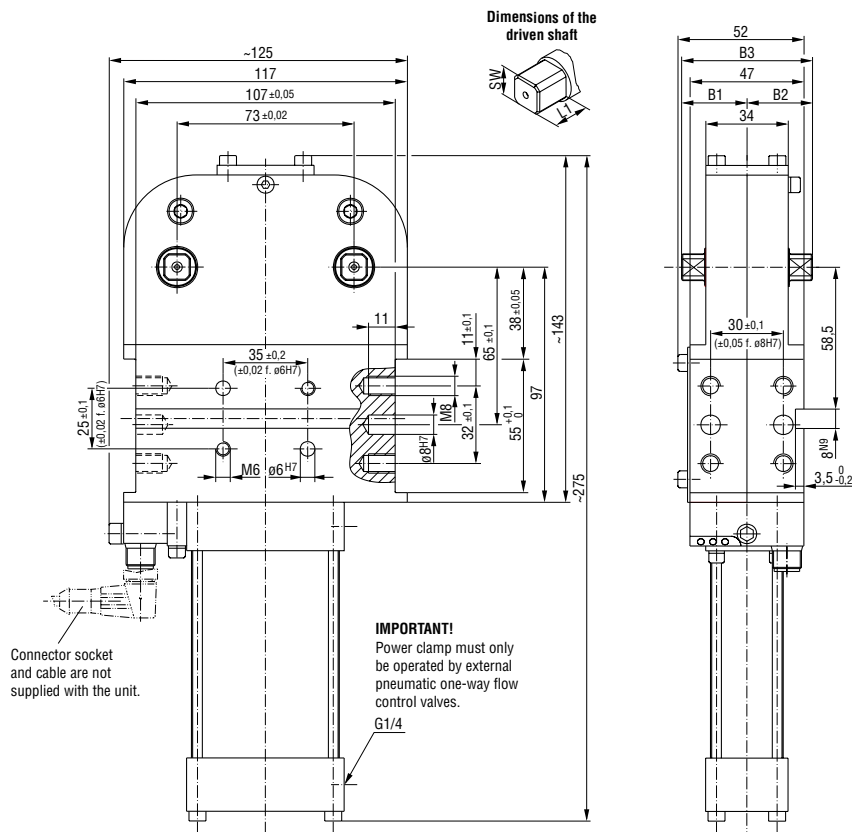

Safety notice:
The load on the clamping arms must always point towards the clamping direction. Single load of one arm is prohibited

Medium: air, max. 6 bar, operation with oil-free air is permissible

82D63-523C900B

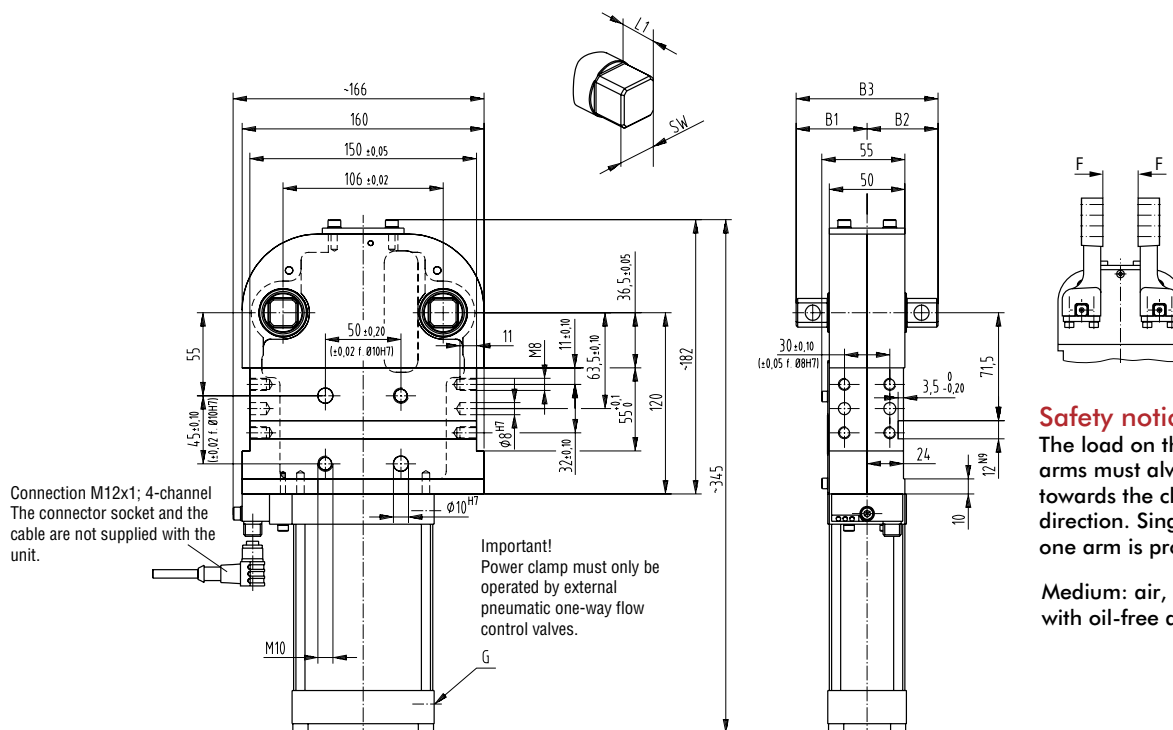

Safety notice:
The load on the clamping arms must always point towards the clamping direction. Single load of one arm is prohibited

Medium: air, max. 6 bar, operation with oil-free air is permissible

U-ARMS CENTER (STEEL)

Pneumatic Power Clamps | Dimensions | Technical Specifications

- Clamping arm variants for **82D40-2**

Clamping arm variant U-type central clamping arm



Base model with 2 U-type clamping arms, small gap between clamping arms

U-type central clamping arm | Technical Information

| Model | Order no. for U-type clamping arm set (1 clamping arm) | Clamping position | Standard opening angle | B2 | B4 | B9 | B10 | B11 | B12 | B26 | | | |
|----------------|--|-------------------|------------------------|-----|------|----|-------|------|------|-----|----|----|------|
| 82D40-223C900B | 8JG-065-2-01 | vertical | 180° | 105 | 45,3 | 6 | ±0,02 | +0,1 | ±0,2 | 20 | 79 | 20 | 68,2 |

| Model | Order no. for U-type clamping arm set (1 clamping arm) | B31 | D2 | D3 | L4 | L10 | L10a | L20 | L21 | | | | | |
|----------------|--|-------|---------|----|------|-----|------|-----|-----|----|----|------|----|----|
| 82D40-223C900B | 8JG-065-2-01 | ±0,02 | H7 ø | ø | ±1,1 | ~ | 73 | 6 | 7 | 20 | 12 | 11,3 | 33 | 73 |

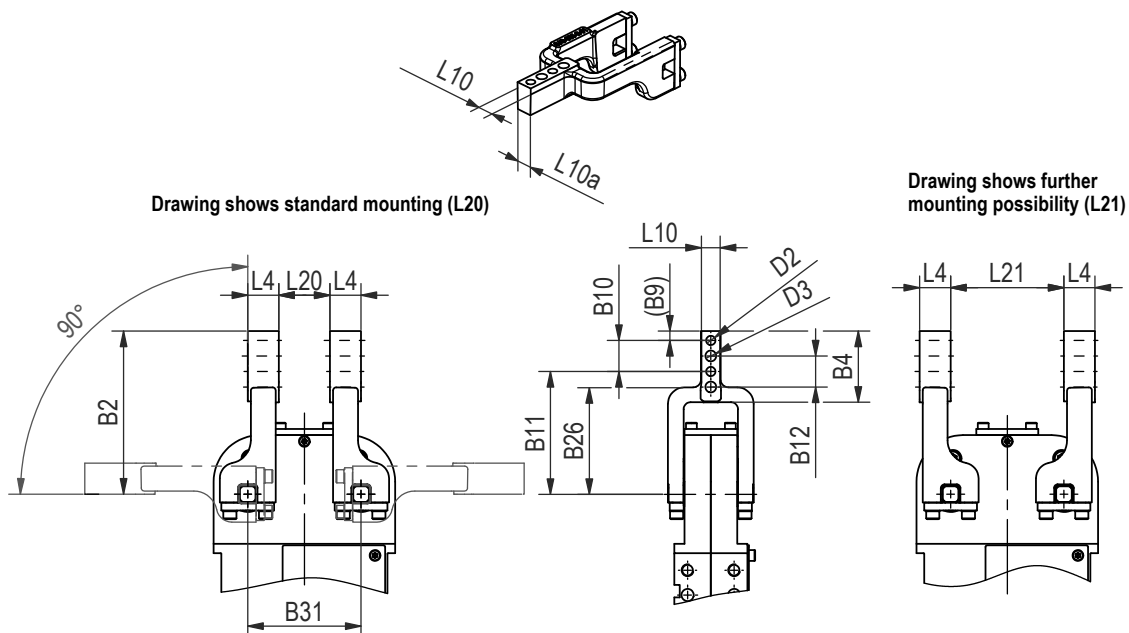

U-ARMS CENTER (STEEL)

Pneumatic Power Clamps | Dimensions | Technical Specifications

- Clamping arm variants for **82D63-5**

Clamping arm variant U-type central clamping arm



Base model with 2 U-type clamping arms, small gap between clamping arms

U-type central clamping arms | Technical Information

| Model | Order no. for U-type clamping arm set (1 clamping arm) | Clamping position | Standard opening angle | B2 | B4 | B9 | B10 | B11 | B12 | B26 |
|----------------|--|-------------------|------------------------|-----|------|----|-------|------|------|-----|
| 82D63-523C900B | 8JG-069-1-01 | vertical | 180° | 144 | 64,3 | 9 | ±0,02 | +0,1 | ±0,2 | 95 |

| Model | Order no. for U-type clamping arm set (1 clamping arm) | B31 | D2 | D3 | L4 | L5 | L10 | L10a | L20 | L21 |
|----------------|--|-------|---------|----|----|----|------|------|-----|-----|
| 82D63-523C900B | 8JG-069-1-01 | ±0,02 | H7 ∅ | ∅ | 28 | 15 | ±1,2 | ~ | 20 | 136 |

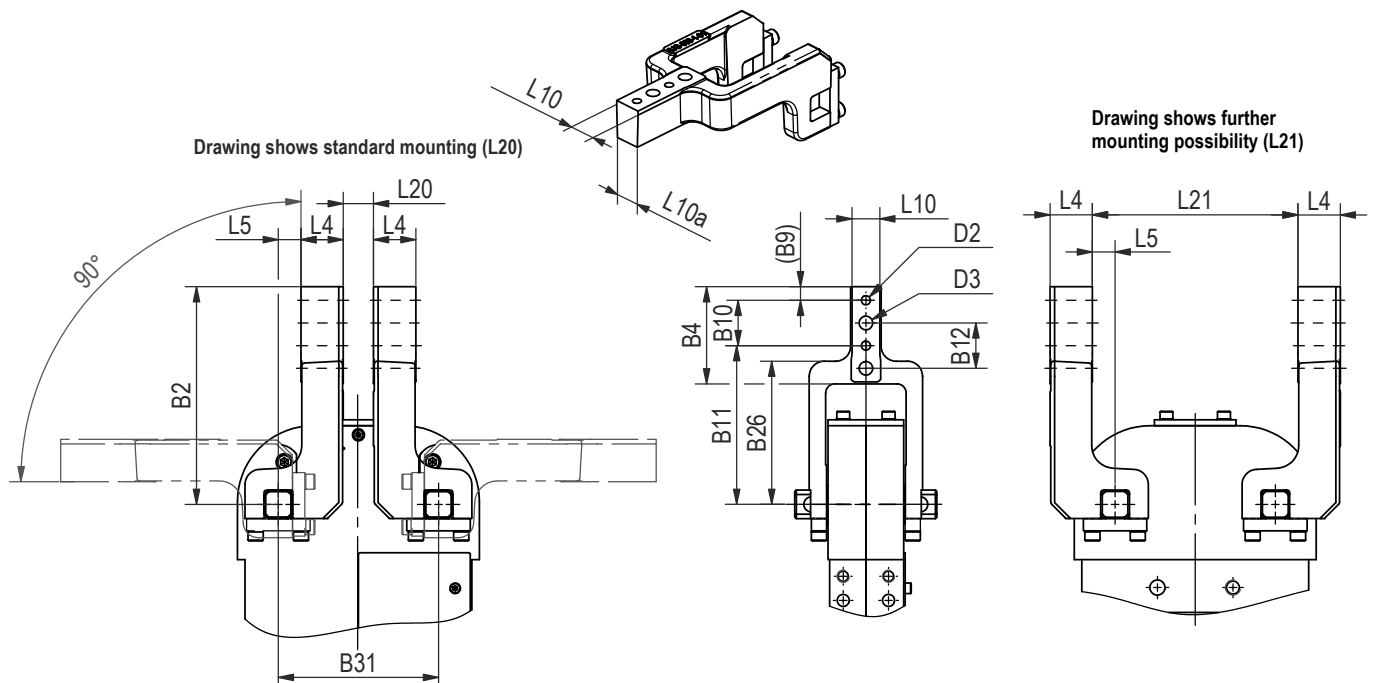

LATERAL (SIDE) ARMS

Pneumatic Power Clamps | Dimensions | Technical Specifications

- Clamping arm variants for **82D40-2**

Clamping arm variant

- Lateral clamping arm left
- Lateral clamping arm right
- Lateral clamping arm both sides



Base model with 4 lateral clamping arms, large gap between clamping arms

Lateral clamping arm | Technical Information

| Model | Clamping arm variant | Order no. for 1 set of lateral clamping arms (1 clamping arm) | Clamping position | Standard opening angle | B2 | B4 | B9 | B10 | B11 | B12 |
|----------------|--|---|-------------------|------------------------|-----|----|----|-------|------|------|
| 82D40-223C900B | lateral, left lateral, right lateral, both sides | 8JG-066-1-01 | vertical | 180° | 105 | 45 | 6 | ±0,02 | +0,1 | ±0,2 |

| Model | Clamping arm variant | Order no. for 1 set of lateral clamping arms (1 clamping arm) | B31 | D2 | D3 | L4 | L10 | L20 | L21 |
|----------------|--|---|-------|---------|----|----|------|-----|-----|
| 82D40-223C900B | lateral, left lateral, right lateral, both sides | 8JG-066-1-01 | ±0,02 | H7 ∅ | ∅ | | -0,1 | | |
| 82D40-223C900B | lateral, left lateral, right lateral, both sides | 8JG-066-1-01 | 73 | 6 | 7 | 20 | 12 | 33 | 73 |

Drawing shows standard mounting (L20) with four lateral clamp arms

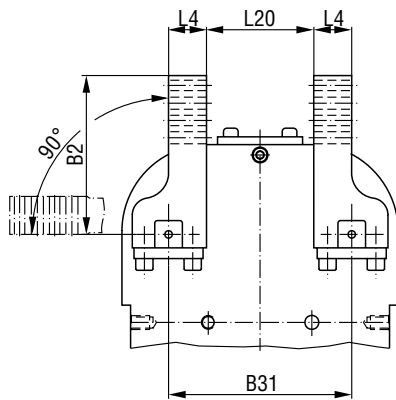

Drawing shows further mounting possibility (L21)

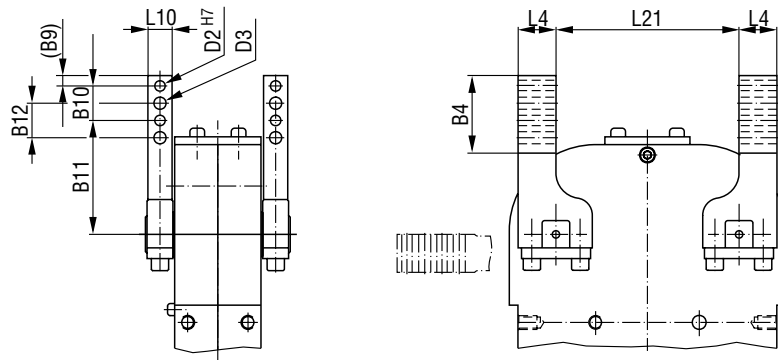

LATERAL (SIDE) ARMS

Pneumatic Power Clamps | Dimensions | Technical Specifications

• Clamping arm variants for **82D63-5**

Clamping arm variant

- Lateral clamping arm left
- Lateral clamping arm right
- Lateral clamping arm both sides



Base model with 4 lateral clamping arms, large gap between clamping arms

Lateral clamping arms | Technical Information

| Model | Clamping arm variant | Order no. for 1 set of lateral clamping arms (1 clamping arm) | Clamping position | Standard opening angle | B2 | B4 | B9 | B10 | B11 | B12 |
|-----------------------|--|---|-------------------|------------------------|-----|----|----|-----|-----|-----|
| 82D63-523C900B | lateral, left lateral, right lateral, both sides | 8JG-070-1-01 | vertical | 180° | 144 | 74 | 9 | 30 | 105 | 30 |

| Model | Clamping arm variant | Order no. for 1 set of lateral clamping arms (1 clamping arm) | B31 | D2 | D3 | L4 | L5 | L10 | L20 | L21 | R2 |
|-----------------------|--|---|-------|---------|----|----|----|-----|-----|-----|----|
| 82D63-523C900B | lateral, left lateral, right lateral, both sides | 8JG-070-1-01 | ±0,02 | H7 ∅ | ∅ | 28 | 15 | 20 | 20 | 136 | 28 |

Drawing shows standard mounting (L20) with four lateral clamp arms

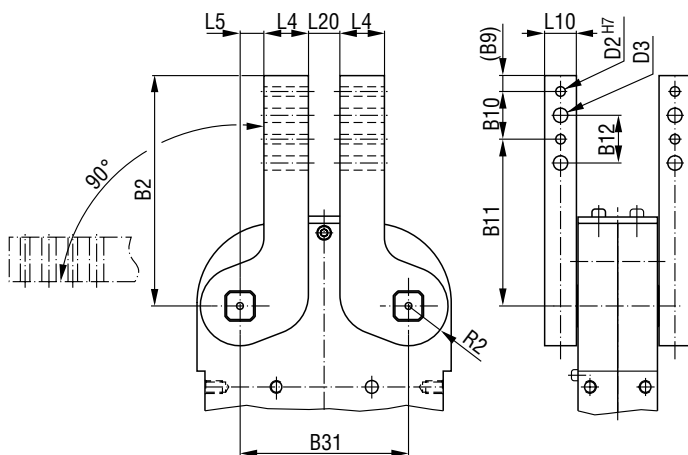

Drawing shows further mounting possibility (L21)

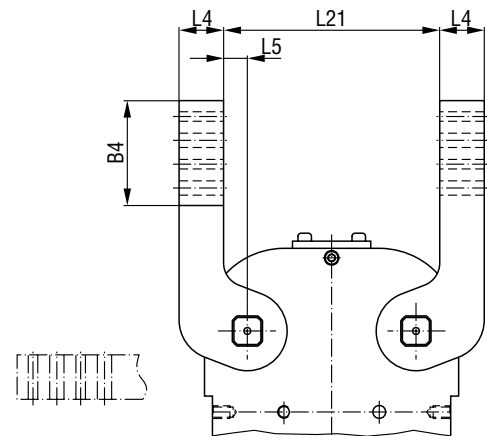

82D40-2/82D63-5 SERIES

Pneumatic Power Clamps | Technical Specifications

Wiring diagram of electrical sensing system

Sensing system immune to interference from d.c. arc welding and a.c. arc welding

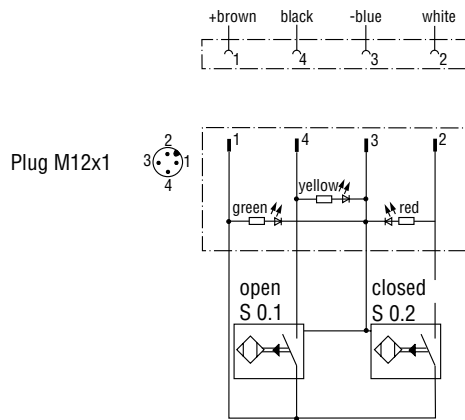

Concept guideline (with reference to axis of clamping arm rotation)

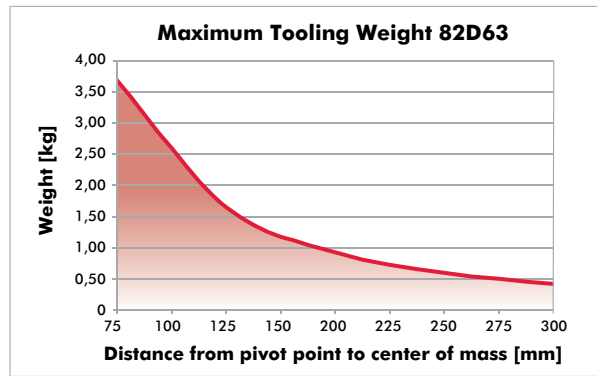
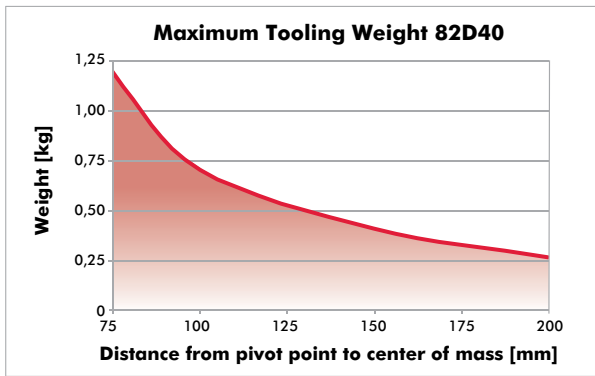

All details apply under an air pressure of 6 bar and opening and closure times of 1 second each

Diagram of clamping torque

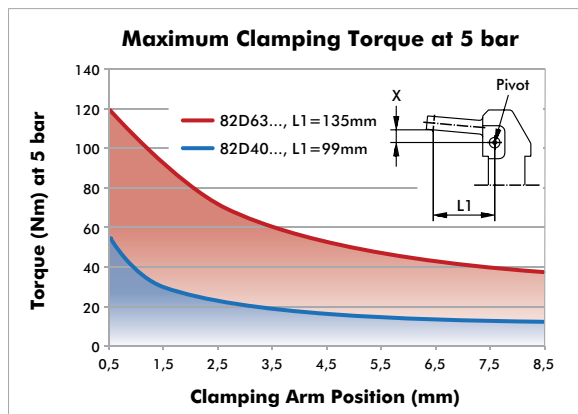

82D40-2/82D63-5 ACCESSORIES

Pneumatic Power Clamps | Technical Specifications

| Clamping Arms | | Order no. for Structural component | | Comment |
|----------------------|-------------------|------------------------------------|----------------------------------|---|
| Clamping are variant | Clamping position | 82D40-223C900B | 82D63-523C900B | |
| U-central | vertical | 8JG-065-1-01 | 8JG-069-1-01 | sets of U-type clamping arms consist of clamping arm, links and screws |
| lateral right/left | vertical | 8JG-066-1-01¹⁾ | 8JG-070-1-01²⁾ | sets of lateral clamping arms consist of 1) clamping arm, links and screws 2) clamping arm and set screws you need 2 sets of clamping arms |
| lateral both sides | vertical | 8JG-066-1-01¹⁾ | 8JG-070-1-01²⁾ | you need 4 sets of clamping arms |



Connector socket
M12x1 straight, 5-pin

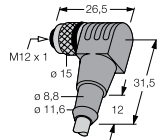

Connector socket
M12x1 angular, 4-pin

| Connector Cable (includes 1 connector socket & 5 m cable) | Order no. for Structural component | |
|--|------------------------------------|------------------|
| | 82D40-223C900 | 82D63-523C900 |
| Connector socket M12x1 straight, 5-pin | 8EL-002-1 | 8EL-002-1 |
| Connector socket M12x1 angular, 4-pin | 8EL-003-1 | 8EL-003-1 |

| Opening Angle Limiter | Order no. for Structural component | | | |
|-----------------------|------------------------------------|------------------|---------------|------------------|
| | 82D40-223C900 | | 82D63-523C900 | |
| Angle | Length | Order No. | Length | Order No. |
| 180° (Standard) | 11,4mm | 8CE-342-1 | 14,4mm | 8CE-362-1 |
| 160° | 15,1mm | 8CE-340-1 | 20,0mm | 8CE-360-1 |
| 140° | 18,5mm | 8CE-338-1 | 24,8mm | 8CE-358-1 |
| 120° | 22,2mm | 8CE-336-1 | 29,6mm | 8CE-356-1 |
| 100° | 25,8mm | 8CE-334-1 | 34,3mm | 8CE-354-1 |
| 80° | 28,0mm | 8CE-332-1 | 39,0mm | 8CE-352-1 |
| 60° | 33,0mm | 8CE-330-1 | 43,8mm | 8CE-350-1 |
| 40° | 37,0mm | 8CE-328-1 | 49,1mm | 8CE-348-1 |
| 20° | 41,8mm | 8CE-326-1 | 56,2mm | 8CE-346-1 |

| Shim Plates (for clamping arm) | Fit for model 82D40-2 | | | | | | | | Fit for model 82D63-5 | | | | | | | | | |
|-----------------------------------|-----------------------|----|-----|-----|----|----|-----|-----|-----------------------|--------------------|----|-----|-----|----|----|-----|-----|-----|
| | Model | A1 | A2 | D2 | D3 | B9 | B10 | B12 | L10 | Model | A1 | A2 | D2 | D3 | B9 | B10 | B12 | L10 |
| | 82ZB-SH4001 | | 0,1 | | | | | | | 82ZB-SH5001 | | 0,1 | | | | | | |
| | 82ZB-SH4002 | | 0,2 | | | | | | | 82ZB-SH5002 | | 0,2 | | | | | | |
| | 82ZB-SH4005 | 42 | 0,5 | 6,5 | 7 | 6 | 20 | 20 | 12 | 82ZB-SH5005 | 65 | 0,5 | 6,5 | 9 | 10 | 30 | 30 | 16 |
| | 82ZB-SH4010 | | 1,0 | | | | | | | 82ZB-SH5010 | | 1,0 | | | | | | |
| | 82ZB-SH4020 | | 2,0 | | | | | | | 82ZB-SH5020 | | 2,0 | | | | | | |
| | 82ZB-SH4050 | | 5,0 | | | | | | | 82ZB-SH5050 | | 5,0 | | | | | | |

| Spare Parts | Order no. for Structural component | |
|--|------------------------------------|------------------|
| | 82D40-2 | 82D63-5 |
| Cylinder | 8PW-016-1 | 8PW-024-2 |
| Integrated sensing system C9 Connector plug M12x1 | 8EA-024-2 | 8EA-024-2 |