

# OVERLOAD CLUTCHES

Features, Table of Contents



## Features:

**CAMCO Output Overload Clutches** are designed to protect your indexing equipment from costly downtime due to overload or jam conditions by quickly disengaging the drive system.

Easily Mounted to CAMCO index drives

Single Position reset to maintain accuracy and machine timing

Precision hardened and ground plungers and drive plate

Overload Detector plate provides actuation for overload detector switch

Variety of Models for all applications

Standard & custom torque settings

## Table of Contents

Overview .....	IN-CLU-3
D .....	IN-CLU-5
F .....	IN-CLU-6
S .....	IN-CLU-7
F .....	IN-CLU-8
C .....	IN-CLU-9
S-SD .....	IN-CLU-10
FC-SD .....	IN-CLU-11
C-SD .....	IN-CLU-12

# OVERLOAD CLUTCHES

## Mounting Overview

**CAMCO Output Overload Clutches** quickly disengage the drive system in overload or jam conditions, protecting indexers from costly downtime. A variety of models are available in standard and custom torque settings. An overload detector plate provides actuation for the overload detector switch, and the clutch's single-position reset function maintains accuracy and machine timing.

- Standard and custom torque settings
- Single-position reset maintains timing, accuracy
- Range of models for all applications
- Rigid, backlash-free design



Indexer Type	Clutch Type
RDM	D (Flange Mounted Body)
RD	
<b>Roller Gear (RGS / RGD)</b> <b>Parallel (P)</b> <b>Right Angle (RA)</b>	F (Flange to Flange)
	FC (Flange to Shaft)
	FC-SD (Flange to Shaft, Shrink-Disk)
	S (Shaft to Flange)
	S-SD (Shaft to Flange, Shrink-Disk)
	C (Shaft to Shaft Mounting)
	C-SD (Shaft to Shaft, Shrink-Disk)

### CAMCO Output Overload Clutches

#### **D Clutch: Flange-Mounted Body**

For CAMCO Index Drives with large dial mounting surfaces. The dial plate rests directly on the index drive output flange, providing stability and accuracy.

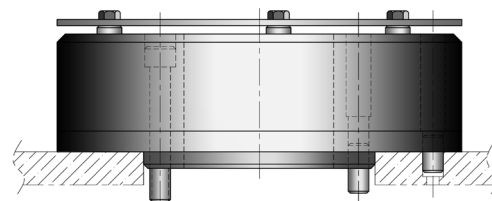

# OVERLOAD CLUTCHES

## Configurations

### CAMCO Output Overload Clutches

#### F Clutch: Flange-Mounted Body

F clutches are designed to mount a dial/sprocket/flanged component to a shaft output CAMCO index drive. These clutches will flange mount to the output shaft, providing a rigid, compact, and accurate connection with the driven member.

F clutches may be mounted in two positions, "A" (right, top) or "B" (right, bottom). Mounting "B" provides greater rigidity and overhung loading and should be used whenever high loads are exerted on driven members.

#### A Mounting

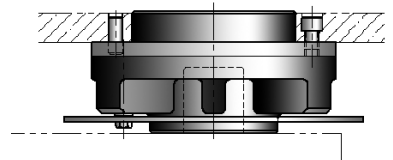

#### B Mounting

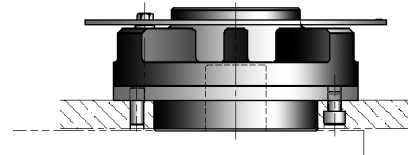

#### S & S-SD Clutch: Shaft to Flange

S clutches are designed to mount on CAMCO index drives without output flanges. The combination of key and clamped hub design provides a rigid and backlash-free connection.

S clutches may be mounted two positions, "A" or "B." Mounting "B" provides greater rigidity and overhung loading and should be used whenever high loads are exerted on driven members.

The S-SD clutch employs a shrink disk to connect to the shaft.

#### A Mounting

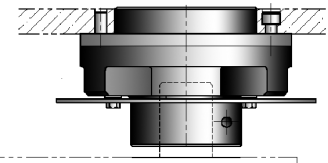

#### B Mounting

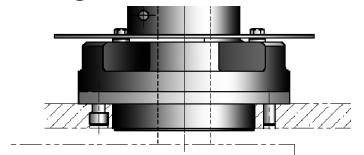

#### FC & FC-SD Clutch: Flange to Shaft

FC clutches are designed to mount on CAMCO index drives with flanged output shafts. These clutches will flange mount to the output shaft, providing a rigid, compact and accurate connection. The FC-SD clutch employs a shrink disk to connect to the shaft.

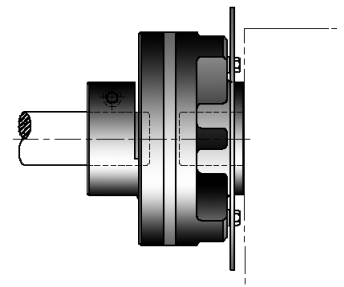

#### C Clutch: Shaft to Shaft

C clutches are designed to mount on CAMCO index drives without output flanges. These clutches are used whenever a positive connection is required between two shafts. The C-SD clutch employs shrink disks at both ends to connect to the shafts.

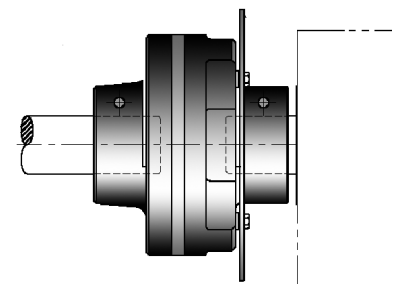

# D TYPE FLANGE-MOUNTED BODY

## Overload Clutches | Product Overview, Technical Information

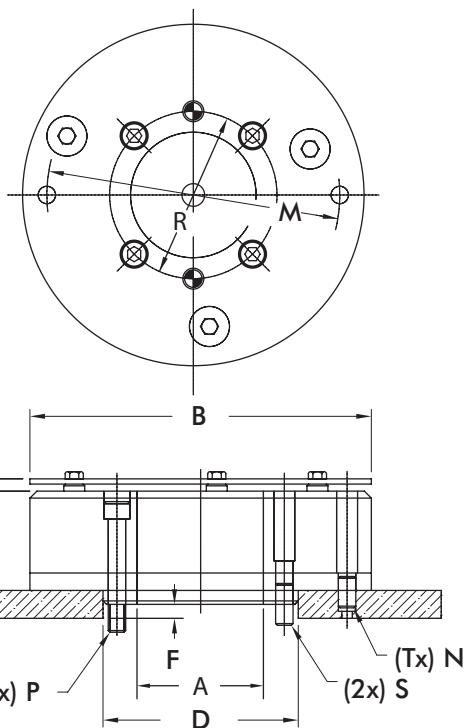

“D” Type clutches are designed to mount on CAMCO Index Drives with large dial mounting surfaces. The dial plate rests directly on the index drive output flange, providing stability and accuracy.

### D Type Dimensions

Model	A	B	C	D	E	F	G	M	N	P	Q	R	S	T
<b>2.8D</b>	1.00	5.12	2.50	2.500	0.22	0.250	0.500	4.250	0.312	.312-18	4	2.00	0.31	2
<b>4.0D</b>	2.25	6.12	2.50	3.500	0.22	0.250	0.500	5.250	0.312	.312-18	4	3.00	0.31	2
<b>7.8D</b>	3.41	8.50	2.88	5.000	0.25	0.188	0.750	6.750	0.500	.500-20	4	4.25	0.50	2
<b>18D</b>	2.62	10.25	4.53	5.000	0.31	0.188	1.000	8.250	0.625	.500-20	4	4.25	0.50	2
<b>31D</b>	5.25	14.50	4.03	9.000	0.34	-	1.000	11.750	0.750	.500-20	6	8.25	0.50	4
<b>32D</b>	5.25	14.50	4.03	9.000	0.34	-	1.000	11.750	0.750	.500-13	6	8.25	0.50	4
<b>33D (mm)</b>	133	368	102	228.6	8.4***	-	25	298.5	20	M12	6	210	12	4
<b>61D</b>	7.25	18.38	5.40	11.000	0.34	-	1.250	16.000	0.750	.625-11	8	10.00	.625 (4)	4

\* Dimension increases .06 during overload

\*\* Dimension increases .09 during overload

\*\*\* Dimension increases .12 during overload

### D Type Specifications

Model	Internal Inertia	Torque Setting	Index Drive
<b>2.8D</b>	29	400 480 700 850 1100 1300 1800 2200 3100	425RD
<b>4.0D</b>	69	420 620 750 1150 1750 2950 4000	601RDM
<b>7.8D</b>	266	1400 1700 2600 3200 4200 5000 7200 10000	902RDM 663RAD 900RAD
<b>18D</b>	743	5000 7000 7800 10,000 13000 15000 20000 25000	900RAD
<b>31D</b>	2910	8500 13000 20000 31000	1200RAD
<b>32D</b>	2910	8500 13000 20000 31000	1305RDM
<b>33D</b>	2910	8500 13000 20000 25500	1100RDM
<b>61D</b>	4900	23000 36000 44000 50000 60000	1800RDM

# F TYPE SHAFT TO FLANGE MOUNTING

## Overload Clutches | Product Overview, Technical Information

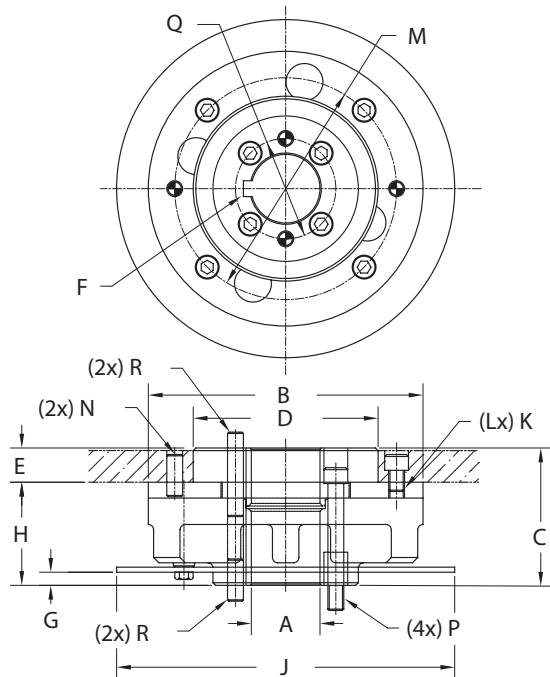

IMC "F" type clutches are designed to mount on IMC index drives. These clutches will flange mount to the output shaft, providing a rigid, compact, and accurate connection with the driven member.

### F Type Dimensions

Model	A	B	C	D	E	F	G	H	J	K	L	M	N	P	Q	R
.39F	0.625	3.38	2.19	2.375	0.41	0.1875	.22†	1.78	4.75	Oct-32	4	2.875	0.25	Oct-32	1.25	0.25
2.3F	1.000*	5.12	2.78	3.5	0.56	0.25	.22†	2.22	6.5	5/16/24	4	4.25	0.312	5/16/24	2	0.31
6.0F	1.625	6.5	3.25	4.375	0.81	0.375	.31††	2.44	8	3/8/24	4	5.25	0.375	3/8/24	2.38	0.38
11F	2	8.5	3.72	5.75	0.81	0.5	.38††	2.91	10	3/8/24	4	6.75	0.5	3/8/24	3.25	0.5
25F	2.75	10.25	4.97	7.125	1.06	0.625	.38†††	3.91	12	1/2/13	6	8.25	0.625	1/2/20	4.25	0.63

\* Also 1.250

† Dimension decreases .06 during overload  
 †† Dimension decreases .09 during overload  
 ††† Dimension decreases .12 during overload  
 †††† Dimension decreases 1.5 mm during overload

### F Type Specifications

Model	Internal Inertia	Torque Setting	Index Drive
.39F	5	160 210 270 320 390	250P
2.3F	32	400 600 700 850 1000 1300 1800 2000 230	387P 350RGS/RGD 400RA
6.0F	87	670 825 1100 1400 1700 2000 2300 2500 3000 3800 4000 5000 6000	512P 512RA
11F	340	2300 4000 6000 8500 11000	662P 662RA
25F	842	5000 7000 10000 13000 15000 20000 25000	900P

# S TYPE SHAFT TO FLANGE MOUNTING SERIES

## Overload Clutches | Product Overview, Technical Information

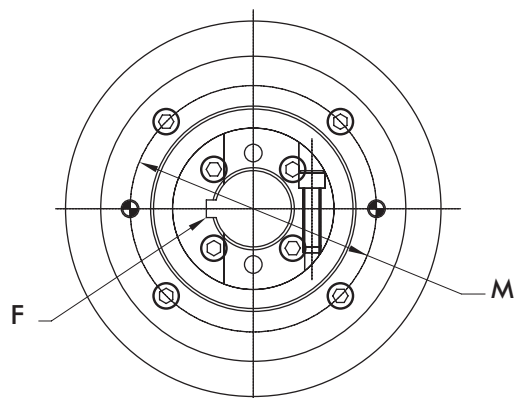

IMC "S" type clutches are designed to mount on CAMCO index drives without output flanges. The combination of key and clamped hub design provides a rigid and backlash-free connection.

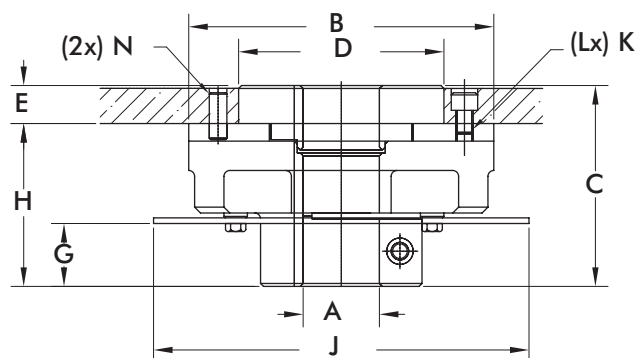

### S Type Dimensions

Model	A	B	C	D	E	F	G	H	J	K	L	M	N
.39S	0.6250	3.38	2.63	2.375	0.40	0.187	.66†	2.22	4.75	10-32	4	2.88	0.250
2.3S	1.0000**	5.12	3.31	3.500	0.56	0.250	.75†	2.75	6.50	5/16-24	4	4.25	0.312
6.0S	1.6250	6.50	4.28	4.375	0.81	0.375	1.34††	3.47	8.00	3/8-24	4	5.25	0.375
11S	2.0000	8.50	5.00	5.750	0.81	0.500	1.69††	4.19	10.00	3/8-24	4	6.75	0.500
25S	2.5000	10.25	6.25	7.125	1.06	0.625	1.66†††	5.19	12.00	1/2-13	6	8.25	0.625

\* Dimensions in millimeters

\*\* Also 1.2500

† Dimension decreases .06 during overload

†† Dimension decreases .09 during overload

††† Dimension decreases .12 during overload

†††† Dimension decreases 1.5 mm during overload

### S Type Specifications

Model	Internal Inertia	Torque Setting	Index Drive
.39S	5	160 210 270 320 390	250P
2.3S	31	400 600 700 850 1000 1300 1800 2000 2300	387P 350RGS/RGD 400RA
6.0S	83	670 825 1100 1400 1700 2000 2300 2500 3000 3800 4000 5000 6000	512P 512RA
11S	320	2300 4000 6000 8500 11000	500RGD/RGS 662RA 662P
25S	803	5000 7000 10000 13000 15000 20000 25000	700RGS

# FC TYPE FLANGE TO SHAFT MOUNTING SERIES

## Overload Clutches | Product Overview, Technical Information

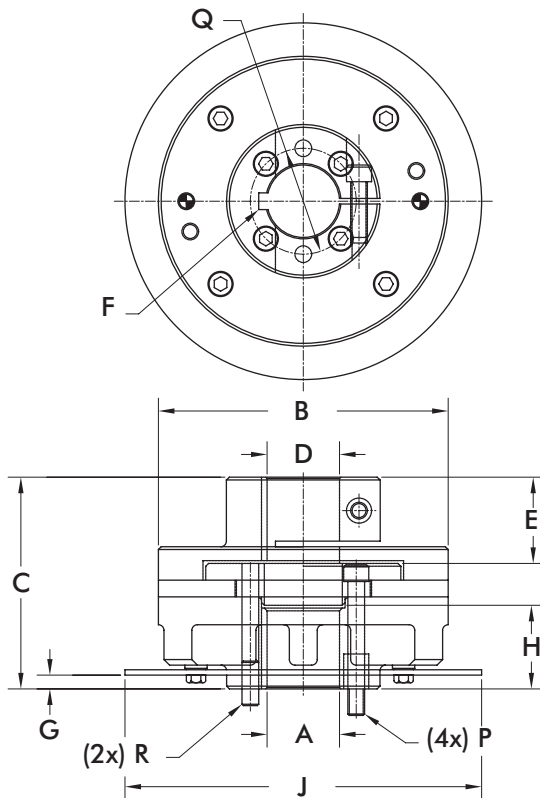

"FC" type clutches are designed to mount on CAMCO index drives. These clutches will flange mount to the output shaft, providing a rigid, compact and accurate connection.

### FC Type Dimensions

Model	A	B	C	D	E	F	G	H	J	P	Q	R
.39FC	0.6250	3.38	3.03	0.625	1.06	0.187	.22†	1.41	4.75	10-32	1.25	0.25
2.3FC	1.0000**	5.12	3.81	1.000	1.28	0.250	.22†	1.75	6.50	5/16-24	2.00	0.31
6.0FC	1.6250	6.50	4.75	1.625	1.94	0.375	.31††	1.88	8.00	3/8-24	2.38	0.38
11FC	2.0000	8.50	5.72	2.000	2.38	0.500	.38††	2.25	10.00	3/8-24	3.25	0.38

\* Dimensions in millimeters

\*\* Also 1.2500

† Dimension decreases .06 during overload

†† Dimension decreases .09 during overload

††† Dimension decreases .12 during overload

†††† Dimension decreases 1.5 mm during overload

### FC Type Specifications

Model	Internal Inertia	Torque Setting	Index Drive
.39FC	7	160 210 270 320 390	250P
2.3FC	43	400 600 700 850 1000 1300 1800 2000 2300	387P 350RGS/RGD 400RA
6.0FC	118	670 825 1100 1400 1700 2000 2300 2500 3000 3800 4000 5000 6000	512P 512RA
11FC	456	2300 4000 6000 8500 11000	662P 662RA

# C TYPE SHAFT TO SHAFT MOUNTING SERIES

## Overload Clutches | Product Overview, Technical Information

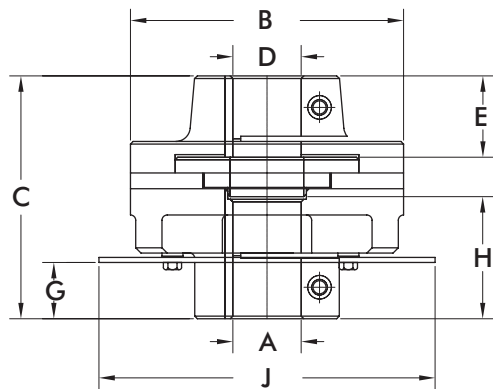
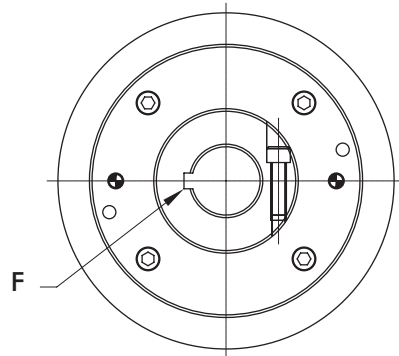

"C" type clutches are designed to mount on CAMCO index drives without output flanges. These clutches are used whenever a positive connection is required between two shafts.

### C Type Dimensions

Model	A	B	C	D	E	F	G	H	J	P	Q	R
.39C	0.6250	3.38	3.03	0.625	1.06	0.187	.22†	1.41	4.75	10-32	1.25	0.25
2.3C	1.0000**	5.12	3.81	1.000	1.28	0.250	.22†	1.75	6.50	5/16-24	2.00	0.31
6.0C	1.6250	6.50	4.75	1.625	1.94	0.375	.31††	1.88	8.00	3/8-24	2.38	0.38
11C	2.0000	8.50	5.72	2.000	2.38	0.500	.38††	2.25	10.00	3/8-24	3.25	0.38

\* Dimensions in millimeters

\*\* Also 1.2500

† Dimension decreases .06 during overload

†† Dimension decreases .09 during overload

††† Dimension decreases .12 during overload

†††† Dimension decreases 1.5 mm during overload

### C Type Specifications

Model	Internal Inertia	Torque Setting	Index Drive
.39C	7	160 210 270 320 390	250P
2.3C	44	400 600 700 850 1000 1300 1800 2000 2300	387P 350RGS/RGD 400RA
6.0C	122	670 825 1100 1400 1700 2000 2300 2500 3000 3800 4000 5000 6000	512P 512RA
11C	476	2300 4000 6000 8500 11000	500RGD/RGS 662P



# S-SD TYPE SHAFT TO FLANGE, SHRINK-DISK MOUNTING SERIES

Overload Clutches | Product Overview, Technical Information

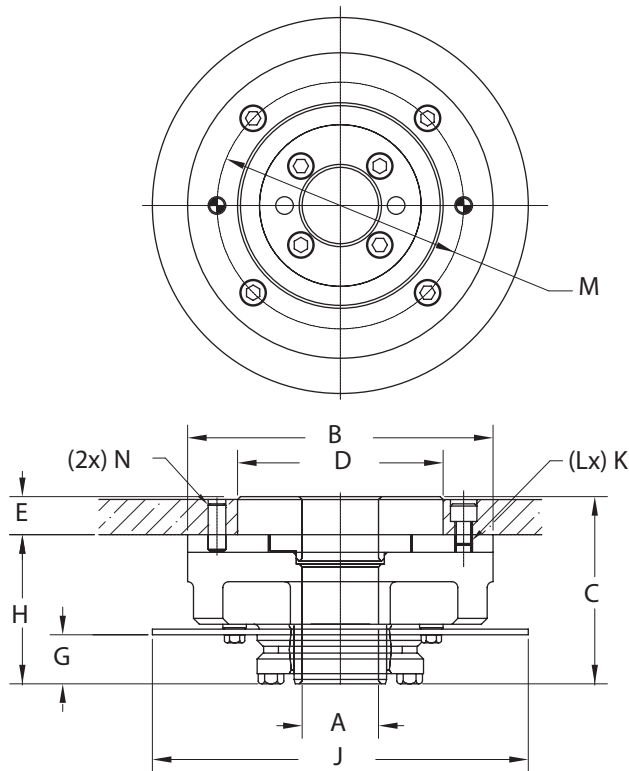

"S-SD" type clutches are designed to mount on CAMCO index drives without output flanges. The shrink disk design converts clamp loads from multiple high strength locking screws to radial gripping force through the use of circular wedges, providing the highest capacity mechanical interference connection available.

## S-SD Type Dimensions

Model	A	B	C	D	E	F	G	H	J	K	L	N
.39-SD	0.6250	3.38	2.62	2.375	0.40	.66†	2.22	4.75	10-32	4	2.88	0.250
2.3-SD	1.0000	5.12	3.31	3.500	0.56	.75†	2.75	6.50	5/16-24	4	4.25	0.312
6.0-SD	1.6250	6.50	3.98	4.375	0.81	1.04††	3.17	8.00	3/8-24	4	5.25	0.375
11-SD	2.0000	8.50	4.38	5.750	0.82	1.06††	3.56	10.00	3/8-24	4	6.75	0.500

\* Dimensions in millimeters

† Dimension decreases .06 during overload

†† Dimension decreases .09 during overload

††† Dimension decreases .12 during overload

†††† Dimension decreases 1.5 mm during overload

## S-SD Type Specifications

Model	Internal Inertia	Torque Setting	Index Drive
.39-SD	5	160 210 270 320 390	250P
2.3-SD	32	400 600 700 850 1000 1300 1800 2000 2300	387P 350RGS/RGD 400RA
6.0-SD	87	670 825 1100 1400 1700 2000 2300 2500 3000 3800 4000 5000 6000	512P 512RA
11-SD	340	2300 4000 6000 8500 11000	500RGD/RGS 662P

# FC-SD TYPE FLANGE TO SHAFT, SHRINK-DISK MOUNTING SERIES

## Overload Clutches | Product Overview, Technical Information

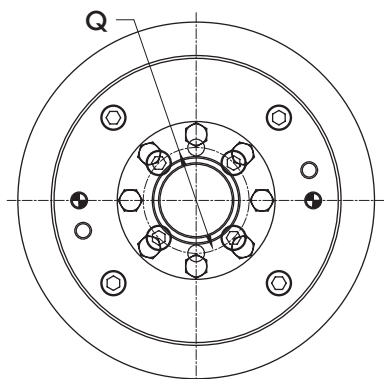

“FC-SD” type clutches are designed to mount on CAMCO index drives with output flanges. The shrink disk design converts clamp loads from multiple high strength locking screws to radial gripping force through the use of circular wedges, providing the highest capacity mechanical interference connection available.

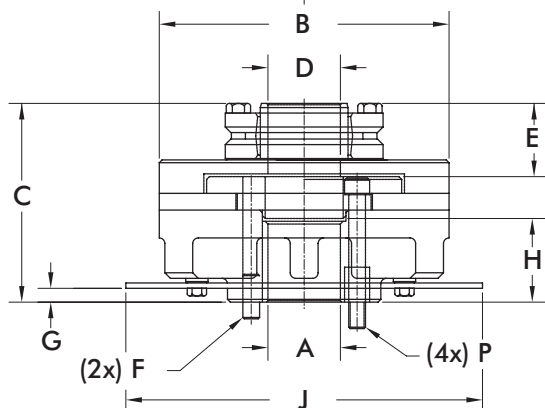

### FC-SD Type Dimensions

Model	A	B	C	D	E	F	G	H	J	P	Q
.39FC-SD	0.6250	3.38	3.00	0.625	1.03	0.25	.22†	1.41	4.75	10-32	1.25
2.3FC-SD	1.0000	5.12	3.81	1.000	1.27	0.31	.22†	1.75	6.50	5/16-24	2.00
6.0FC-SD	1.6250	6.50	4.46	1.625	1.64	0.38	.31††	1.88	8.00	3/8-24	2.38
11FC-SD	2.0000	8.50	5.06	2.000	1.75	0.38	.38††	2.25	10.00	3/8-24	3.25

\* Dimensions in millimeters

† Dimension decreases .06 during overload

†† Dimension decreases .09 during overload

††† Dimension decreases .12 during overload

†††† Dimension decreases 1.5 mm during overload

### FC-SD Type Specifications

Model	Internal Inertia	Torque Setting	Index Drive
.39FC-SD	7	160 210 270 320 390	250P
2.3FC-SD	34	400 600 700 850 1000 1300 1800 2000 2300	387P 350RGS/RGD 400RA
6.0FC-SD	118	670 825 1100 1400 1700 2000 2300 2500 3000 3800 4000 5000 6000	512P 512RA
11FC-SD	456	2300 4000 6000 8500 11000	500RGD/RGS 662P 662RA

# C-SD TYPE SHAFT TO SHAFT, SHRINK-DISK MOUNTING SERIES

## Overload Clutches | Product Overview, Technical Information

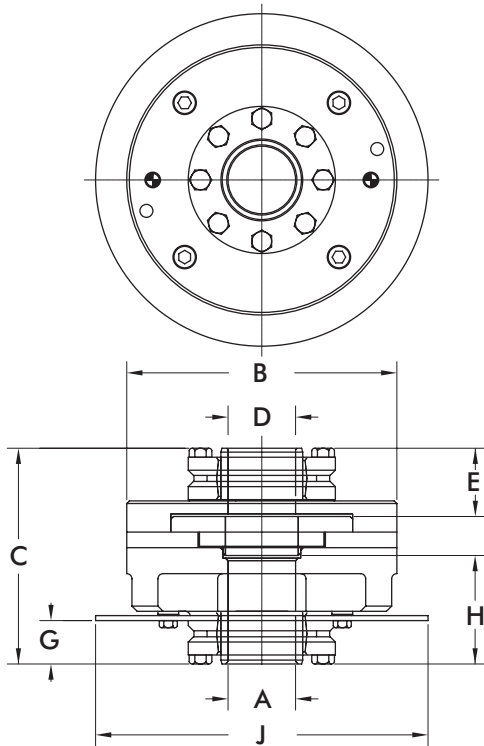

"C-SD" type clutches are designed to mount on CAMCO index drives without output flanges. The shrink disk design converts clamp loads from multiple high strength locking screws to radial gripping force through the use of circular wedges, providing the highest capacity mechanical interference connection available.

### C-SD Type Dimensions

Model	A	B	C	D	E	G	H	J
.39C-SD	0.6250	3.38	3.44	0.625	1.03	.66†	1.84	4.75
2.3C-SD	1.0000	5.12	4.34	1.000	1.28	.75†	2.28	6.50
6.0C-SD	1.6250	6.50	5.19	1.625	1.64	1.04††	2.61	8.00
11C-SD	2.0000	8.50	5.75	2.000	1.75	1.06††	2.93	10.00

\* Dimensions in millimeters

† Dimension decreases .06 during overload

†† Dimension decreases .09 during overload

††† Dimension decreases .12 during overload

†††† Dimension decreases 1.5 mm during overload

### C-SD Type Specifications

Model	Internal Inertia	Torque Setting	Index Drive
.39C-SD	7	160 210 270 320 390	250P
2.3C-SD	44	400 600 700 850 1000 1300 1800 2000 2300	387P 350RGS/RGD 400RA
6.0C-SD	122	670 825 1100 1400 1700 2000 2300 2500 3000 3800 4000 5000 6000	512P 512RA
11C-SD	476	2300 4000 6000 8500 11000	500RGD/RGS 662P 662RA