

8700 SERIES

Pneumatic Swing Clamps | Product Overview

Features:

- Alternative solution to swing clamps when space is limited
- The clamping lever may be positioned left, forward, or right (relative to ports) within the same clamp body
- Threaded body with upper flange mount
- Non-toggle locking linkage
- Clamping arm and spindle included

Applications:

- Assembly & welding fixtures
- Light machining

Also Available:

See page 39 for jam nuts

8725



8732
8732G



8740
8740G



8750
8750G



Technical Information

Model	Vertical Clamping Stroke* [in.]mm	Clamping Force† [lb.]N	Bore Size [in.]mm	Air Consumption‡ [in. ³]cm ³	Weight [lb.]kg	Seal Kit
8725	[0.10] 2,5	[43] 195	[0.98] 25	[0.004] 0,11	[1.3] 0,6	872500
8732	[0.12] 3,2	[64] 285	[1.26] 32	[0.008] 0,23	[2.2] 1,0	873200
8740		[106] 470	[1.57] 40	[0.014] 0,41	[2.6] 1,2	874000
8740G						
8750	[0.15] 3,8	[167] 745	[1.97] 50	[0.023] 0,64	[4,4] 2,0	875000
8750G						

* Equal to approx. 6° above horizontal with standard clamping arm. † at 5bar [72psi].

‡ per double stroke at 5bar [72psi].

Operating Pressure Range:

3bar [40psig] to 7bar [100psig]

Max. Operating Temperature:

-10°C to 80°C [14°F to 175°F]

Application Note:

If using clamping arms other than standard, the length must not exceed 1.5X the overall length of the standard arm.

The inlet air flow rate should be adjusted to position the arm in no less than 1/2 second for standard arms and no less than 1 second in the case of an extended arm.

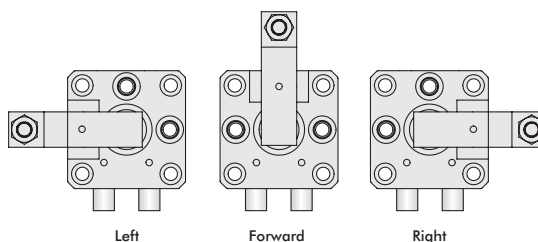

Levers can be positioned in one of three positions in relation to the air ports.

8700 SERIES

Pneumatic Swing Clamps | Dimensions, Clamping Forces

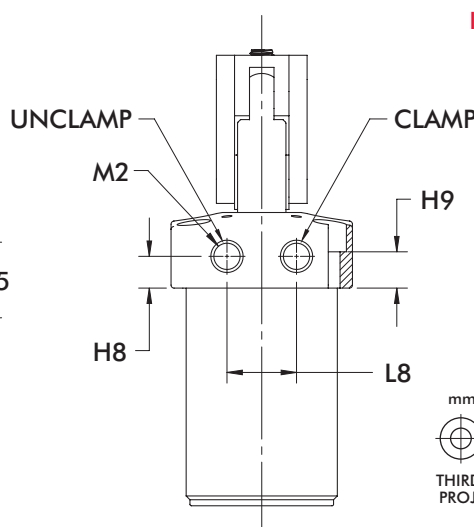
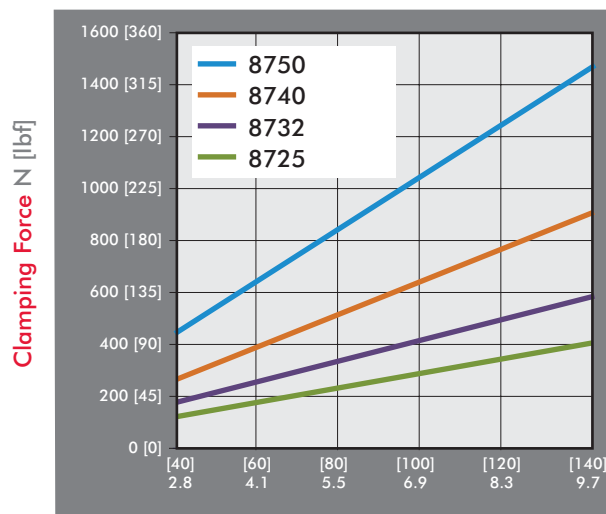
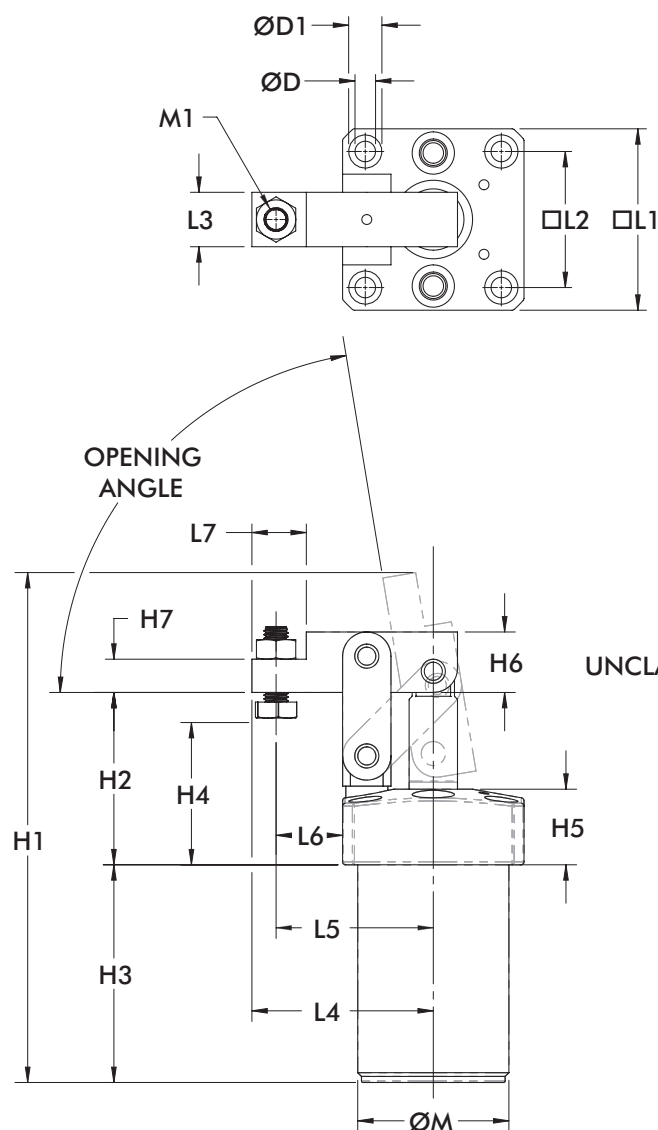

Inlet Pressure bar [PSI]

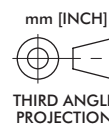

Model	Opening Angle	ØD	ØD1	H1	H2	H3	H4 (min/max)	H5	H6	H7	H8	H9
8725	80°	[0.22] 5,5	[0.35] 9	[5.67] 144	[1.97] 50	[2.42] 61,5	[0.59-0.98] 15-25	[0.98] 25	[0.67] 17	[0.39] 10	[0.47] 12	[0.59] 15
8732/ 8732G	81°	[0.27] 6,8	[0.43] 11	[6.65] 169	[2.25] 57	[2.83] 72	[0.63-1.18] 16-30		[0.79] 20	[0.43] 11	[0.41] 10,5	[0.51] 13
8740/ 8740G	82°	[0.27] 6,8	[0.43] 11	[6.93] 176	[2.40] 61	[2.85] 72,5	[0.75-1.14] 19-29		[0.98] 25	[0.55] 14		[0.41] 10,5
8750/ 8750G	75°	[0.33] 8,5	[0.55] 14	[7.87] 200	[2.60] 66	[3.11] 79	[0.86-1.30] 22-33		[1.18] 30	[0.59] 15	[0.41] 10,5	[0.43] 11

Model	L1	L2	L3	L4	L5	L6	L7	L8	ØM	M1	M2
8725	[1.97] 50	[1.46] 37	[0.63] 16	[1.89] 48	[1.61] 41	[0.63] 16	[0.55] 14	[0.91] 23	M40 x 1.50	M6 x 1.0	M5 x 0.8
8732 8732G	[2.36] 60	[1.77] 45	[0.71] 18	[2.36] 60	[2.05] 52	[0.87] 22	[0.71] 18	[0.91] 23	M50 x 1.50	M8 x 1.25	[1/8NPT] G-1/8
8740 8740G	[2.65] 65	[1.97] 50	[0.79] 20	[2.60] 66	[2.20] 56	[0.93] 23,5	[0.79] 20	[1.02] 26	M55 x 1.50		[1/8NPT] G-1/8
8750 8750G	[2.95] 75	[2.28] 57	[0.87] 22	[3.05] 77,5	[2.50] 63,5	[1.02] 26	[1.10] 28	[1.26] 32	M65 x 1.50	M12 x 1.75	[1/8NPT] G-1/8

8700 SERIES

Pneumatic Swing Clamps | Jam Nuts

Features:

- For use with 8700 Series Pneumatic Lever Clamps
- Variable height adjustment
- For recessed mounting

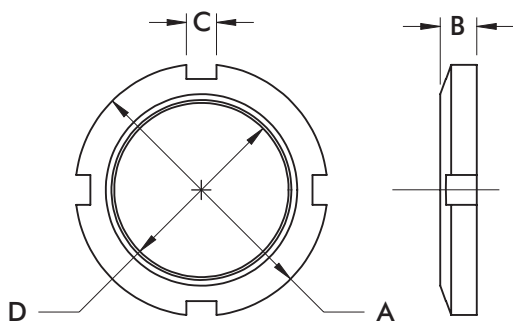

Mounting from above using 4 socket cap screws through the flange.

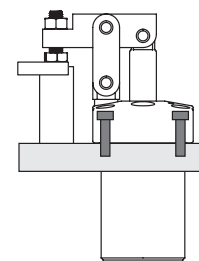

Mounting by screwing body into a tapped hole and locking with one jam nut.

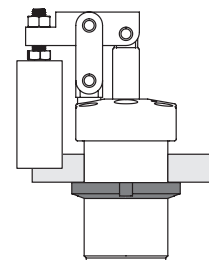

Mounting by inserting body into a plain hole and locking with two jam nuts.

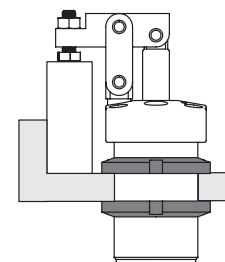

Part Number	Used with Model/series	A	B	C	D	Weight [lbs] kg
872550	8725	[2.09] 53	[0.35] 9	[0.28] 7	M40 x 1.50	[0.13] 0.06
873250	8732/ 8732G	[2.76] 70	[0.43] 11	[0.24] 6	M50 x 1.50	[0.35] 0.16
874050	8740/ 8740G	[2.95] 75		[0.31] 8	M55 x 1.50	[0.37] 0.17
875050	8750/ 8750G	[3.25] 82,5	[0.39] 10	[0.39] 10	M65 x 1.50	[0.33] 0.15

PNEUMATIC SWING CLAMPS

Notes
