

GTB SERIES

Globoidal (Roller Gear) Servo Positioner | Table of Contents



Features:

DESTACO's **CAMCO GTB Series** are lightweight, compact, high-accuracy programmable servo positioners.

The exceptional low profile high-torque output design supports the demands of high inertia load applications.

Available in four sizes, the GTB series units are lubricated for life and can be mounted in either horizontal or vertical orientations. The GTB Series feature the largest utility through hole diameter available for its size, making it ideal for space constrained machine applications.

Table of Contents

IN-SRV-#

Features & Benefits	2
How to Order	3
Motor Interface Adapter Selection	5
Specifications	9
Indexer Sizing	10
GTB40	11
GTB63	12
GTB80	15
GTB100	18

GTB SERIES

Globoidal (Roller Gear) Servo Positioner | Features & Benefits

Zero Backlash Roller Gear Cam Mechanism

Innovative roller gear design provides exceptionally smooth motion performance. The globoidal cam and output turret with integrated rollers are a preloaded system that delivers zero backlash for superior accuracy, stiffness and long term durability.

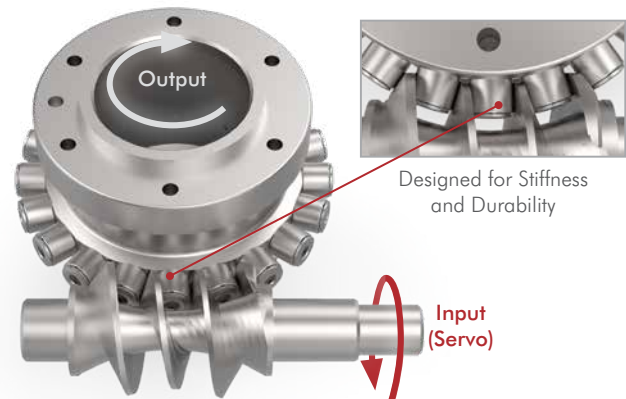

Flexible Drive Options

Each GTB model can be ordered in two different drive options. The high-torque gear drive option is used for applications with large inertia requirements while maintaining a small motor size. The direct drive option provides zero backlash, high precision operation. Both options interface with an array of servo motor suppliers.

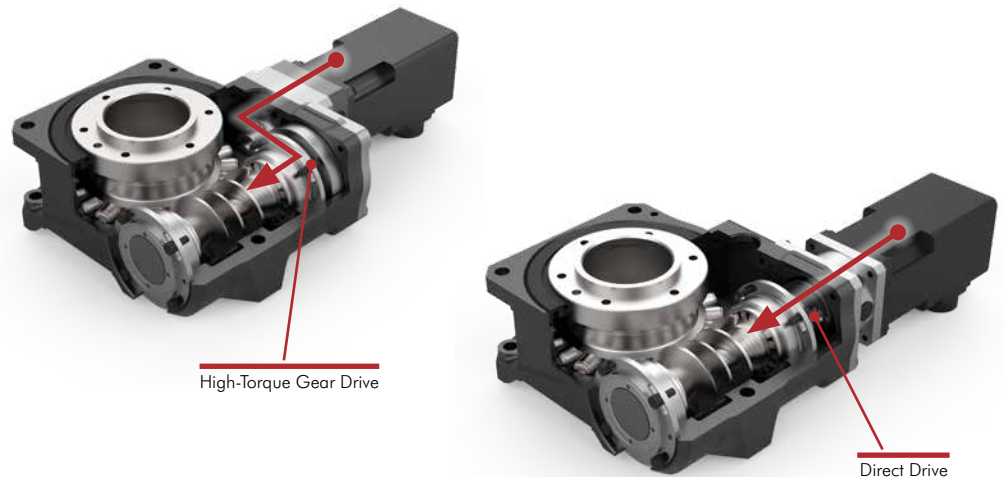

Orientation Independent Mounting

GTB Series units can be mounted in any orientation for easy installation and machine standardization.

Install units in any configuration:

- Flat horizontal table mounting
- Vertical mounting
- Trunnion Mounting
- Inverted (upside down) mounting



Trunnion Mount



Table Mount

GTB SERIES

Globoidal (Roller Gear) Servo Positioner | How To Order

GTB Series: How To Order

Globoidal (Roller Gear) Servo Positioner Base Unit

GTB Series units can be interfaced with wide variety of servo motor manufacturers. Use the MI code tables to identify the supported motors for each GTB unit. The MI code specifies the motor adapter plate that provides direct easy motor mounting to the GTB servo positioner.

The -H option for independent mounting orientation comes standard with every GTB series unit. The -T option for precision dial plate locating dowel hole and -B option for precision mounting dowel holes are also provided as standard.



GTB Series without motor installed

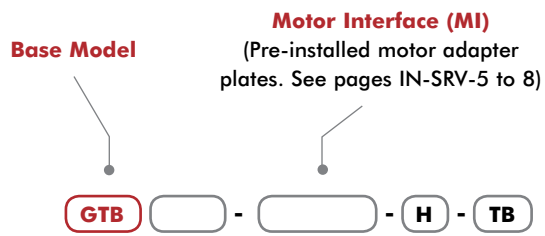

Easily Integrates with a Variety of Servo Motor Manufacturers

Allen Bradley Siemens
Mitsubishi Yaskawa
FANUC

Size	Supported Gear Ratios
40	45:1
	15:1
63	60:1
	20:1
80	60:1
	20:1
100	60:1
	20:1

- Standard Features**
- H** Orientation independent mounting. Supports vertical, horizontal, trunnion applications
 - T** Single output flange surface dowel hole for precision dial plate locating
 - B** Precision placement housing dowel holes, 2 on top of unit, 2 on bottom of unit

Units are available in two different gear ratios based on Direct or Geared motor coupling. See Motor Interface charts to determine what motors are supported for precision direct drive applications and geared drive high torque configurations.



Gear Drive:
High Inertia Applications
45:1 GTB40
60:1 GTB63, GTB80, GTB100



Direct Drive:
Zero Backlash Precision Applications
15:1 GTB40
20:1 GTB63, GTB80, GTB100

GTB SERIES

Globoidal (Roller Gear) Servo Positioner | How To Order

GTB Series: How to Order configured System (Allen Bradley only)

Servo Positioner Configured Systems

GTB Series units can be interfaced with wide variety of servo motor manufacturers. Use the MI code table to identify the supported motors for each GTB unit.

GTB series are also offered as a configured system when selecting Allen Bradley servo motors. The Allen Bradley servo motor will be installed to the GTB unit and shipped as a complete assembly. The GTB series and motor combinations are a matched pair that supports a variety of servo positioning rotary table applications. To use one of the configured systems you must verify the application requirements are within the operating parameters of the GTB unit and motor combination.



GTB Series with Allen Bradley Motor Installed*

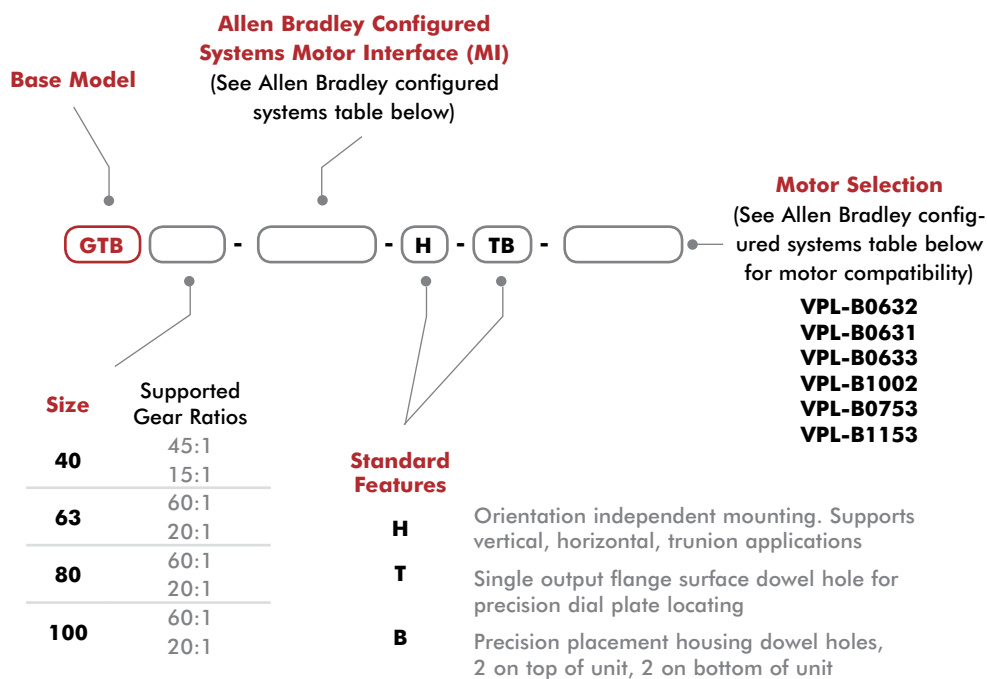

Allen Bradley Configured Systems

Size	Base Part #	Allen Bradley MI Code #	Motor Coupling	Gear Ratio	Motor Vendor	Allen Bradley Motor Part #	Motor Frame mm	Flange size mm	Shaft Ø mm
40	GTB40	FDG20	Direct	15:1	Allen Bradley	VPL-B0632	60	63	9
	GTB40	FGC20	Geared	45:1		VPL-B0631			
63	GTB63	GDP20	Direct	20:1		VPL-B0633			
	GTB63	GGC22	Geared	60:1		VPL-B0632			
80	GTB80	HDP20	Direct	20:1		VPL-B1002	100	100	16
	GTB80	HGD24	Geared	60:1		VPL-B0753	80	75	11
100	GTB100	JDG20	Direct	20:1		VPL-B1153	100	115	19
	GTB100	JGE27	Geared	60:1		VPL-B1153	100		

* = Servo Positioner units are assembled, tested and shipped with the above recommended motor for best performance.

GTB40

Servo Positioner Rotary Table | Motor Interface Adapter Selection

□ = Motor Frame Size

Ratio 45:1

Gear Drive: High Inertia Applications

Make / Series	Model	□ mm	kW	MI	Motor Shaft Bushing
Allen Bradley	VPL TLY-A130	40	0.14	FGA20	O
Allen Bradley	VPL VPL-B0631	60	0.19	FGC20*	O
Yaskawa	Σ5 SGMJV-01A	40	0.10	FGA20	-
Yaskawa	Σ5 SGMV-01A	40	0.10	FGA20	-
Yaskawa	Σ5 SGMV-C2A	40	0.15	FGA20	-
Yaskawa	Σ5 SGMJV-C2A	40	0.15	FGA20	-
Yaskawa	Σ7 SGM7J-01A	40	0.10	FGA20	-
Yaskawa	Σ7 SGM7J-C2A	40	0.15	FGA20	-
Yaskawa	Σ7 SGM7A-01A	40	0.10	FGA20	-
Yaskawa	Σ7 SGM7A-C2A	40	0.15	FGA20	-
Mitsubishi	J3 HF-KP13	40	0.10	FGA20	-
Mitsubishi	J3 HF-MP13	40	0.10	FGA20	-
Mitsubishi	J4 HG-KR13	40	0.10	FGA20	-
Mitsubishi	J4 HG-MR13	40	0.10	FGA20	-
Panasonic	A5 MSMD01	38	0.10	FGB20	-
Panasonic	A5 MSME01	38	0.10	FGB20	-
Panasonic	A6 MSMF01	38	0.10	FGB20	-
Panasonic	A6 MHMF01	40	0.10	FGA20	-
Sanyo	R2 R2AA04010F	40	0.10	FGA20	-

* Recommended Motor Interface with shortest lead time

Ratio 15:1

Direct Drive: Zero Backlash Precision Applications

Make / Series	Model	□ mm	kW	MI
Allen Bradley	VPL VPL-B0632	60	0.37	FDG20*
Allen Bradley	VPL VPL-B0752	70	0.67	FDH20
FANUC	β βiS0.5/6000	60	0.35	FDE20
FANUC	β βiS1/6000	60	0.50	FDA20
Mitsubishi	J3 HF-KP23	60	0.20	FDA20
Mitsubishi	J3 HF-KP43	60	0.40	FDA20
Mitsubishi	J3 HF-MP23	60	0.20	FDA20
Mitsubishi	J3 HF-MP43	60	0.40	FDA20
Mitsubishi	J4 HG-KR23	60	0.20	FDA20
Mitsubishi	J4 HG-KR43	60	0.40	FDA20
Mitsubishi	J4 HG-MR23	60	0.20	FDA20
Mitsubishi	J4 HG-MR43	60	0.40	FDA20
Panasonic	A5 MSMD02	60	0.20	FDC20
Panasonic	A5 MSMD04	60	0.40	FDD20
Panasonic	A5 MSME02	60	0.20	FDC20
Panasonic	A5 MSME04	60	0.40	FDD20
Panasonic	A5 MHMD02	60	0.20	FDC20
Panasonic	A5 MHMD04	60	0.40	FDD20
Panasonic	A6 MSMF02	60	0.20	FDC20
Panasonic	A6 MSMF04	60	0.40	FDD20
Panasonic	A6 MHMF02	60	0.20	FDC20
Panasonic	A6 MHMF04	60	0.40	FDD20
Sanyo	R2 R2AA06020F	60	0.20	FDA20
Sanyo	R2 R2AA06040F	60	0.40	FDA20
Sanyo	R2 R2AA06040H	60	0.40	FDA20
Yaskawa	Σ5 SGMV-02A	60	0.20	FDA20
Yaskawa	Σ5 SGMV-04A	60	0.40	FDA20
Yaskawa	Σ5 SGMV-06A	60	0.55	FDB20
Yaskawa	Σ5 SGMJV-02A	60	0.20	FDA20
Yaskawa	Σ5 SGMJV-04A	60	0.40	FDA20
Yaskawa	Σ5 SGMJV-06A	60	0.60	FDB20
Yaskawa	Σ7 SGM7A-02A	60	0.20	FDA20
Yaskawa	Σ7 SGM7A-04A	60	0.40	FDA20
Yaskawa	Σ7 SGM7A-06A	60	0.60	FDB20
Yaskawa	Σ7 SGM7J-02A	60	0.20	FDA20
Yaskawa	Σ7 SGM7J-04A	60	0.40	FDA20
Yaskawa	Σ7 SGM7J-06A	60	0.60	FDB20

* Recommended Motor Interface with shortest lead time

□ = Motor Frame Size Globoidal (Roller Gear) Servo Positioner | Motor Interface Adapter Selection

Ratio 60:1

Gear Drive: High Inertia Applications

Make / Series	Model	□ mm	kW	MI	Motor Shaft Bushing
Allen Bradley VPL	VPL-B0632	60mm	0.67	GGC22*	○
Allen Bradley VPL	VPL-B0752	70mm	0.67	GGE24	○
FANUC β	βiS05/6000	60	0.35	GGA22	○
FANUC β	βiS1/6000	60	0.50	GGA20	-
Mitsubishi J3	HF-KP23	60	0.20	GGA20	-
Mitsubishi J3	HF-KP43	60	0.40	GGA20	-
Mitsubishi J3	HF-MP23	60	0.20	GGA20	-
Mitsubishi J3	HF-MP43	60	0.40	GGA20	-
Mitsubishi J4	HG-KR23	60	0.20	GGA20	-
Mitsubishi J4	HG-KR43	60	0.40	GGA20	-
Mitsubishi J4	HG-MR23	60	0.20	GGA20	-
Mitsubishi J4	HG-MR43	60	0.40	GGA20	-
Panasonic A5	MSMD02	60	0.20	GGB21	○
Panasonic A5	MSMD04	60	0.40	GGB20	-
Panasonic A5	MSME02	60	0.20	GGB21	○
Panasonic A5	MSME04	60	0.40	GGB20	-
Panasonic A5	MHMD02	60	0.20	GGB21	○
Panasonic A5	MHMD04	60	0.40	GGB20	-
Panasonic A6	MSMF02	60	0.20	GGB21	○
Panasonic A6	MSMF04	60	0.40	GGB20	-
Panasonic A6	MHMF02	60	0.20	GGB21	○
Panasonic A6	MHMF04	60	0.40	GGB20	-
Sanyo R2	R2AA06020F	60	0.20	GGA20	-
Sanyo R2	R2AA06040F	60	0.40	GGA20	-
Sanyo R2	R2AA06040H	60	0.40	GGA20	-
Yaskawa Σ5	SGMAV-02A	60	0.20	GGA20	-
Yaskawa Σ5	SGMAV-04A	60	0.40	GGA20	-
Yaskawa Σ5	SGMAV-06A	60	0.55	GGA20	-
Yaskawa Σ5	SGMJV-02A	60	0.20	GGA20	-
Yaskawa Σ5	SGMJV-04A	60	0.40	GGA20	-
Yaskawa Σ5	SGMJV-06A	60	0.60	GGA20	-
Yaskawa Σ7	SGM7J-02A	60	0.20	GGA20	-
Yaskawa Σ7	SGM7J-04A	60	0.40	GGA20	-
Yaskawa Σ7	SGM7J-06A	60	0.60	GGA20	-
Yaskawa Σ7	SGM7A-02A	60	0.20	GGA20	-
Yaskawa Σ7	SGM7A-04A	60	0.40	GGA20	-
Yaskawa Σ7	SGM7A-06A	60	0.60	GGA20	-

* Recommended Motor Interface with shortest lead time

Ratio 20:1

Direct Drive: Zero Backlash Precision Applications

Make / Series	Model	□ mm	kW	MI
Allen Bradley VPL	VPL-B0633	60	0.65	GDP20*
Allen Bradley VPL	VPL-B0753	70	0.65	GDQ20
FANUC α	αiS2/5000	90	0.75	GDK20
FANUC α	αiS2/6000	90	1.00	GDK20
FANUC α	αiF1/5000	90	0.50	GDK20
FANUC α	αiF2/5000	90	0.75	GDK20
FANUC α	αiS1/6000	60	0.50	GDA20
FANUC α	αiS2/4000	90	0.50	GDK20
Mitsubishi J3	HF-KP43	60	0.40	GDA20
Mitsubishi J3	HF-KP73	80	0.75	GDB20
Mitsubishi J3	HF-MP43	60	0.40	GDA20
Mitsubishi J3	HF-MP73	80	0.75	GDB20
Mitsubishi J4	HG-KR43	60	0.40	GDA20
Mitsubishi J4	HG-KR73	80	0.75	GDB20
Mitsubishi J4	HG-MR43	60	0.40	GDA20
Mitsubishi J4	HG-MR73	80	0.75	GDB20
Panasonic A5	MSMD04	60	0.40	GDF20
Panasonic A5	MSMD08	80	0.75	GDG20
Panasonic A5	MSME04	60	0.40	GDF20
Panasonic A5	MSME08	80	0.75	GDG20
Panasonic A5	MHMD04	60	0.40	GDF20
Panasonic A5	MHMD08	80	0.75	GDG20
Panasonic A6	MSMF04	60	0.40	GDF20
Panasonic A6	MSMF08	80	0.75	GDG20
Panasonic A6	MSMF09	80	1.00	GDG20
Panasonic A6	MQMF04	80	0.40	GDH20
Panasonic A6	MHMF04	60	0.40	GDF20
Panasonic A6	MHMF08	80	0.75	GDG20
Panasonic A6	MHMF09	80	1.00	GDG20
Sanyo R2	R2AA06040H	60	0.40	GDA20
Sanyo R2	R2AA06040F	60	0.40	GDA20
Sanyo R2	R2AAB8075F	86	0.75	GDD20
Sanyo R2	R2AA08075F	80	0.75	GDJ20
Sanyo R2	R2AAB8100H	86	1.00	GDD20
Yaskawa Σ5	SGMAV-04A	60	0.40	GDA20
Yaskawa Σ5	SGMAV-06A	60	0.55	GDA20
Yaskawa Σ5	SGMAV-08A	80	0.75	GDB20
Yaskawa Σ5	SGMAV-10A	80	1.00	GDB20
Yaskawa Σ5	SGMGV-03A	90	0.30	GDC20
Yaskawa Σ5	SGMGV-05A	90	0.45	GDD20
Yaskawa Σ5	SGMJV-04A	60	0.40	GDA20
Yaskawa Σ5	SGMJV-06A	60	0.60	GDA20
Yaskawa Σ5	SGMJV-08A	80	0.75	GDB20
Yaskawa Σ7	SGM7A-04A	60	0.40	GDA20
Yaskawa Σ7	SGM7A-06A	60	0.60	GDA20
Yaskawa Σ7	SGM7A-08A	80	0.75	GDB20
Yaskawa Σ7	SGM7A-10A	80	1.00	GDB20
Yaskawa Σ7	SGM7J-04A	60	0.40	GDA20
Yaskawa Σ7	SGM7J-06A	60	0.60	GDA20
Yaskawa Σ7	SGM7J-08A	80	0.75	GDB20
Yaskawa Σ7	SGM7G-03A	90	0.30	GDE20
Yaskawa Σ7	SGM7G-05A	90	0.45	GDD20

* Recommended Motor Interface with shortest lead time

GTB80

Globoidal (Roller Gear) Servo Positioner | MI Adapter Selection

□ = Motor Frame Size

Ratio 60:1

Gear Drive: High Inertia Applications

Make / Series	Model	□ mm	kW	MI	Motor Shaft Bushing
Allen Bradley VPL	VPL-B0753	80	0.81	HGD24*	○
Allen Bradley VPL	VPL-B1002	100	1.12	HGG26	○
FANUC α	αiS2/5000	90	0.75	HGB23	○
FANUC α	αiS2/6000	90	1.00	HGB23	○
FANUC α	αiF1/5000	90	0.50	HGB23	○
FANUC α	αiF2/5000	90	0.75	HGB23	○
FANUC β	βiS2/4000	90	0.50	HGB23	○
Mitsubishi J3	HF-KP73	80	0.75	HGA20	-
Mitsubishi J3	HF-MP73	80	0.75	HGA20	-
Mitsubishi J4	HG-KR73	80	0.75	HGA20	-
Mitsubishi J4	HG-MR73	80	0.75	HGA20	-
Panasonic A5	MSMD08	80	0.75	HGC20	-
Panasonic A5	MSME08	80	0.75	HGC20	-
Panasonic A5	MHMD08	80	0.75	HGC20	-
Panasonic A6	MHMF08	80	0.75	HGC20	-
Panasonic A6	MHMF09	80	1.00	HGC20	-
Panasonic A6	MSMF08	80	0.75	HGC20	-
Panasonic A6	MSMF09	80	1.00	HGC20	-
Sanyo R2	R2AA08075F	80	0.75	HGA22	○
Sanyo R2	R2AAB8075F	86	0.75	HGB22	○
Sanyo R2	R2AAB8100F	86	1.00	HGB22	○
Sanyo R2	R2AAB8100H	86	1.00	HGB22	○
Yaskawa Σ5	SGMAV-08A	80	0.75	HGA20	-
Yaskawa Σ5	SGMAV-10A	80	1.00	HGA20	-
Yaskawa Σ5	SGMJV-08A	80	0.75	HGA20	-
Yaskawa Σ5	SGMGV-03A	90	0.30	HGB21	○
Yaskawa Σ5	SGMGV-05A	90	0.45	HGB22	○
Yaskawa Σ7	SGM7A-08A	80	0.75	HGA20	-
Yaskawa Σ7	SGM7A-10A	80	1.00	HGA20	-
Yaskawa Σ7	SGM7J-08A	80	0.75	HGA20	-
Yaskawa Σ7	SGM7G-03A	90	0.30	HGB22	○
Yaskawa Σ7	SGM7G-05A	90	0.45	HGB22	○

* Recommended Motor Interface with shortest lead time

Ratio 20:1

Direct Drive: Zero Backlash Precision Applications

Make / Series	Model	□ mm	kW	MI
Allen Bradley VPL	VPL-B1002	100	1.12	HDP20*
FANUC α	αiS2/5000	90	0.75	HDL20
FANUC α	αiS2/6000	90	1.00	HDL20
FANUC α	αiF1/5000	90	0.50	HDL20
FANUC α	αiF2/5000	90	0.75	HDL20
FANUC β	βiS2/4000	90	0.50	HDL20
Mitsubishi J3	HF-KP73	80	0.75	HDA20
Mitsubishi J3	HF-MP73	80	0.75	HDA20
Mitsubishi J4	HG-KR73	80	0.75	HDA20
Mitsubishi J4	HG-MR73	80	0.75	HDA20
Panasonic A5	MSMD08	80	0.75	HDE20
Panasonic A5	MSME08	80	0.75	HDE20
Panasonic A5	MSME10	100	1.00	HDF20
Panasonic A5	MSME15	100	1.50	HDG20
Panasonic A5	MSME20	100	2.00	HDG20
Panasonic A5	MHMD08	80	0.75	HDE20
Panasonic A6	MHMF08	80	0.75	HDE20
Panasonic A6	MHMF09	80	1.00	HDE20
Panasonic A6	MSMF08	80	0.75	HDE20
Panasonic A6	MSMF09	80	1.00	HDE20
Panasonic A6	MSMF10	100	1.00	HDF20
Panasonic A6	MSMF15	100	1.50	HDG20
Panasonic A6	MSMF20	100	2.00	HDG20
Sanyo R2	R2AA08075F	80	0.75	HDH20
Sanyo R2	R2AAB8075F	86	0.75	HDC20
Sanyo R2	R2AAB8100F	86	1.00	HDJ20
Sanyo R2	R2AAB8100H	86	1.00	HDC20
Sanyo R2	R2AA10075F	100	0.75	HDK20
Sanyo R2	R2AA10100F	100	1.00	HDK20
Sanyo Q1	Q1AA10100D	100	1.00	HDK20
Sanyo Q1	Q1AA10150D	100	1.50	HDK20
Sanyo Q1	Q1AA10200D	100	2.00	HDK20
Yaskawa Σ5	SGMAV-08A	80	0.75	HDA20
Yaskawa Σ5	SGMAV-10A	80	1.00	HDA20
Yaskawa Σ5	SGMGV-03A	90	0.30	HDB20
Yaskawa Σ5	SGMGV-05A	90	0.45	HDC20
Yaskawa Σ5	SGMJV-08A	80	0.75	HDA20
Yaskawa Σ5	SGMSV-10A	100	1.00	HDD20
Yaskawa Σ5	SGMSV-15A	100	1.50	HDD20
Yaskawa Σ5	SGMSV-20A	100	2.00	HDD20
Yaskawa Σ5	SGMSV-25A	100	2.50	HDD20
Yaskawa Σ7	SGM7A-08A	80	0.75	HDA20
Yaskawa Σ7	SGM7A-10A	80	1.00	HDA20
Yaskawa Σ7	SGM7A-15A	100	1.50	HDD20
Yaskawa Σ7	SGM7A-20A	100	2.00	HDD20
Yaskawa Σ7	SGM7A-25A	100	2.50	HDD20
Yaskawa Σ7	SGM7G-03A	90	0.30	HDC20
Yaskawa Σ7	SGM7G-05A	90	0.45	HDC20
Yaskawa Σ7	SGM7J-08A	80	0.75	HDA20

* Recommended Motor Interface with shortest lead time

□ = Motor Frame Size

Globoidal (Roller Gear) Servo Positioner | MI Adapter Selection

Ratio 60:1

Gear Drive: High Inertia Applications

Ratio 20:1

Direct Drive: Zero Backlash Precision Applications

Make / Series	Model	□ mm	kW	MI	Motor Shaft Bushing
Allen Bradley VPL	VPL-B1153	100	1.83	JGE27*	○
Allen Bradley VPL	VPL-B1303	130	2.82	JGG20	○
FANUC α	αiF2/5000	90	0.75	JGB25	○
FANUC α	αiF4/4000	130	1.40	JGA21	○
FANUC α	αiF8/3000	130	1.60	JGA21	○
FANUC α	αiS2/5000	90	0.75	JGB25	○
FANUC α	αiS2/6000	90	1.00	JGB25	○
FANUC α	αiS8/4000	130	2.50	JGA21	○
FANUC β	βiS2/4000	90	0.50	JGB25	○
FANUC β	βiS8/3000	130	1.20	JGA21	○
FANUC β	βiS12/2000	130	1.40	JGA20	-
FANUC β	βiS12/3000	130	1.80	JGA20	-
Mitsubishi J3	HF-SP51	130	0.50	JGA20	-
Mitsubishi J3	HF-SP52	130	0.50	JGA20	-
Mitsubishi J3	HF-SP81	130	0.85	JGA20	-
Mitsubishi J3	HF-SP102	130	1.00	JGA20	-
Mitsubishi J3	HF-SP152	130	1.50	JGA20	-
Mitsubishi J4	HG-SR51	130	0.50	JGA20	-
Mitsubishi J4	HG-SR52	130	0.50	JGA20	-
Mitsubishi J4	HG-SR81	130	0.85	JGA20	-
Mitsubishi J4	HG-SR102	130	1.00	JGA20	-
Mitsubishi J4	HG-SR152	130	1.50	JGA20	-
Panasonic A5	MDME102	130	1.00	JGA22	○
Panasonic A5	MDME152	130	1.50	JGA22	○
Panasonic A5	MDME202	130	2.00	JGA22	○
Panasonic A6	MDMF102	130	1.00	JGA22	○
Panasonic A6	MDMF152	130	1.50	JGA22	○
Panasonic A6	MDMF202	130	2.00	JGA22	○
Sanyo R2	R2AA13050D	130	0.55	JGA22	○
Sanyo R2	R2AA13050H	130	0.55	JGA22	○
Sanyo R2	R2AA13120B	130	1.20	JGA22	○
Sanyo R2	R2AA13120L	130	1.20	JGA22	○
Sanyo R2	R2AA13120D	130	1.20	JGA22	○
Sanyo R2	R2AA13180H	130	1.80	JGA22	○
Sanyo R2	R2AA13180D	130	1.80	JGA22	○
Yaskawa Σ5	SGMGV-03A	90	0.30	JGB23	○
Yaskawa Σ5	SGMGV-05A	90	0.45	JGB24	○
Yaskawa Σ5	SGMGV-09A	130	0.85	JGA21	○
Yaskawa Σ5	SGMGV-13A	130	1.30	JGA22	○
Yaskawa Σ5	SGMGV-20A	130	1.80	JGA20	-
Yaskawa Σ5	SGMSV-10A	100	1.00	JGC20	-
Yaskawa Σ5	SGMSV-15A	100	1.50	JGC20	-
Yaskawa Σ5	SGMSV-20A	100	2.00	JGC20	-
Yaskawa Σ5	SGMSV-25A	100	2.50	JGC20	-
Yaskawa Σ7	SGM7A-15A	100	1.50	JGC20	-
Yaskawa Σ7	SGM7A-20A	100	2.00	JGC20	-
Yaskawa Σ7	SGM7A-25A	100	2.50	JGC20	-
Yaskawa Σ7	SGM7G-03A	90	0.30	JGB24	○
Yaskawa Σ7	SGM7G-05A	90	0.45	JGB24	○
Yaskawa Σ7	SGM7G-09A	130	0.85	JGA20	-
Yaskawa Σ7	SGM7G-13A	130	1.30	JGA20	-
Yaskawa Σ7	SGM7G-20A	130	1.80	JGA20	-

Make / Series	Model	□ mm	kW	MI
Allen Bradley VPL	VPL-B1153	100	1.75	JDG20*
Allen Bradley VPL	VPL-B1304	130	2.82	JDH20
FANUC α	αiS8/4000	130	2.50	JDA20
FANUC α	αiS12/4000	130	2.70	JDC20
FANUC α	αiF4/4000	130	1.40	JDA20
FANUC α	αiF8/3000	130	1.60	JDA20
FANUC β	βiS8/3000	130	1.20	JDA20
FANUC β	βiS12/2000	130	1.40	JDC20
FANUC β	βiS12/3000	130	1.80	JDC20
Mitsubishi J3	HF-SP51	130	0.50	JDC20
Mitsubishi J3	HF-SP81	130	0.85	JDC20
Mitsubishi J3	HF-SP102	130	1.00	JDC20
Mitsubishi J3	HF-SP152	130	1.50	JDC20
Mitsubishi J4	HG-SR51	130	0.50	JDC20
Mitsubishi J4	HG-SR81	130	0.85	JDC20
Mitsubishi J4	HG-SR102	130	1.00	JDC20
Mitsubishi J4	HG-SR152	130	1.50	JDC20
Panasonic A5	MDME102	130	1.00	JDB20
Panasonic A5	MDME152	130	1.50	JDB20
Panasonic A5	MDME202	130	2.00	JDB20
Panasonic A6	MDMF102	130	1.00	JDB20
Panasonic A6	MDMF152	130	1.50	JDB20
Panasonic A6	MDMF202	130	2.00	JDB20
Sanyo R2	R2AA13050D	130	0.55	JDB20
Sanyo R2	R2AA13050H	130	0.55	JDB20
Sanyo R2	R2AA13120B	130	1.20	JDB20
Sanyo R2	R2AA13120L	130	1.20	JDB20
Sanyo R2	R2AA13120D	130	1.20	JDB20
Sanyo R2	R2AA13180H	130	1.80	JDB20
Sanyo R2	R2AA13180D	130	1.80	JDB20
Sanyo Q1	Q1AA10150D	100	1.50	JDE20
Sanyo Q1	Q1AA10200D	100	2.00	JDE20
Sanyo Q1	Q1AA10250D	100	2.50	JDE20
Yaskawa Σ5	SGMGV-09A	130	0.85	JDA20
Yaskawa Σ5	SGMGV-13A	130	1.30	JDB20
Yaskawa Σ5	SGMGV-20A	130	1.80	JDC20
Yaskawa Σ5	SGMSV-15A	100	1.50	JDD20
Yaskawa Σ5	SGMSV-20A	100	2.00	JDD20
Yaskawa Σ5	SGMSV-25A	100	2.50	JDD20
Yaskawa Σ7	SGM7A-15A	100	1.50	JDD20
Yaskawa Σ7	SGM7A-20A	100	2.00	JDD20
Yaskawa Σ7	SGM7A-25A	100	2.50	JDD20
Yaskawa Σ7	SGM7G-09A	130	0.85	JDC20
Yaskawa Σ7	SGM7G-13A	130	1.30	JDC20
Yaskawa Σ7	SGM7G-20A	130	1.80	JDC20

* Recommended Motor Interface with shortest lead time

* Recommended Motor Interface with shortest lead time

GTB SERIES

Globoidal (Roller Gear) Servo Positioner | Specifications

High Torque Gear Drive: High Inertia Application

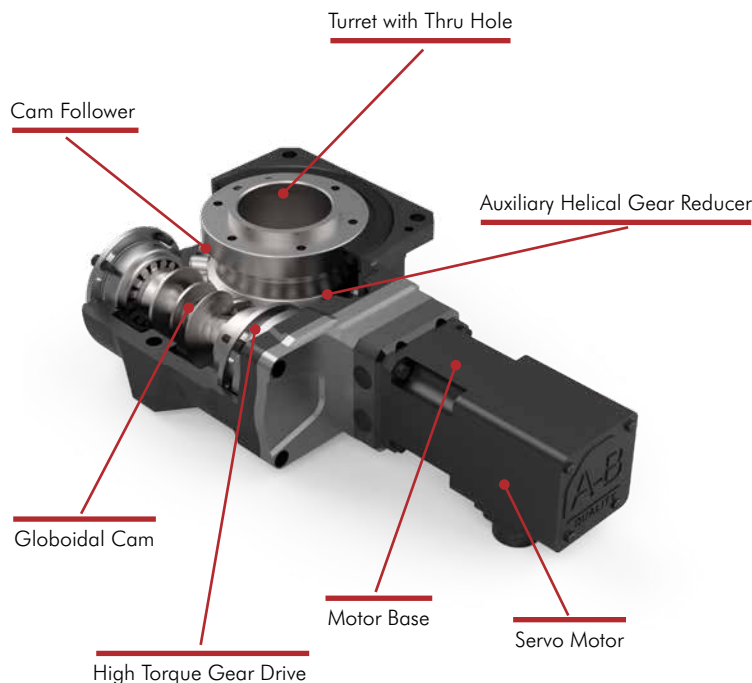

Direct Drive: Zero Backlash Precision Applications

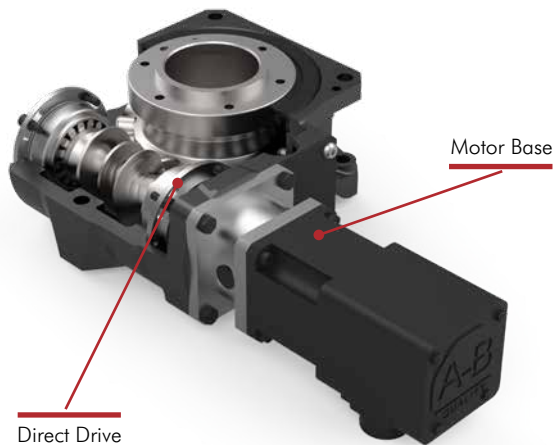

NOTE:

Motor brake must be applied for applications with gravity torque acting on output table (trunnion mounting) in the case of power loss. Follow the instruction manual for fitting and installing motor. Improper handling can cause damage or product malfunction.

General Specifications	Symbol	Units	GTB40		GTB63		GTB80		GTB100	
			Direct	Geared	Direct	Geared	Direct	Geared	Direct	Geared
Motor Coupling			Direct	Geared	Direct	Geared	Direct	Geared	Direct	Geared
Constant lead ratio			15:1	45:1	20:1	60:1	20:1	60:1	20:1	60:1
Center distance		mm	40		63		80		100	
Through hole diameter	Ø	mm	25		50		75		85	
Accuracy		arc-sec	90		60		40		40	
Allowable static torque	T _s	Nm	176		411		600		1341	
Max start / stop torque	T _u	Nm	94		210		307		880	
Allowable mean output speed	N _m	rpm	86		55		50		45	
Allowable ultimate output speed	N _u	rpm	100		70		60		50	
Allowable axial capacity on output	P _a	N	1100		1850		3632		4100	
Allowable radial capacity on output	P _r	N	740		1500		3100		3420	
Allowable moment capacity on output	P _{moment}	Nm	40		85		226		313	
Inertia moment on input axis	J	kgm ² x10 ⁻⁴	0.263	0.17	0.871	0.4	3.214	1.52	10.39	4.08
Backlash		arc-sec	0	25	0	15	0	15	0	10
Average efficiency		%	90	80	90	80	90	80	90	80
Lubrication (Maintenance Free)			Grease		Grease		Grease		Grease	
Weight		kg	3.3	3.5	5.9	6.2	12.9	14.1	24.3	25.2

GTB SERIES

Globoidal (Roller Gear) Servo Positioner | Specifications

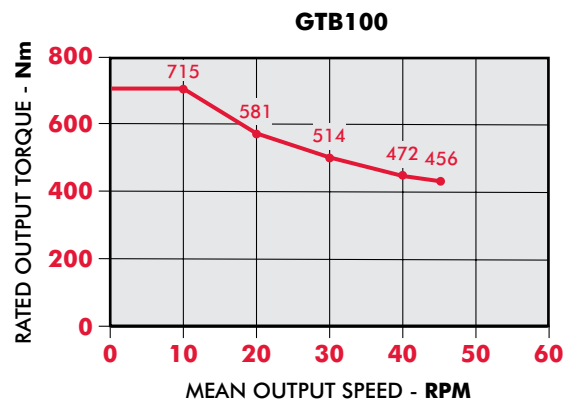
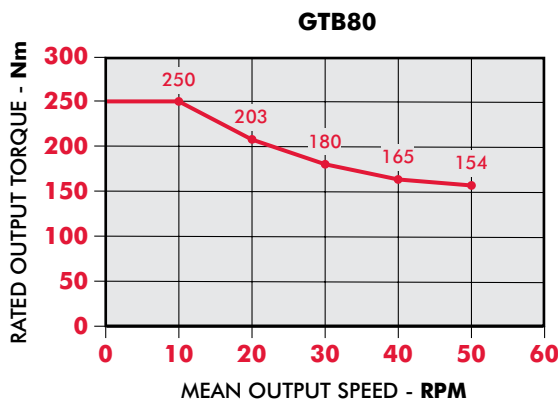
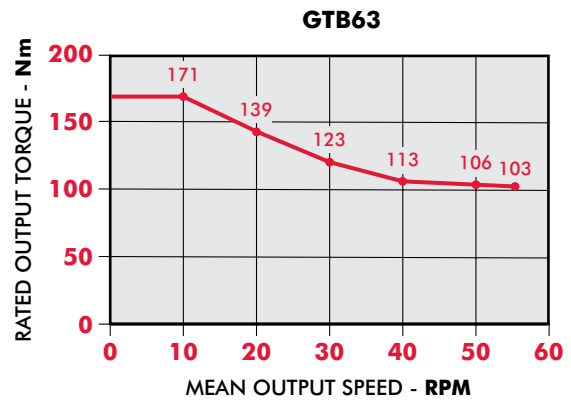
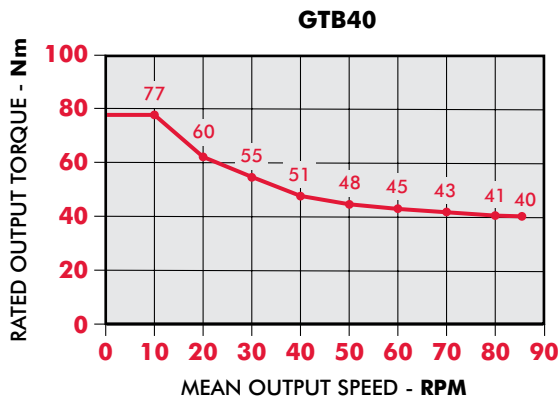

Sizing GTB Series for an Application (Contact DESTACO for sizing application support)

1. Load diagram

Check motion profile and resultant inertia torque. (Add working torque if applied).

Start and stop speed can be simplified to average speed within a segment.

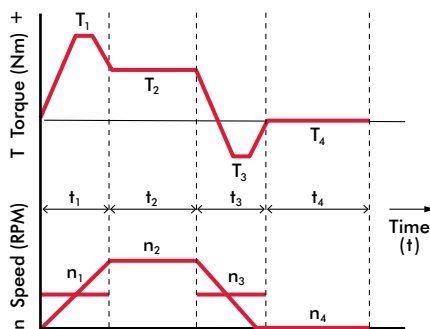

2. Check key conditions

Mean torque $T_{mean} = \sqrt{\frac{\frac{10}{3} \cdot n_1 \cdot t_1 \cdot |T_1| \cdot \frac{10}{3} + n_2 \cdot t_2 \cdot |T_2| \cdot \frac{10}{3} + \dots + n_n \cdot t_n \cdot |T_n| \cdot \frac{10}{3}}{n_1 \cdot t_1 + n_2 \cdot t_2 + \dots + n_n \cdot t_n}}$ (Nm)

Mean output speed $n_{mean} = \frac{n_1 \cdot t_1 + n_2 \cdot t_2 + \dots + n_n \cdot t_n}{t_1 + t_2 + \dots + t_n}$ (rpm)

Max output speed n_{max} (rpm)

3. Pre-selection

Choose a size that meets these criteria.

- $T_{mean} < \text{Maximum rated output torque (Nm)}$
- $n_{mean} < \text{Allowable mean output speed Nm (rpm)}$
- $n_{max} < \text{Allowable ultimate output speed Nu (rpm)}$

4. Check specifications

Start/stop torque $T_1 < \text{Maximum rated output torque (Nm)}$
 $T_3 < \text{Maximum rated output torque (Nm)}$

Operation condition factor

- Smooth without any impact or sudden load $f = 1.0$
- Normal, but occasional emergency stop $f = 1.5$
- Operation with frequent impact or sudden load $f = 3.0$

Estimated lifetime $L_h = 12000 \left(\frac{T_{op}}{f \cdot T_{mean}} \right)^{\frac{10}{3}}$ (hours)

5. Selection complete

If above values don't satisfy requirements, go back to step 2 and 3 to re-select size.

GTB40 SERIES

Globoidal (Roller Gear) Servo Positioner | Dimensions

GTB40-FG (Motor Frame Size □ = 38, 40)

Gear Drive: High Inertia applications: Ratio 45:1

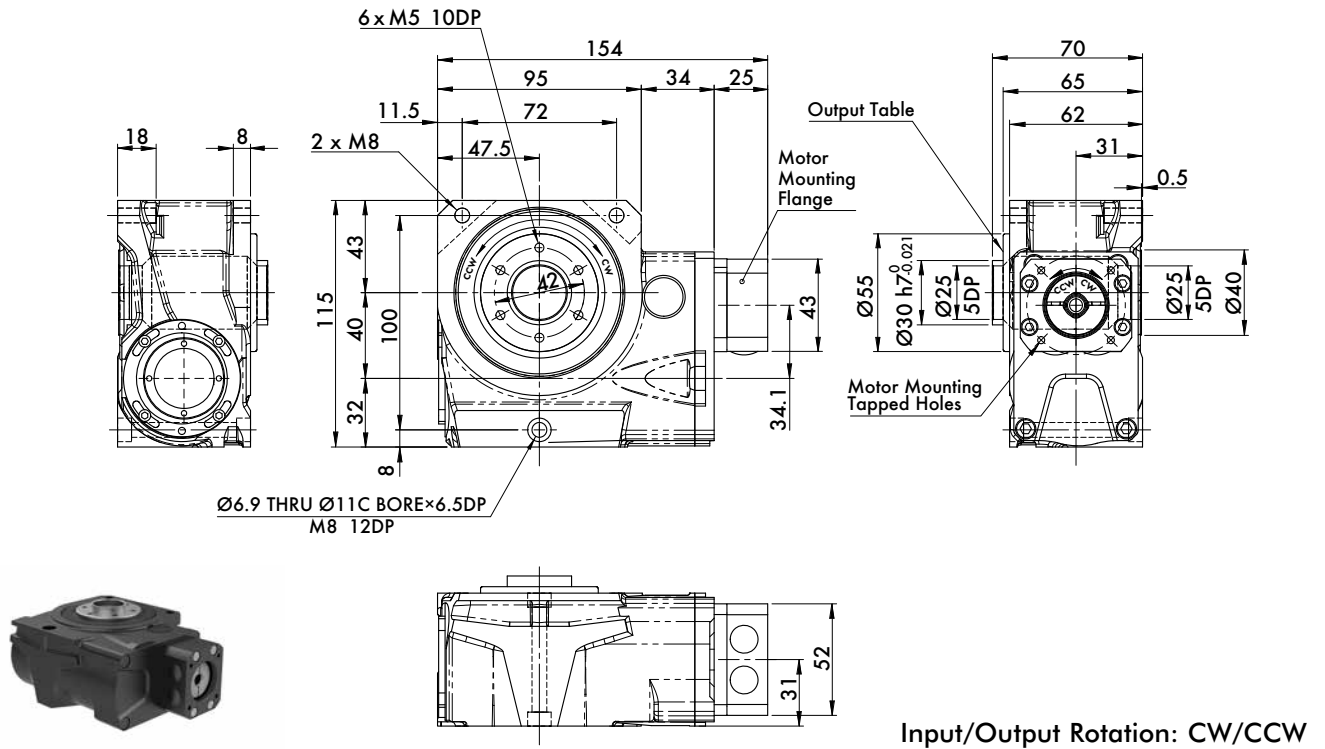

GTB40-FD (Motor Frame Size □ = 60)

Direct Drive: Zero Backlash Precision Applications: Ratio 15:1

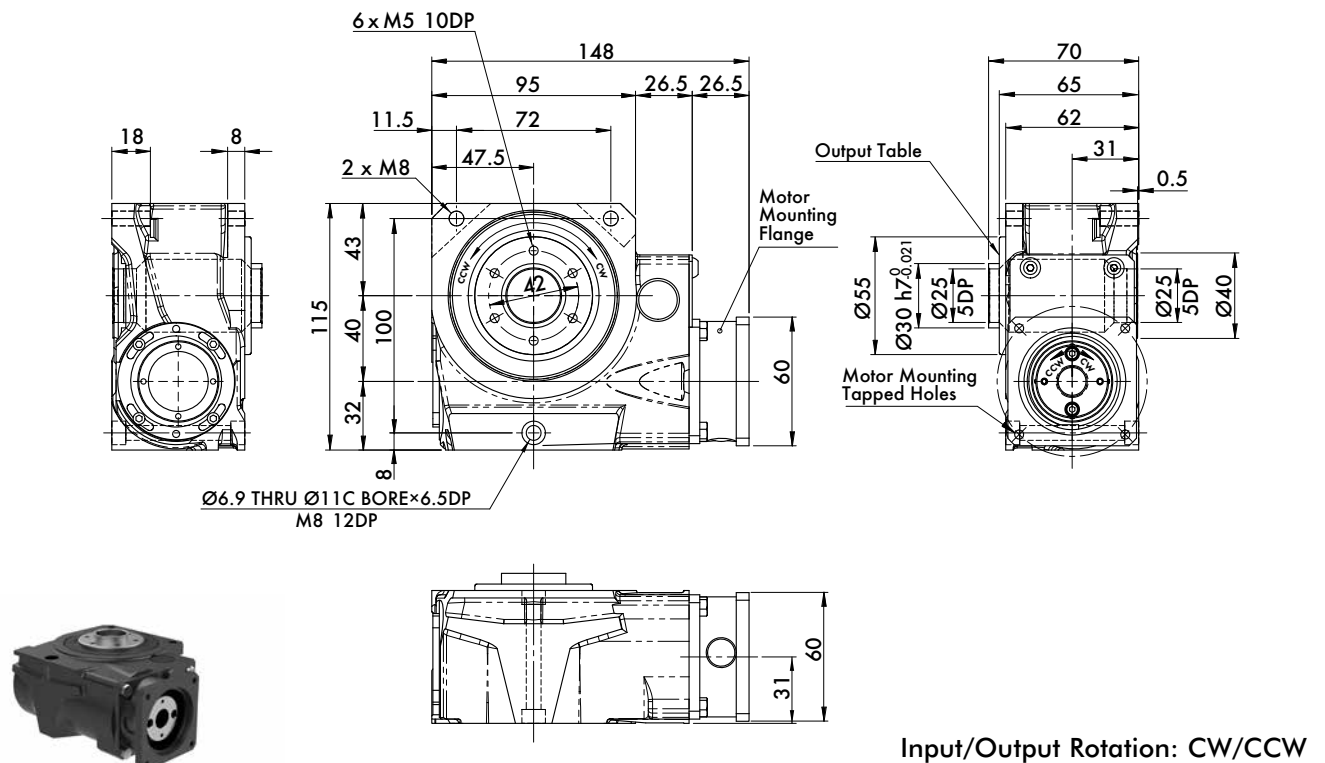

GTB40, GTB63 SERIES

Globoidal (Roller Gear) Servo Positioner | Dimensions

GTB40 Option Specifications

Dowel hole options B: Housing / T: Output Table

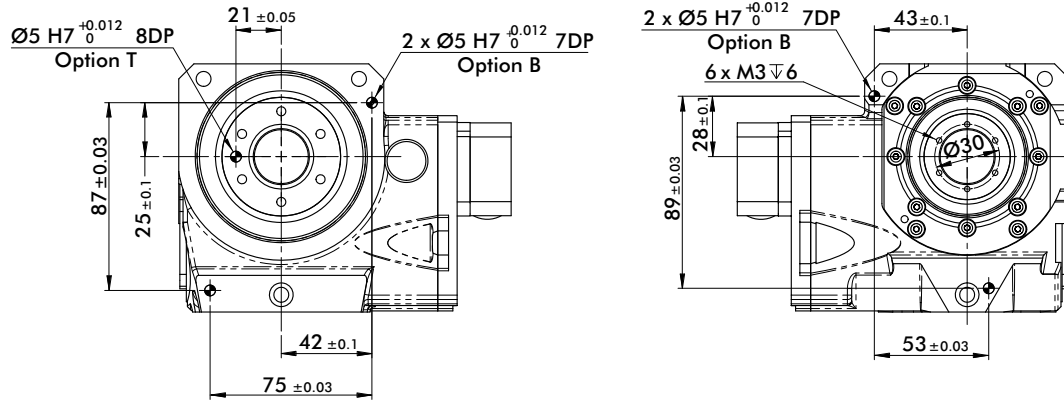

GTB-63-GG (Motor Frame Size □ = 60)

Gear Drive: High Inertia applications: Ratio 60:1

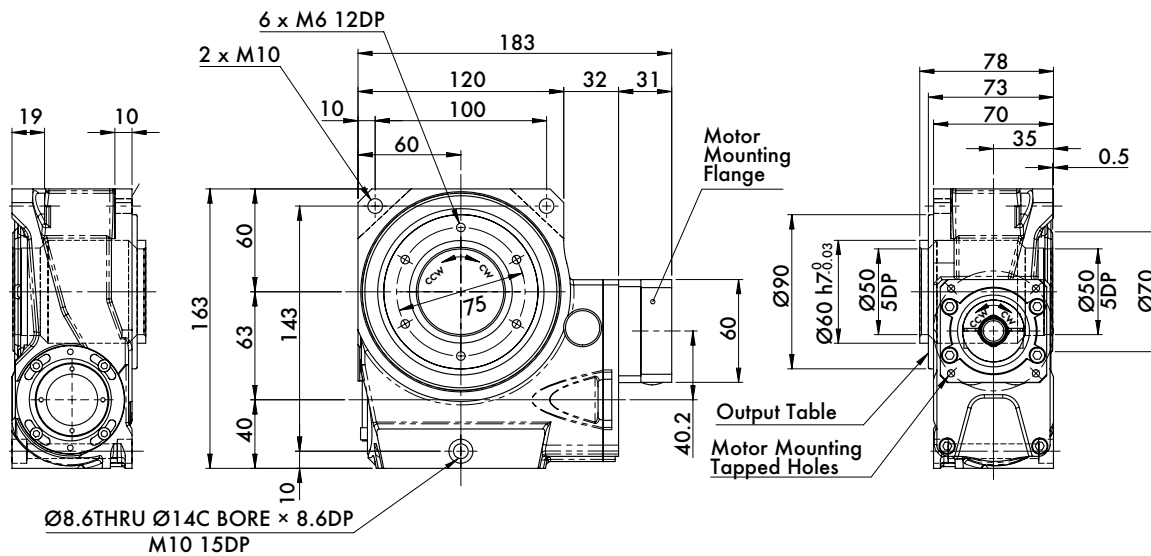

Input/Output Rotation: CW/CCW

GTB63 SERIES

Globoidal (Roller Gear) Servo Positioner | Dimensions

GTB63-GD (Motor Frame Size □ = 60)

Standard Torque Direct Drive: Ratio 1:20

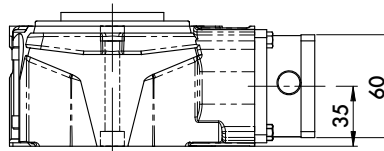
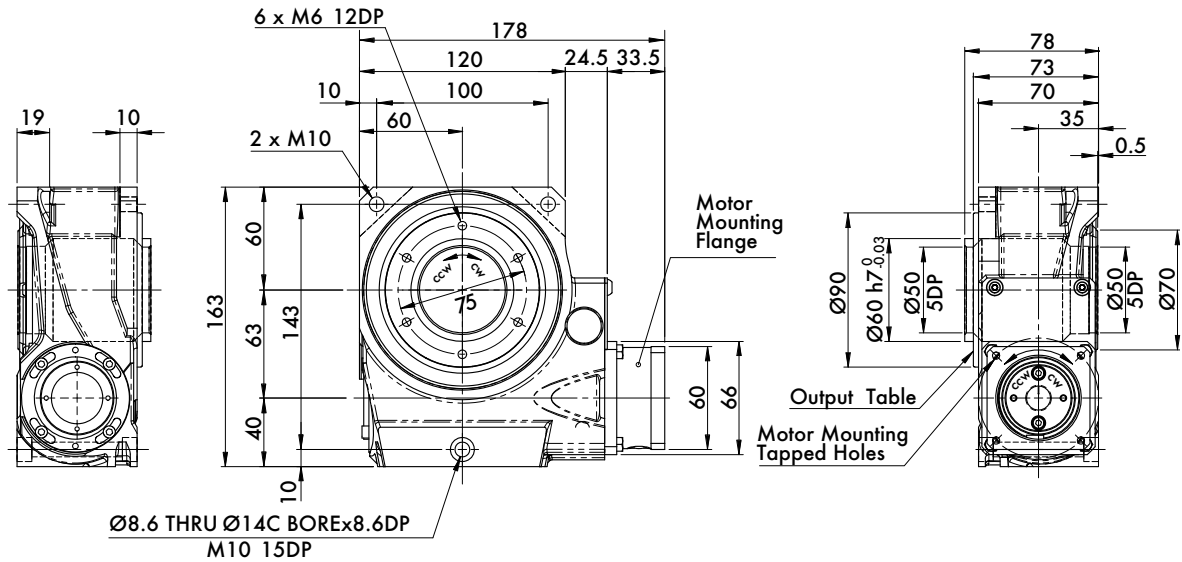

Input/Output Rotation: CW/CCW

GTB63-GD (Motor Frame Size □ = 80)

Direct Drive: Zero Backlash Precision Applications: Ratio 20:1

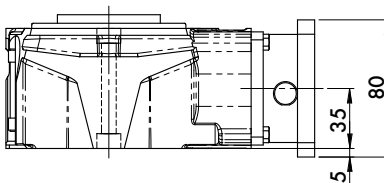
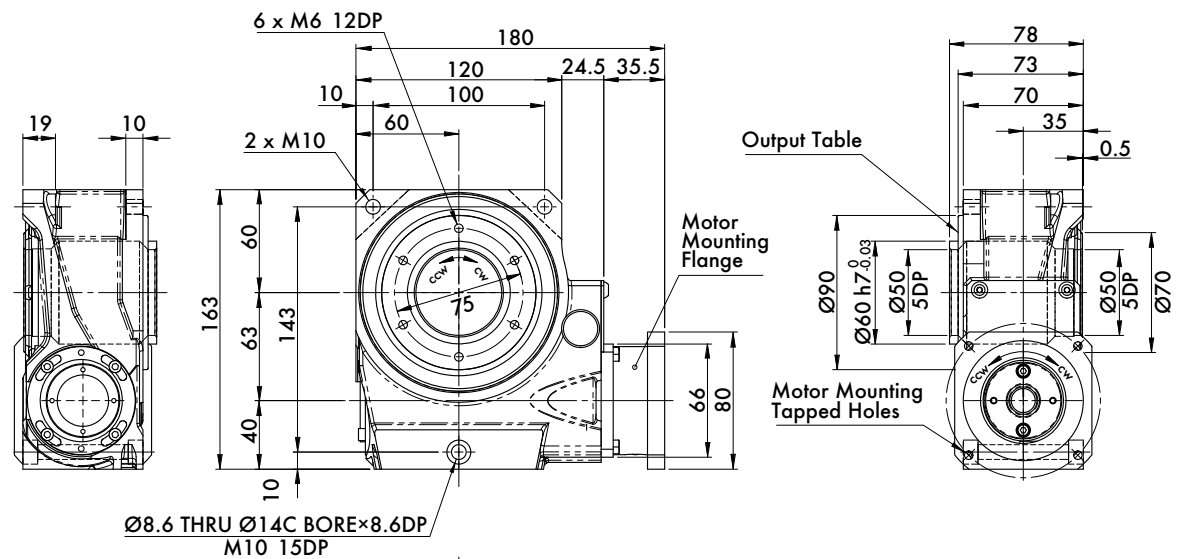

Input/Output Rotation: CW/CCW

GTB63 SERIES

Globoidal (Roller Gear) Servo Positioner | Dimensions

GTB63-GD (Motor Frame Size □ = 86, 90)

Direct Drive: Zero Backlash Precision Applications: Ratio 20:1

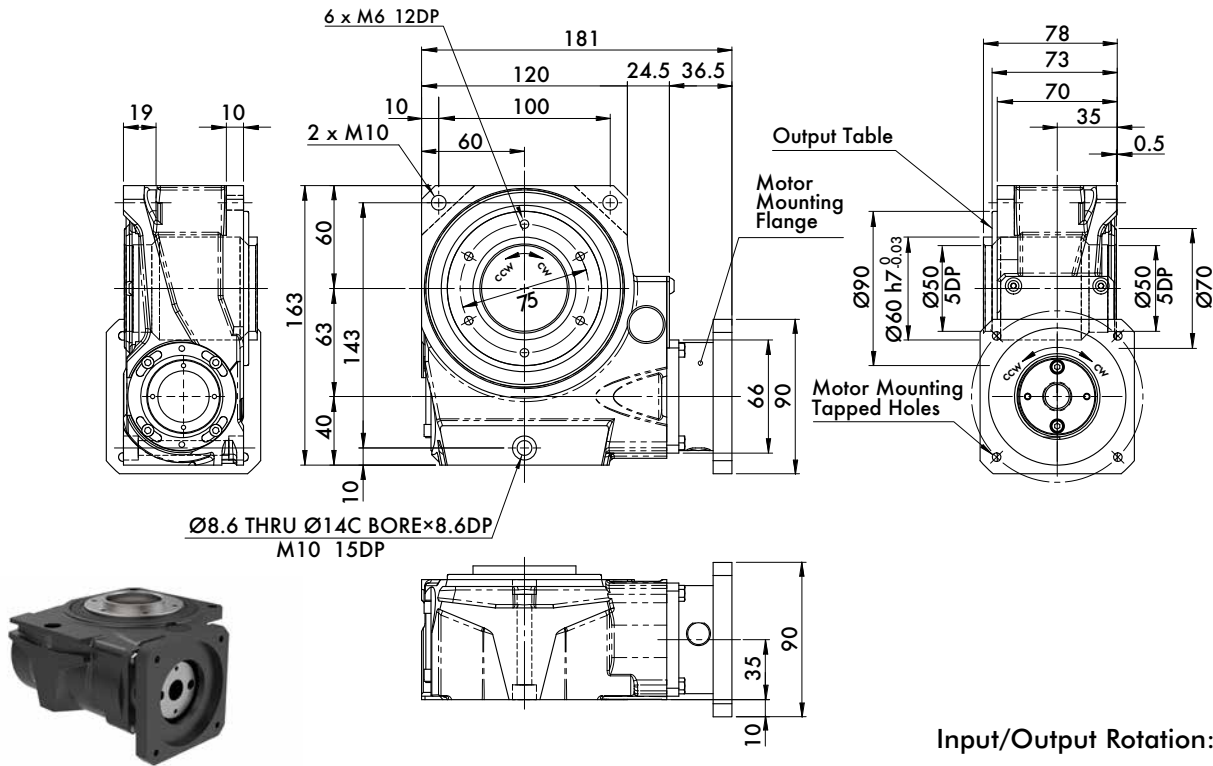

Input/Output Rotation: CW/CCW

GTB63 Option Specifications

Dowel hole options B: Housing / T: Output Table

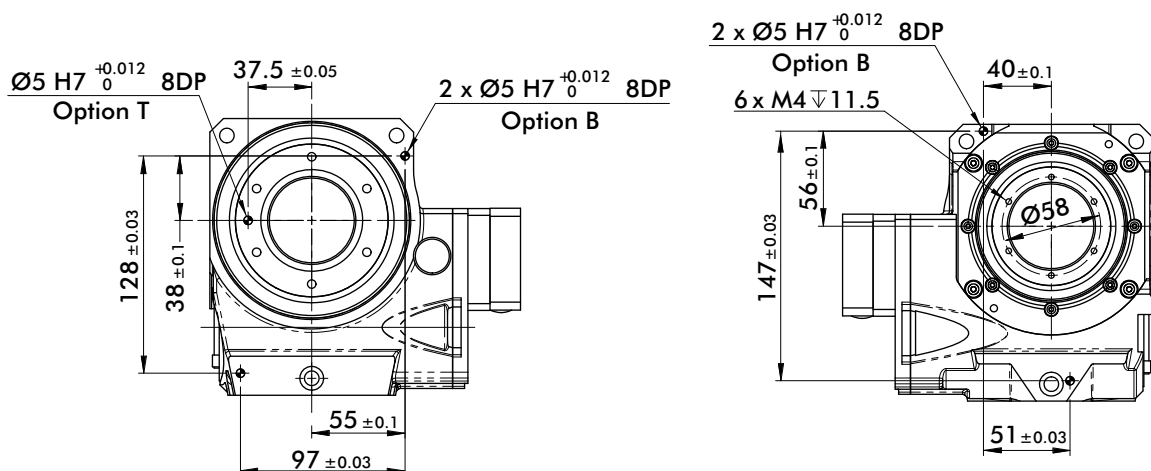

GTB80 SERIES

Globoidal (Roller Gear) Servo Positioner | Dimensions

GTB80-HG (Motor Frame Size □ = 80)

Gear Drive: High Inertia applications: Ratio 60:1

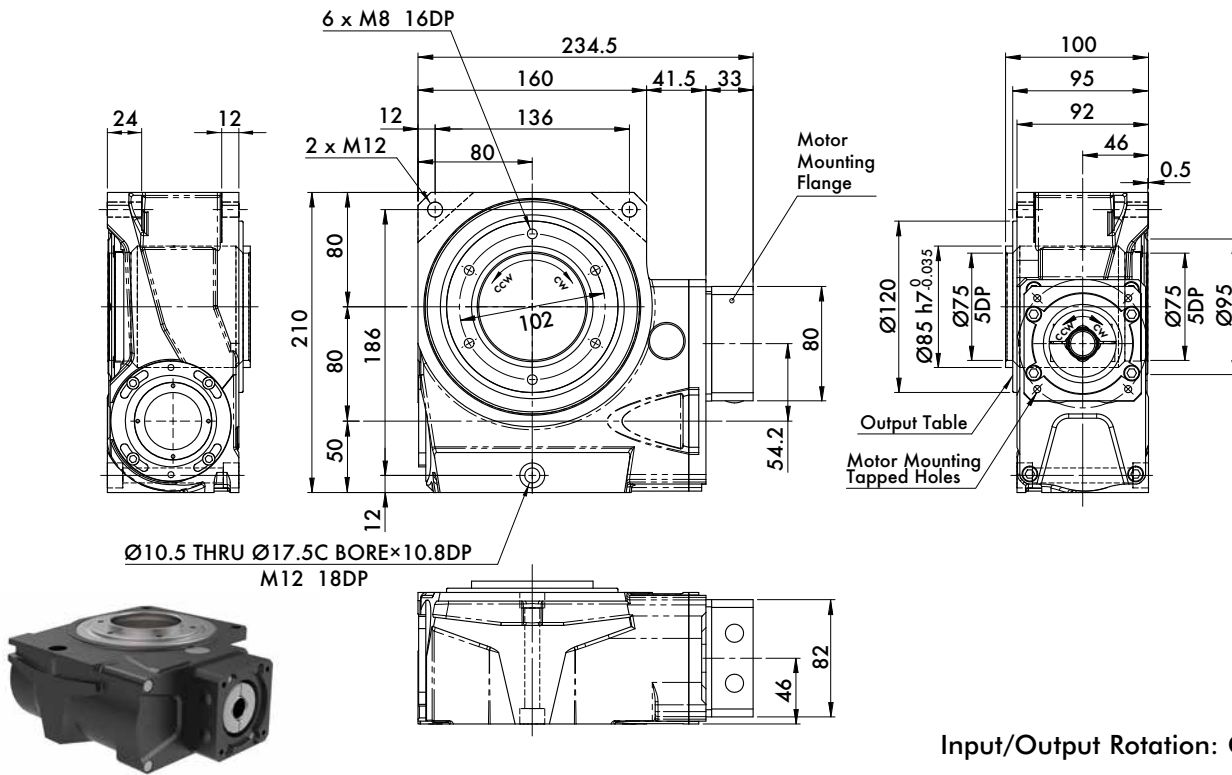

GTB80-HG (Motor Frame Size □ = 86, 90)

Gear Drive: High Inertia applications: Ratio 60:1

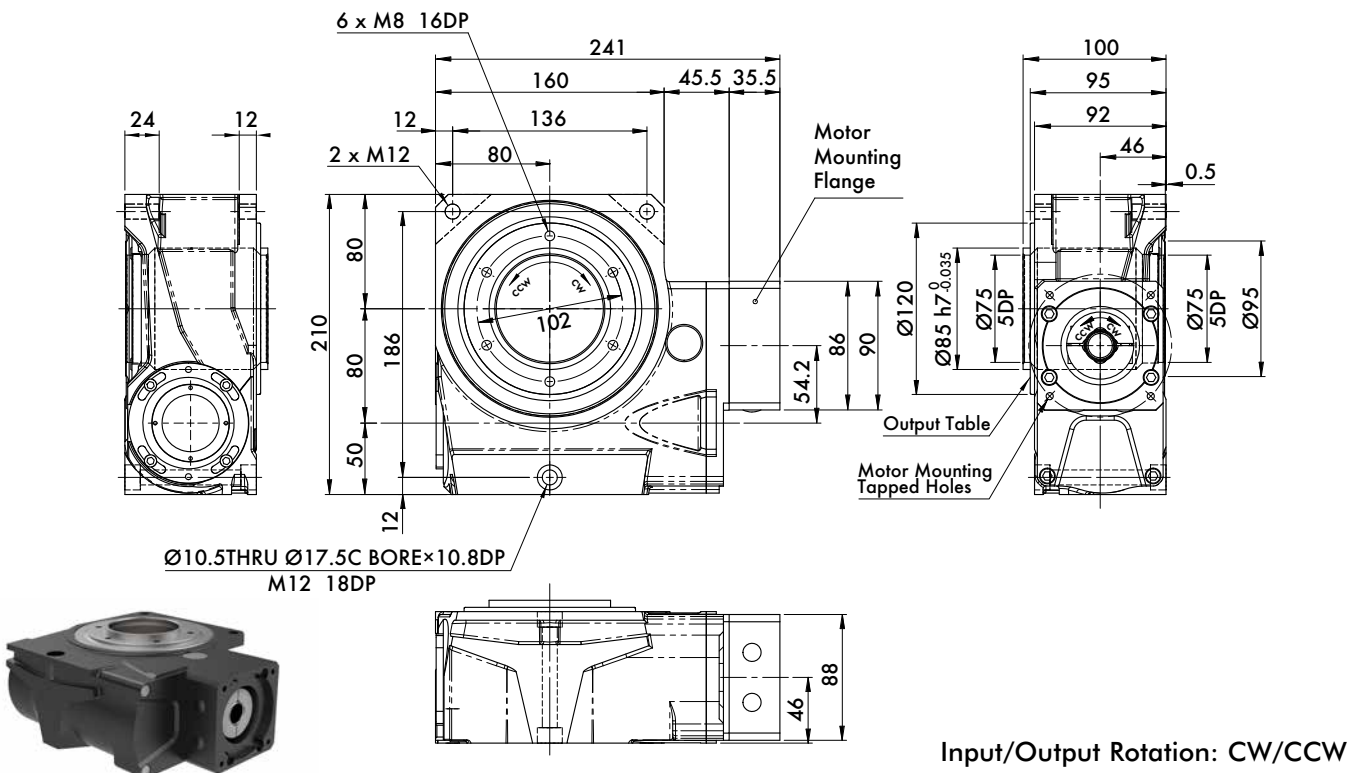

GTB80 SERIES

Globoidal (Roller Gear) Servo Positioner | Dimensions

GTB80-HD (Motor Frame Size □ = 80)

Direct Drive: Zero Backlash Precision Applications: Ratio 20:1

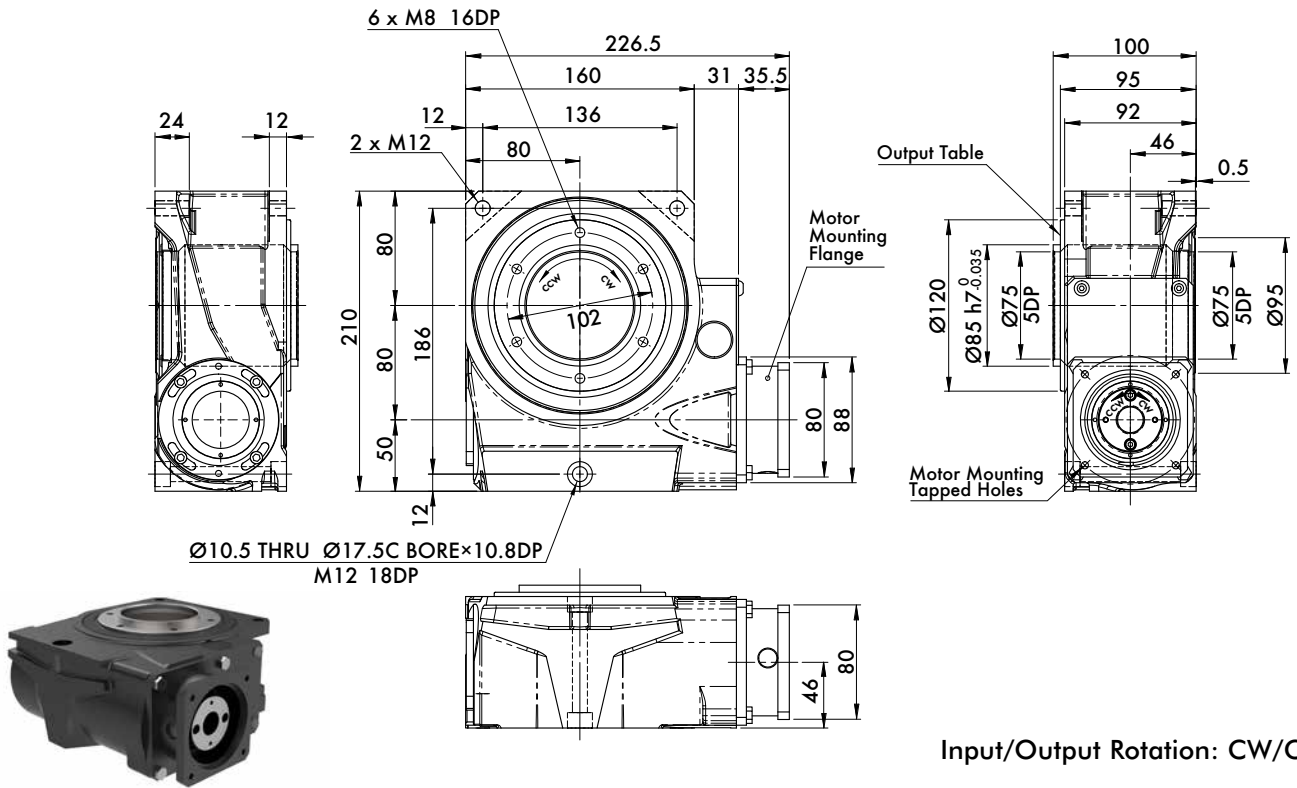

GTB80-HD (Motor Frame Size □ = 86, 90)

Direct Drive: Zero Backlash Precision Applications: Ratio 20:1

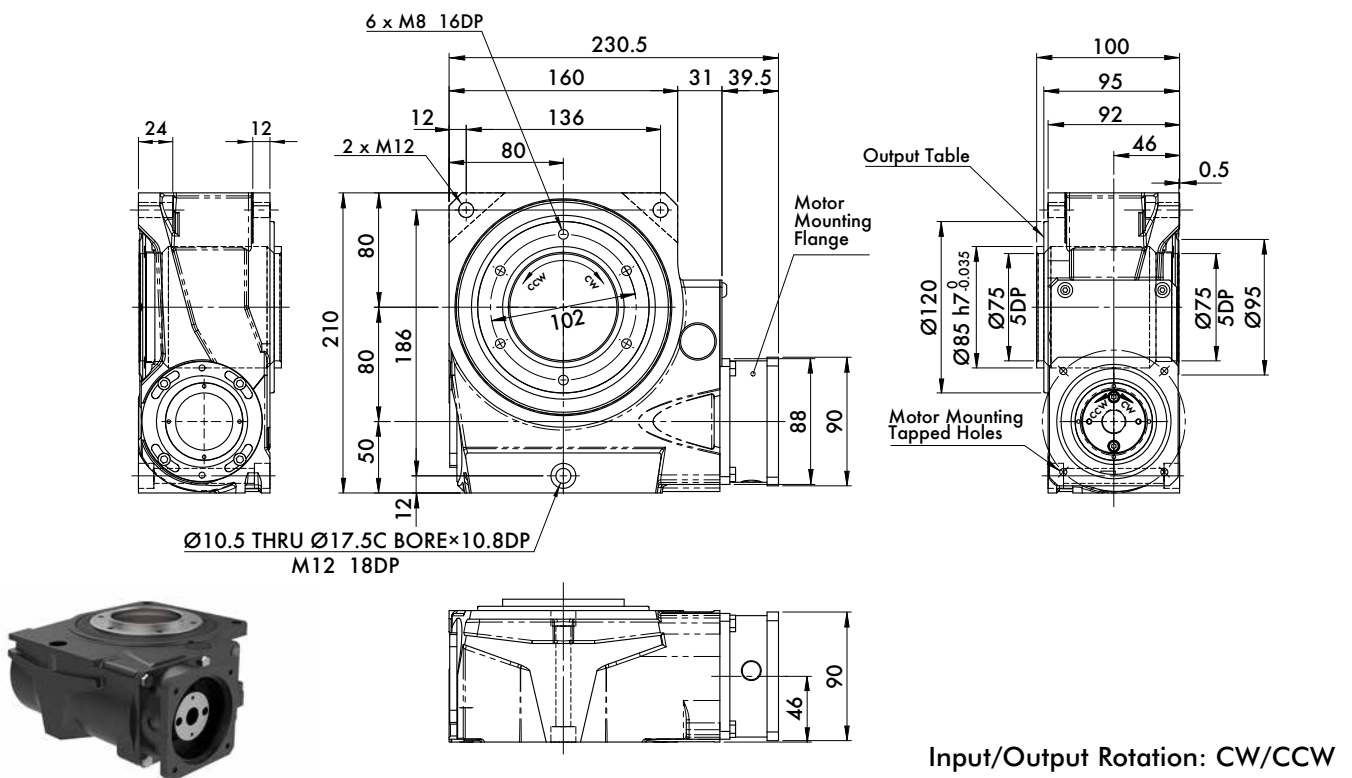

GTB80 SERIES

Globoidal (Roller Gear) Servo Positioner | Dimensions

GTB80-HD (Motor Frame Size □ = 100)

Direct Drive: Zero Backlash Precision Applications: Ratio 20:1

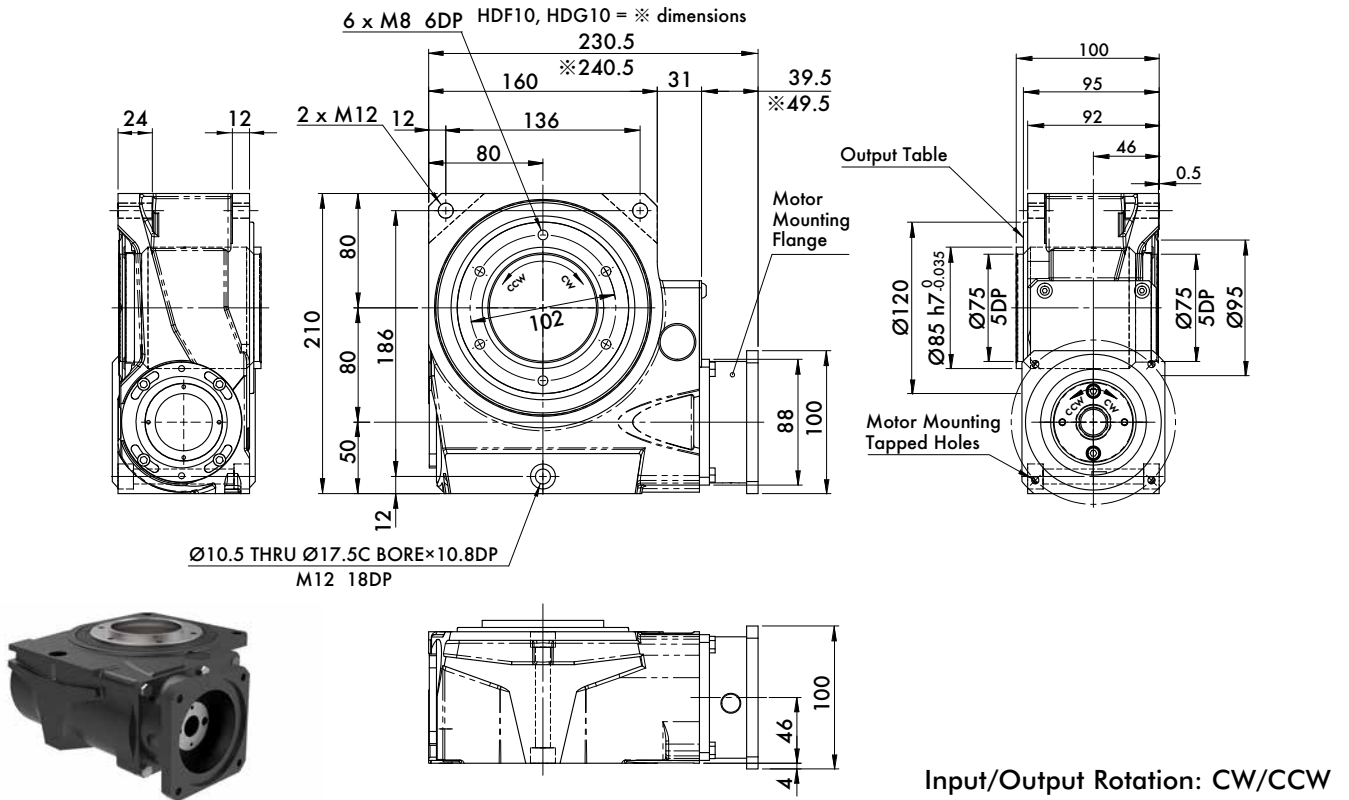

GTB80 Option Specifications

Dowel hole options B: Housing / T: Output Table

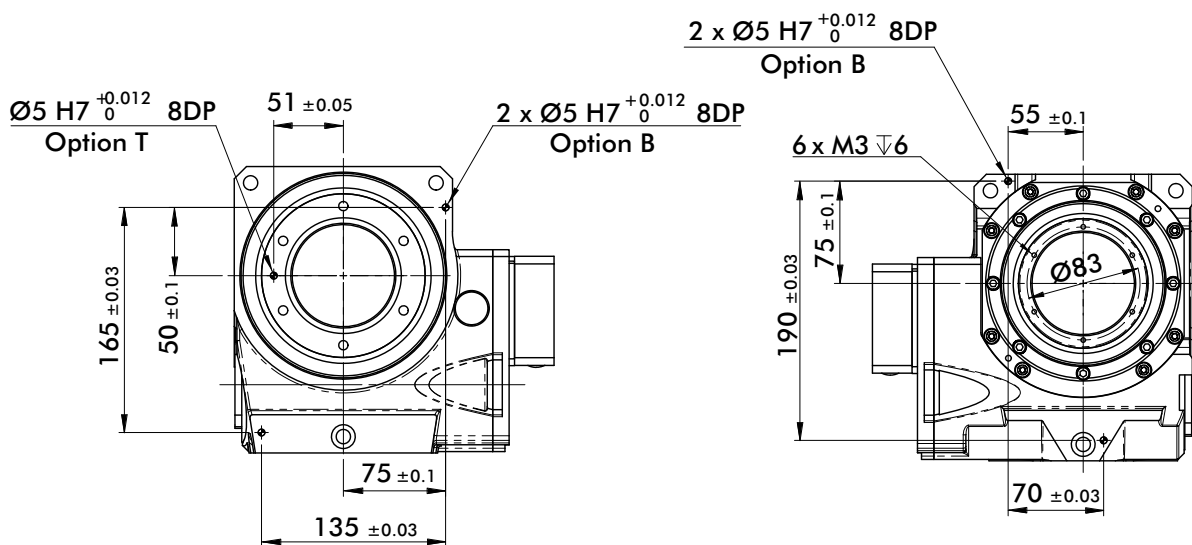

GTB100 SERIES

Globoidal (Roller Gear) Servo Positioner | Dimensions

GTB100-JG (Motor Frame Size □ = 90)

Gear Drive: High Inertia applications: Ratio 60:1

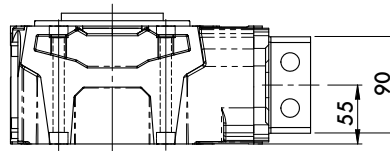
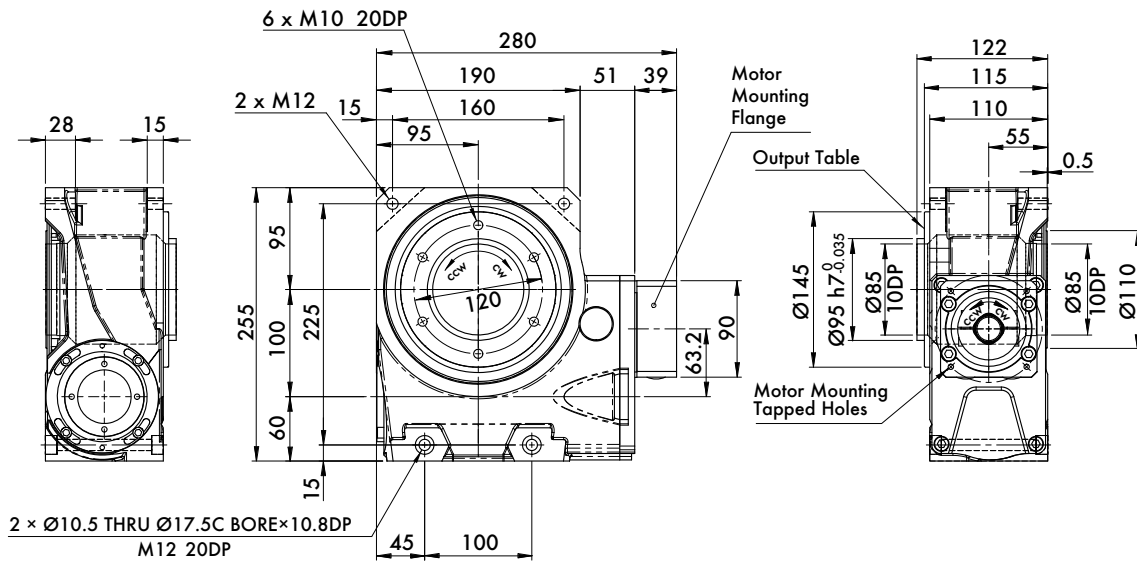

Input/Output Rotation: CW/CCW

GTB100-JG (Motor Frame Size □ = 100)

Gear Drive: High Inertia applications: Ratio 60:1

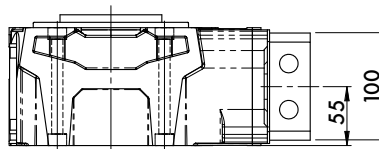
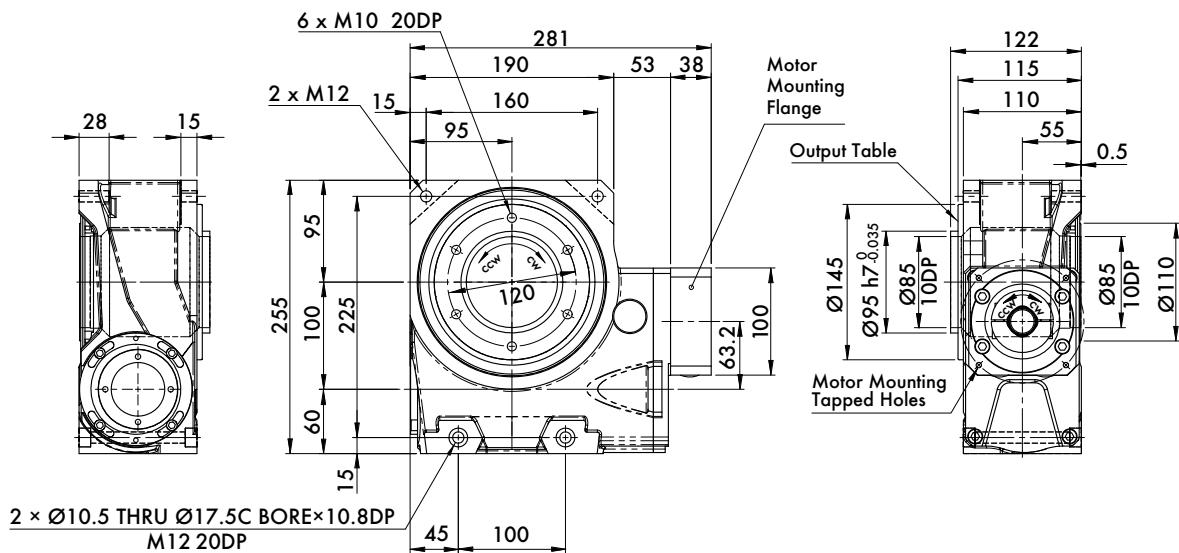

Input/Output Rotation: CW/CCW

GTB100 SERIES

Globoidal (Roller Gear) Servo Positioner | Dimensions

GTB100-JG (Motor Frame Size □ = 130)

Gear Drive: High Inertia applications: Ratio 60:1

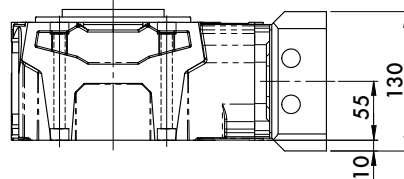
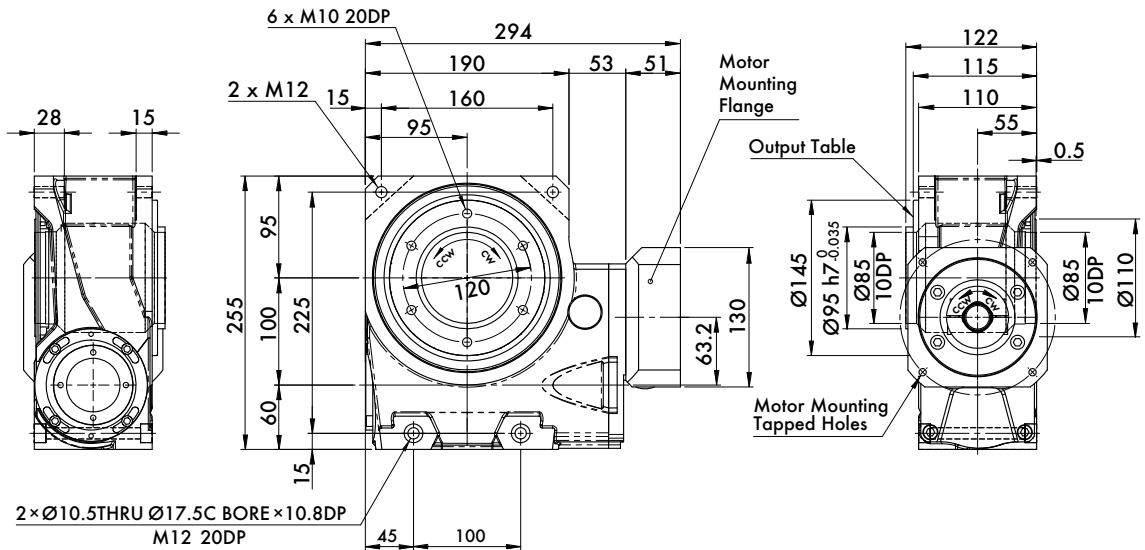

Input/Output Rotation: CW/CCW

GTB100-JD (Motor Frame Size □ = 100)

Direct Drive: Zero Backlash Precision Applications: Ratio 20:1

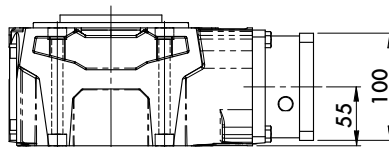
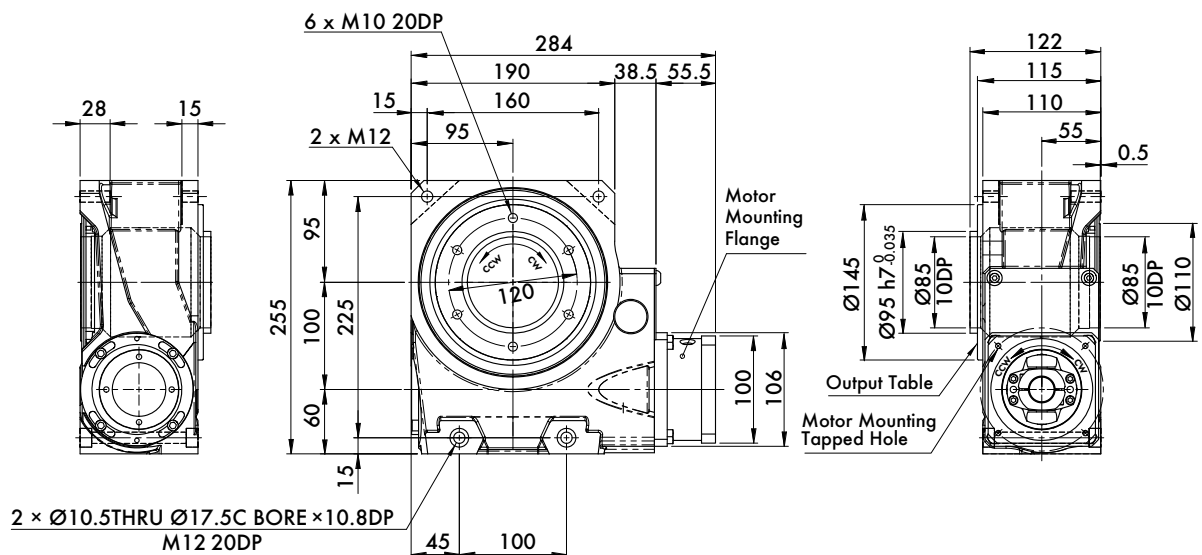

Input/Output Rotation: CW/CCW

GTB100 SERIES

Globoidal (Roller Gear) Servo Positioner | Dimensions

GTB100-JD (Motor Frame Size □ = 130)

Direct Drive: Zero Backlash Precision Applications: Ratio 20:1

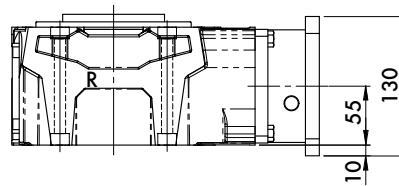
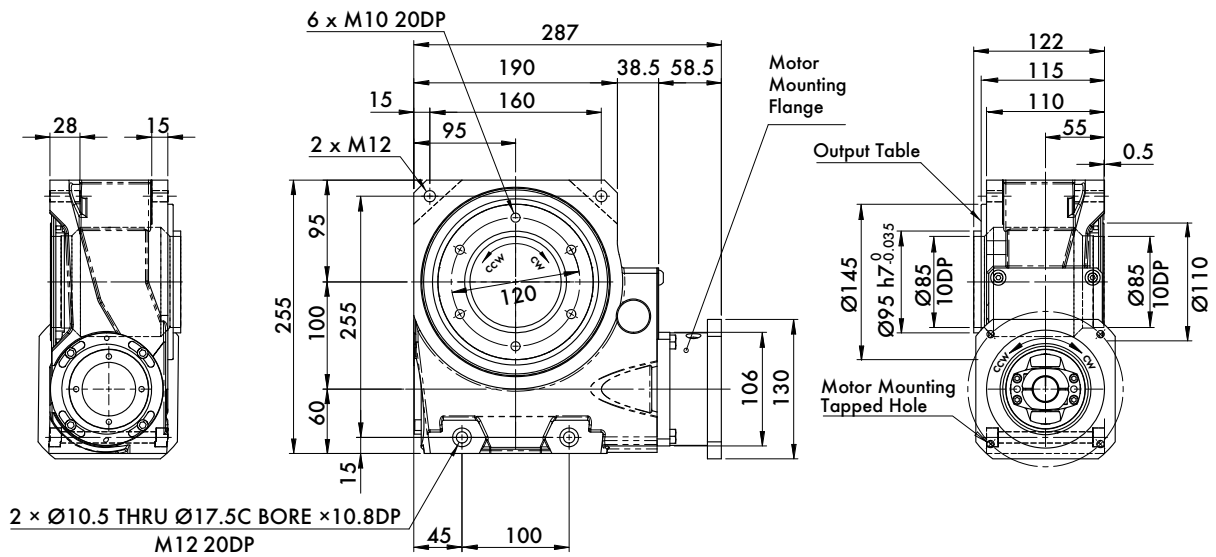

Input/Output Rotation: CW/CCW

GTB100 Option Specifications

Dowel hole options B: Housing / T: Output Table

