

8ORDM SERIES

Precision Indexing | Product Overview, Technical Specifications

| Maximum Inertia x 1000 [lb-in ²] for standard package | | | | | | | |
|---|-----------------------|-------|-------|-------|-------|-------|-------|
| Stops | Motion Time [seconds] | | | | | | |
| | 0.458 | 0.611 | 0.764 | 0.917 | 1.222 | 1.528 | 1.833 |
| 2 | 0 | 1 | 2 | 5 | 10 | 16 | 23 |
| 3 | 1 | 3 | 7 | 11 | 21 | 32 | 47 |
| 4 | 2 | 6 | 13 | 23 | 46 | 74 | 104 |
| 6 | 5 | 13 | 28 | 43 | 84 | 137 | 191 |
| 8 | 7 | 15 | 25 | 39 | 76 | 127 | 191 |
| 12 | 17 | 34 | 57 | 88 | 170 | 191 | 191 |
| 16 | 16 | 31 | 52 | 79 | 153 | 191 | 191 |
| Reducer Ratio | | | | | | | |
| | 15 | 20 | 25 | 30 | 40 | 50 | 60 |

Contact your DE-STA-CO sales representative for more information.

Features

- R180 Reducer (Ratios from 15:1 to 60:1)
 - Double Extended Worm Shaft (Input)
 - Worm Shaft Handwheel
- Double Extended Camshaft (Input Shaft)
- Center Thru Hole (70 mm / 2.76 in. Diameter)
- 1/3 hp AC Drive Package with Inverter Duty Motor and IM-pAC AC Drive (up to 60 cpm)
- Cycle Cam and Limit Switch Mounted to Camshaft
- Right Hand Cam
- Universal Mounting Capability

Optional Accessories

- 1/3 hp DC Motor
- Varipak DC Motor Control (up to 30 cpm)
- Stationary Center Post
- Dual Cam and Limit Switch
- Electric Clutch-Brake
- Left Hand Cam

Output Load Capacity (loads carried during index):

| | |
|--------------|-------------|
| Radial | 755 lbs |
| Thrust/Axial | 1,885 lbs |
| Moment | 1,885 in-lb |

Typical Application Dial Diameter:

8 in. to 28 in.

Accuracy

±44 arcsec / ±.003" at 14" Radius

Repeatability Radius

±11 arcsec / ±.0007" at 14" Radius

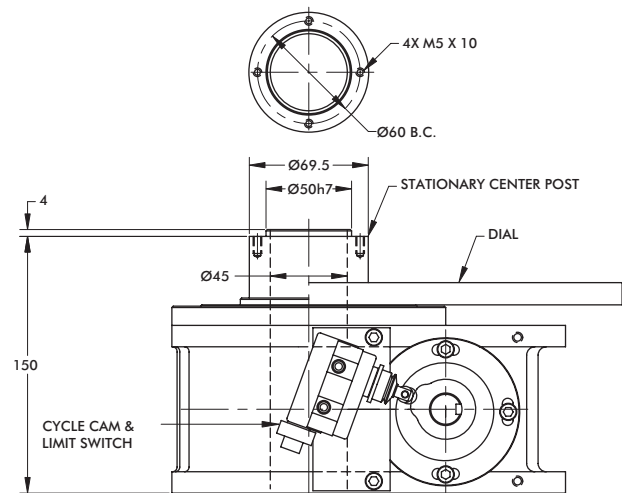

8ORDM OPTIONS



Unless otherwise noted,
all dimensions are in mm.

601RDM SERIES

Precision Indexing | Dimensions

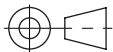
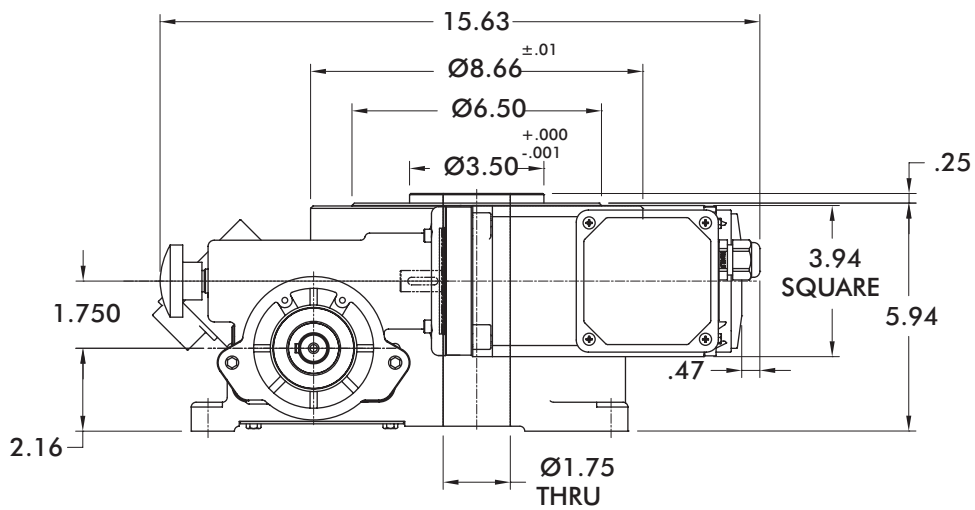
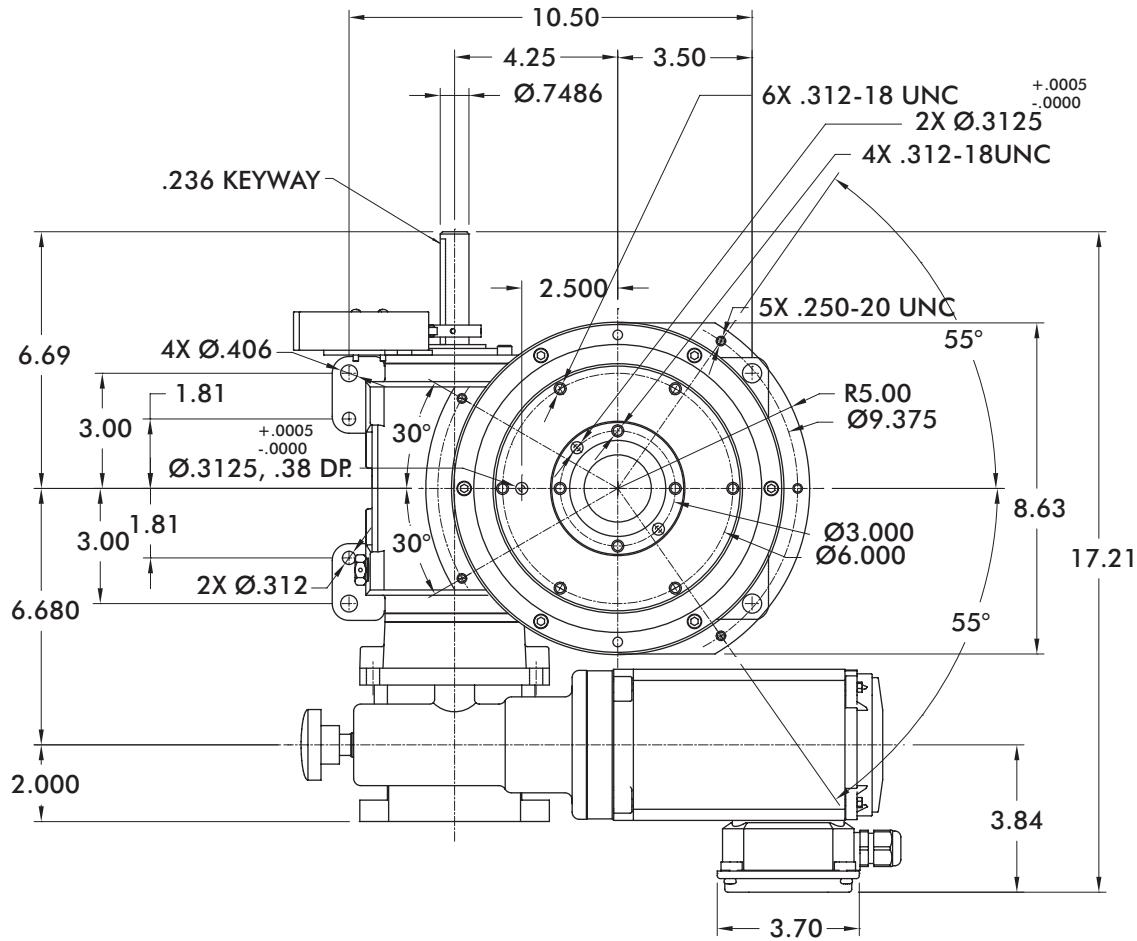

Unless otherwise noted,
all dimensions are in inches.

601RDM SERIES

Precision Indexing | Product Overview, Technical Specifications

| Maximum Inertia x 1000 [lb-in ²] for standard package | | | | | | | |
|---|-----------------------|-------|-------|-------|-------|-------|-------|
| Stops | Motion Time [seconds] | | | | | | |
| | 0.458 | 0.611 | 0.764 | 0.917 | 1.222 | 1.528 | 1.833 |
| 2 | 0 | 1 | 2 | 5 | 11 | 17 | 24 |
| 3 | 1 | 3 | 7 | 12 | 28 | 42 | 58 |
| 4 | 2 | 6 | 13 | 23 | 52 | 78 | 106 |
| 6 | 5 | 14 | 28 | 51 | 112 | 168 | 228 |
| 8 | 10 | 25 | 51 | 90 | 199 | 299 | 406 |
| 12 | 22 | 57 | 115 | 204 | 449 | 478 | 478 |
| 16 | 40 | 101 | 205 | 361 | 478 | 478 | 478 |
| Reducer Ratio | | | | | | | |
| | 15 | 20 | 25 | 30 | 40 | 50 | 60 |

Other Motions (stops and index periods) available. Contact your DE-STA-CO sales representative for more information.

Features

- R180 Reducer (Ratios from 15:1 to 60:1)
 - Double Extended Worm Shaft (Input)
 - Worm Shaft Handwheel
- Double Extended Camshaft (Input Shaft)
- Center Thru Hole (1.75 in. Diameter)
- 1/3 hp AC Drive Package with Inverter Duty Motor and IM-pAC AC Drive (up to 60 cpm)
- Cycle Cam and Limit Switch Mounted to Camshaft
- Right Hand Cam

Optional Accessories

- 1/3 hp DC Motor
- Varipak DC Motor Control (up to 30 cpm)
- Output Overload Clutch model 4.0D
 - Available Settings (in-lbs): 420, 620, 750, 1150, 1750, 2940, 4000
- Stationary Center Post
- Dual Cam and Limit Switch
- Left Hand Cam
- Relief in Dwell for shot-pin applications

Output Load Capacity (loads carried during index):

| | |
|--------------|-------------|
| Radial | 945 lbs |
| Thrust/Axial | 2,360 lbs |
| Moment | 3,305 in-lb |

Typical Application

Dial Diameter:

12 in. to 36 in.

Accuracy

±39 arcsec / ±.003" at 18" Radius

Repeatability

±10 arcsec / ±.0009" at 18" Radius

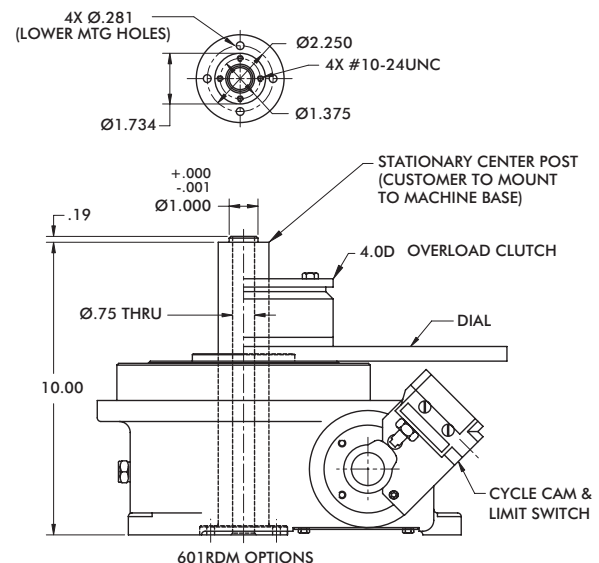

Unless otherwise noted,
all dimensions are in inches.

902RDM SERIES

Precision Indexing | Dimensions

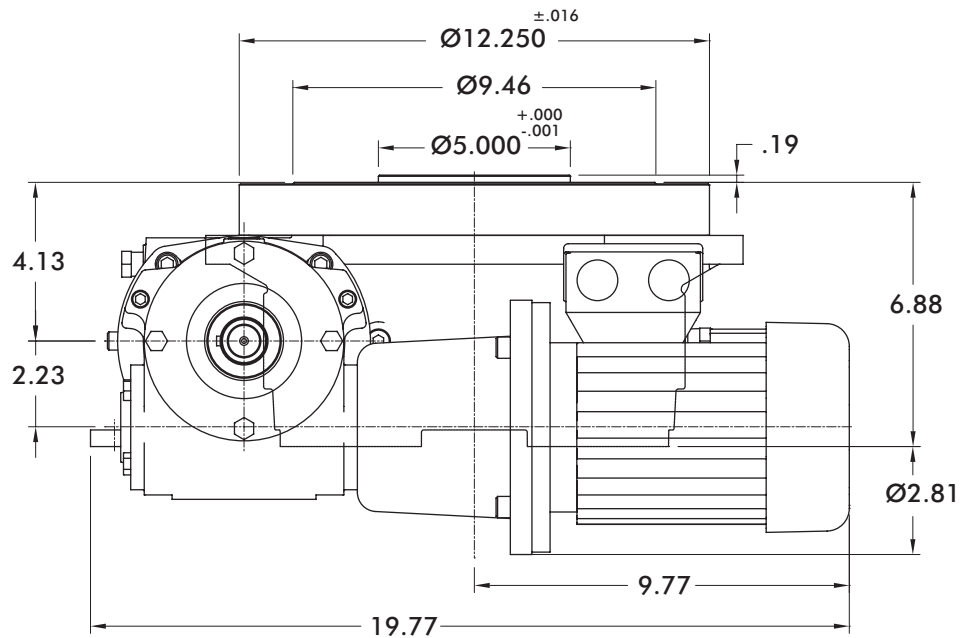
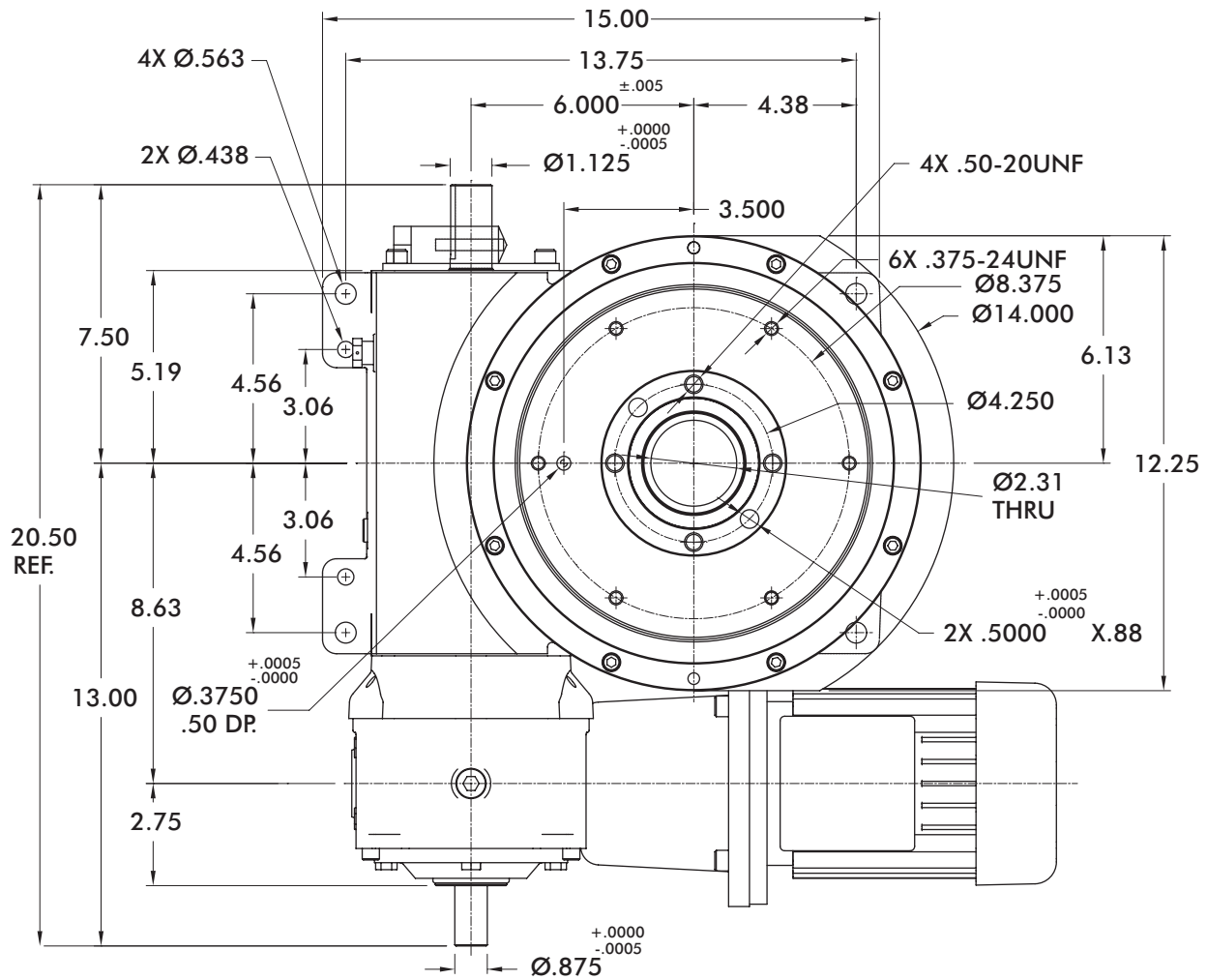

Unless otherwise noted,
all dimensions are in inches.

902RDM SERIES

Precision Indexing | Product Overview, Technical Specifications

| Maximum Inertia x 1000 [lb-in ²] for standard package | | | | | | | |
|---|-----------------------|-------|-------|-------|-------|-------|-------|
| Stops | Motion Time [seconds] | | | | | | |
| | 0.458 | 0.611 | 0.764 | 0.917 | 1.222 | 1.528 | 1.833 |
| 2 | 1 | 3 | 7 | 12 | 26 | 40 | 55 |
| 3 | 4 | 11 | 23 | 41 | 84 | 126 | 174 |
| 4 | 8 | 20 | 41 | 73 | 150 | 226 | 310 |
| 6 | 18 | 44 | 90 | 158 | 323 | 485 | 667 |
| 8 | 32 | 80 | 160 | 282 | 575 | 864 | 1,187 |
| 12 | 73 | 181 | 338 | 487 | 865 | 1,352 | 1,948 |
| 16 | 130 | 313 | 506 | 728 | 1,295 | 2,024 | 2,914 |
| Reducer Ratio | | | | | | | |
| | 15 | 20 | 25 | 30 | 40 | 50 | 60 |

Other Motions (stops and index periods) available. Contact your DE-STA-CO sales representative for more information.

Features

- R225 Reducer (Ratios from 15:1 to 60:1)
- Single Extended wormshaft (Standard)
- Double Extended Camshaft (Input Shaft)
- Center Thru Hole (2.25 in. Diameter)
- 1 hp AC Drive Package with Inverter Duty Motor and IM-pAC AC Drive (up to 60 cpm)
- Cycle Cam and Limit Switch Mounted to Camshaft
- Right Hand Cam

Optional Accessories

- 1 hp DC Motor
- Varipak DC Motor Control (up to 30 cpm)
- Output Overload Clutch model 7.8D
 - Available Settings (in-lbs): 1400, 1700, 2600, 3200, 4200, 5000, 7200, 10000
- Stationary Center Post
- Dual Cam and Limit Switch
- Base Riser Blocks
- Electric Clutch-Brake
- Left Hand Cam
- Relief in Dwell for shot-pin applications

Output Load Capacity (loads carried during index):

| | |
|--------------|--------------|
| Radial | 3,540 lbs |
| Thrust/Axial | 7,000 lbs |
| Moment | 21,620 in-lb |

Typical Application

Dial Diameter:

20 in. to 48 in.

Accuracy

±27 arcsec / ±.003" at 24" Radius

Repeatability

±7 arcsec / ±.0008" at 24" Radius

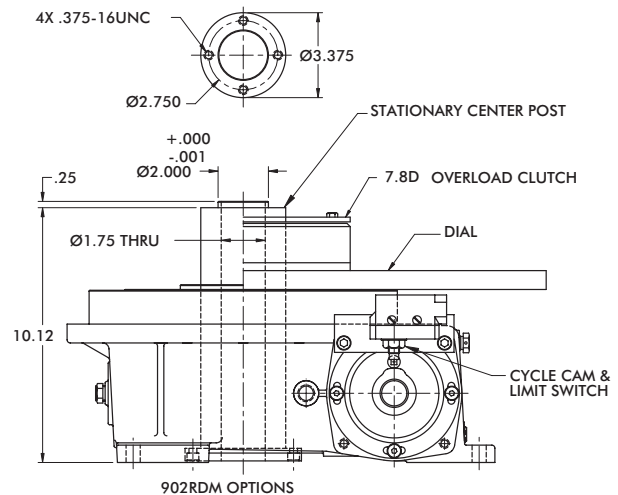

Unless otherwise noted,
all dimensions are in inches.

1100RDM SERIES

Precision Indexing | Dimensions

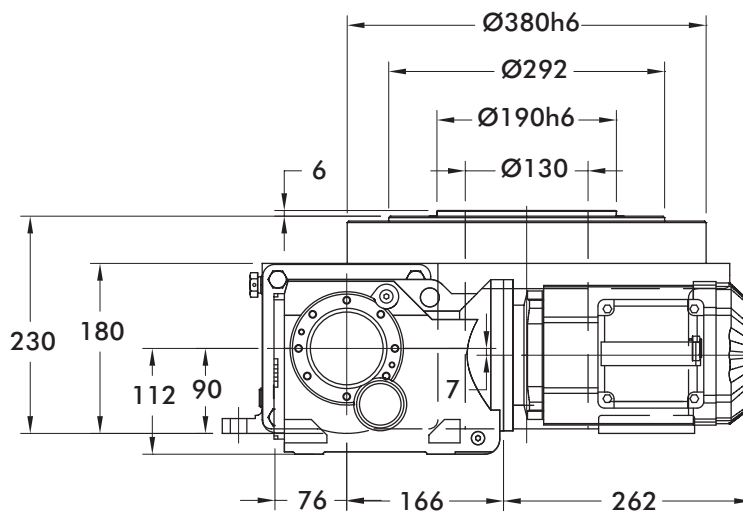
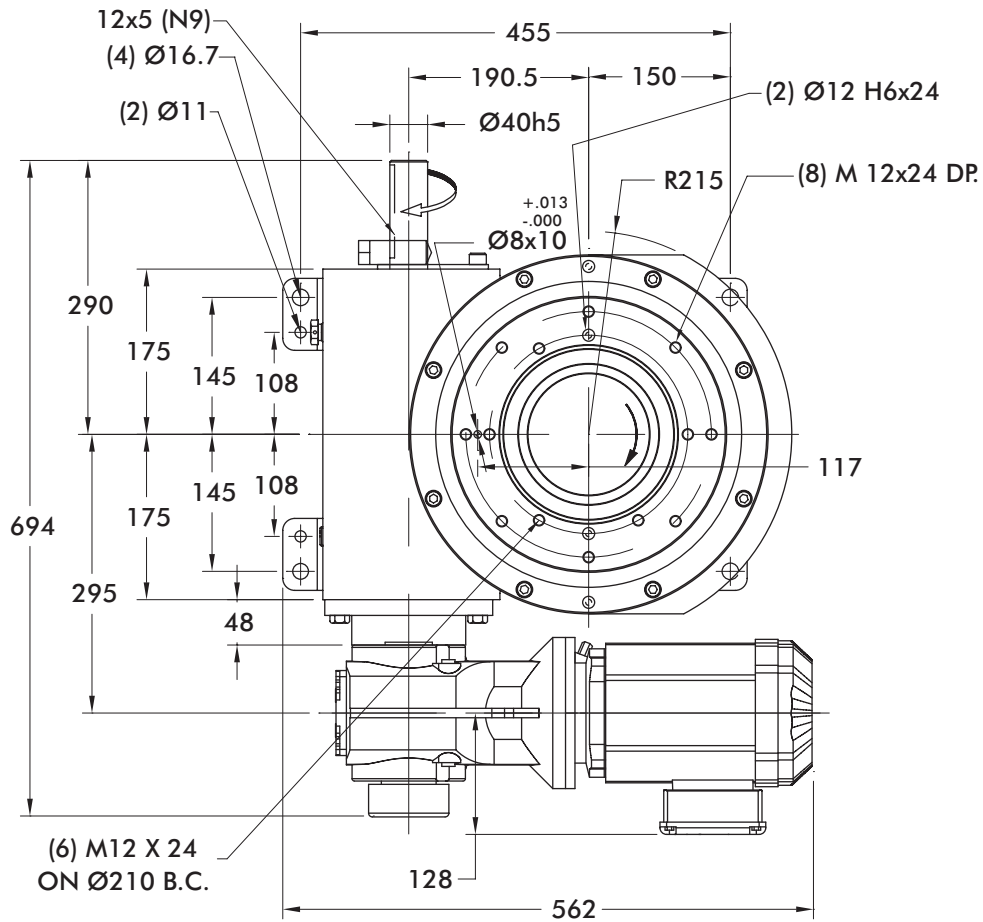

Unless otherwise noted, all dimensions are in mm.

1100RDM SERIES

Precision Indexing | Product Overview, Technical Specifications

| Maximum Inertia x 1000 [lb-in ²] for standard package | | | | | | | |
|---|-----------------------|-------|-------|-------|-------|-------|-------|
| Stops | Motion Time [seconds] | | | | | | |
| | 0.458 | 0.611 | 0.764 | 0.917 | 1.222 | 1.528 | 1.833 |
| 2 | 1 | 5 | 11 | 22 | 60 | 117 | 177 |
| 3 | 6 | 13 | 27 | 52 | 137 | 265 | 400 |
| 4 | 13 | 27 | 55 | 104 | 270 | 521 | 785 |
| 6 | 30 | 61 | 120 | 227 | 582 | 1,122 | 1,688 |
| 8 | 55 | 111 | 216 | 405 | 1,037 | 1,995 | 2,705 |
| 12 | 126 | 251 | 488 | 913 | 2,335 | 4,293 | 5,786 |
| 16 | 225 | 449 | 869 | 1,414 | 2,659 | 4,061 | 5,474 |
| Reducer Ratio | | | | | | | |
| | 15.86 | 19.58 | 24.06 | 29.32 | 39.61 | 48.95 | 56.83 |

Other Motions (stops and index periods) available. Contact your DE-STA-CO sales representative for more information.

Features

- KH47 Reducer and AC Motor with Optional Brake
- Double Extended Camshaft (Input Shaft)
- Center Thru Hole (130 mm / 5.1 in. Diameter)
- AC drive package with Inverter Duty Motor and Inverter Drive (up to 60 cpm)
- Cycle Cam and Limit Switch Mounted to Camshaft
- Right Hand Cam

Output Load Capacity (loads carried during index):

| | |
|--------------|---------------|
| Radial | 3100 lbs |
| Thrust/Axial | 8000 lbs |
| Moment | 28,674 in-lbs |

Typical Application Dial Diameter:

20 in. to 60 in.

Accuracy

±22 arcsec / ±.003" at 30" Radius

Repeatability

±5 arcsec / ±.0008" at 30" Radius

Optional Accessories

- 7300C Reducer (Ratios from 15:1 to 60:1)
- 1.5 hp DC motor
- Varipak DC Motor Control (up to 30 cpm)
- 7350C Heavy Duty Reducer (Ratios from 10:1 to 60:1)
- Stationary Center Post
- Dual Cam and Limit Switch
- Left Hand Cam
- Relief in Dwell for shot-pin applications

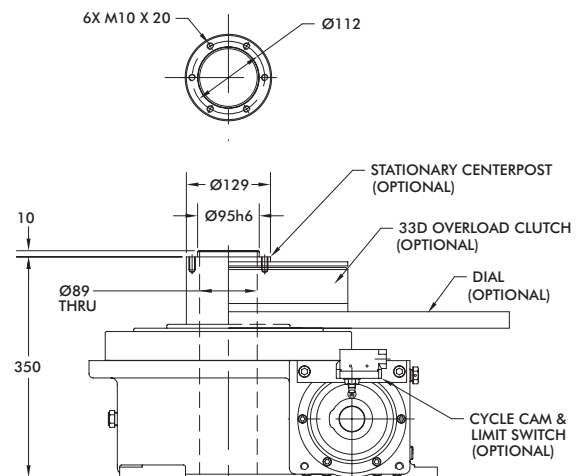

Unless otherwise noted,
all dimensions are in mm.

1305RDM SERIES

Precision Indexing | Dimensions

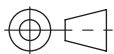
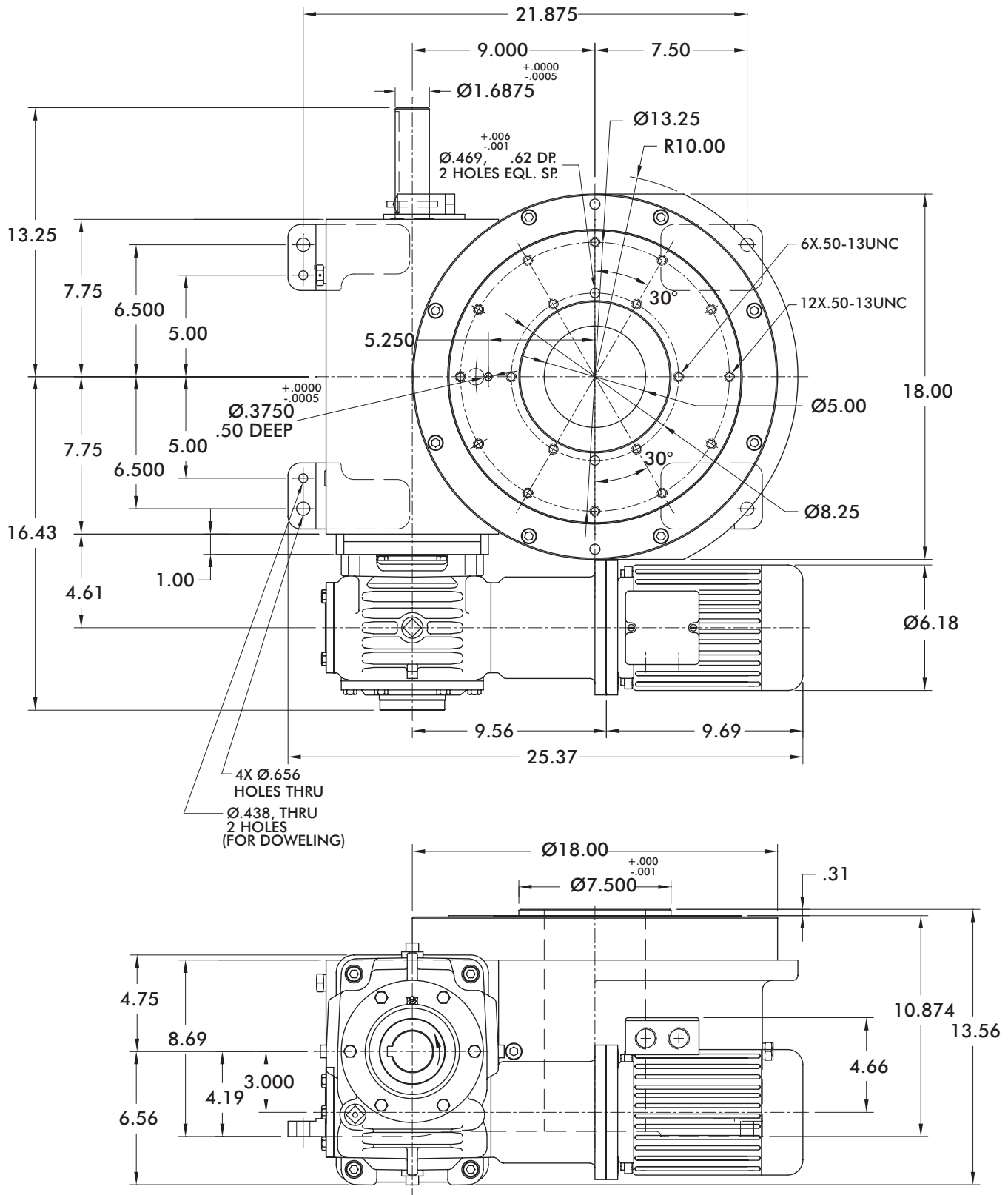

Unless otherwise noted, all dimensions are in inches.

1305RDM SERIES

Precision Indexing | Product Overview, Technical Specifications

| Maximum Inertia x 1000 [lb-in ²] for standard package | | | | | | | |
|---|-----------------------|-------|-------|-------|-------|-------|-------|
| Stops | Motion Time [seconds] | | | | | | |
| | 0.458 | 0.611 | 0.764 | 0.917 | 1.222 | 1.528 | 1.833 |
| 2 | 0 | 4 | 13 | 26 | 48 | 73 | 102 |
| 3 | 2 | 11 | 26 | 50 | 88 | 133 | 184 |
| 4 | 10 | 32 | 71 | 130 | 227 | 340 | 467 |
| 6 | 25 | 72 | 154 | 281 | 485 | 724 | 994 |
| 8 | 47 | 131 | 277 | 502 | 864 | 1,290 | 1,770 |
| 12 | 111 | 300 | 629 | 1,134 | 1,950 | 2,908 | 3,988 |
| 16 | 200 | 537 | 1,121 | 2,019 | 3,470 | 5,173 | 7,092 |
| Reducer Ratio | | | | | | | |
| | 15 | 20 | 25 | 30 | 40 | 50 | 60 |

Other Motions (stops and index periods) available. Contact your DE-STA-CO sales representative for more information.

Features

- 7300C Reducer (Ratios from 15:1 to 60:1)
- Double Extended Camshaft (Input Shaft)
- Center Thru Hole (5.00 in. Diameter)
- 2 hp AC Drive Package with Inverter Duty Motor and Inverter Drive (up to 60 cpm)
- Cycle Cam and Limit Switch Mounted to Camshaft
- Right Hand Cam

Output Load Capacity (loads carried during index):

| | |
|--------------|--------------|
| Radial | 4,650 lbs |
| Thrust/Axial | 11,650 lbs |
| Moment | 40,528 in-lb |

Typical Application

| | |
|-----------------------|-----------------------------------|
| Dial Diameter: | 20 in. to 72 in. |
| Accuracy | ±38 arcsec / ±.007" at 36" Radius |
| Repeatability | ±10 arcsec / ±.002" at 36" Radius |

Optional Accessories

- 2 hp DC Motor
- Varipak DC Motor Control (up to 30 cpm)
- 7350C Heavy Duty Reducer (Ratios from 10:1 to 60:1)
- Output Overload Clutch model 32D
 - Available Settings (in-lbs): 8500, 13000, 20000, 31000
- Stationary Center Post
- Dual Cam and Limit Switch
- Base Riser Blocks
- Electric Clutch-Brake
- Left Hand Cam
- Relief in Dwell for shot-pin applications

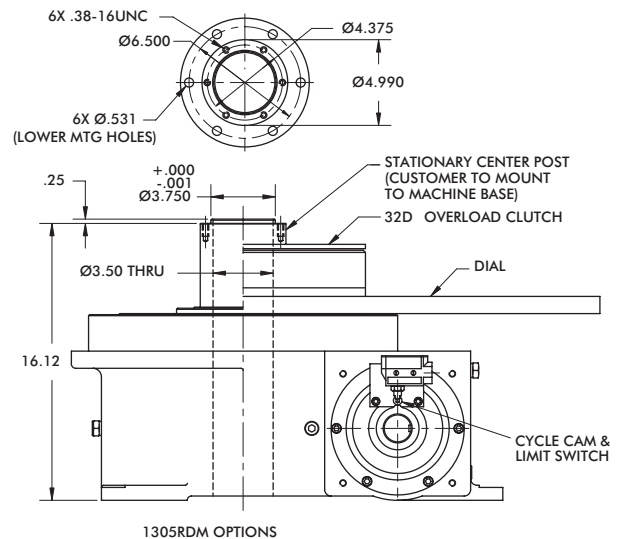

Unless otherwise noted, all dimensions are in inches.

1800RDM SERIES

Precision Indexing | Dimensions

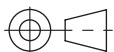
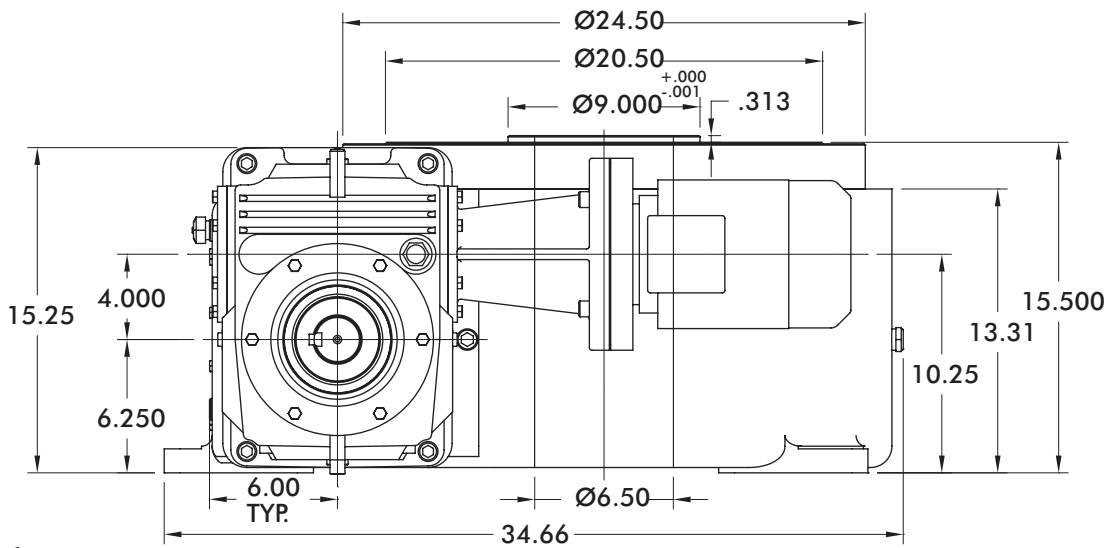
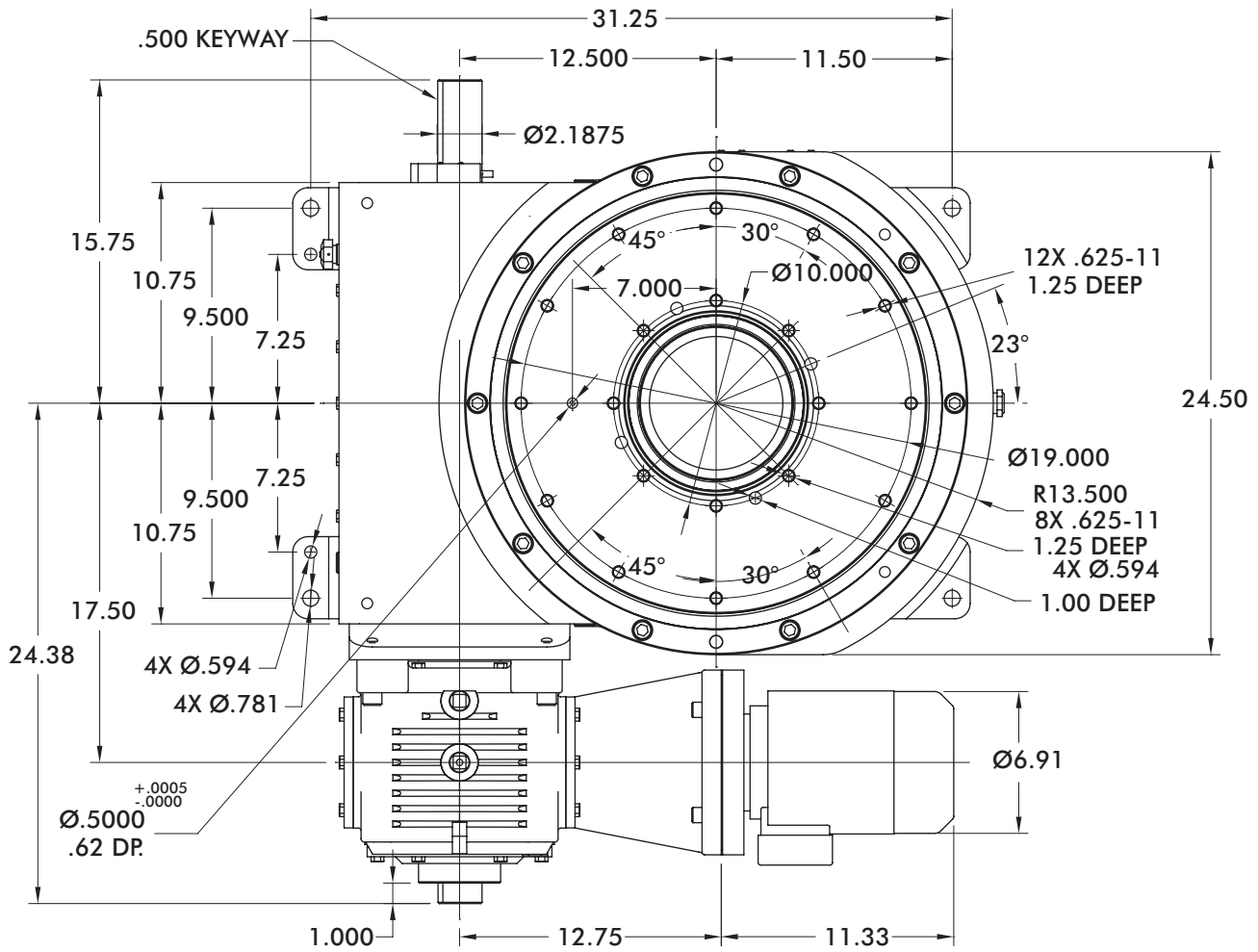

Unless otherwise noted, all dimensions are in inches.

1800RDM SERIES

Precision Indexing | Product Overview, Technical Specifications

| Maximum Inertia x 1000 [lb-in ²] for standard package | | | | | | | |
|---|-----------------------|-------|-------|-------|-------|--------|--------|
| Stops | Motion Time [seconds] | | | | | | |
| | 0.458 | 0.611 | 0.764 | 0.917 | 1.222 | 1.528 | 1.833 |
| 2 | 0 | 0 | 8 | 27 | 91 | 182 | 256 |
| 3 | 0 | 11 | 41 | 87 | 246 | 472 | 655 |
| 4 | 1 | 31 | 85 | 169 | 455 | 862 | 1,192 |
| 6 | 19 | 83 | 197 | 375 | 981 | 1,842 | 2,542 |
| 8 | 45 | 158 | 361 | 678 | 1,754 | 3,286 | 4,530 |
| 12 | 120 | 376 | 832 | 1,544 | 3,966 | 7,412 | 10,211 |
| 16 | 224 | 679 | 1,490 | 2,756 | 7,062 | 13,188 | 18,163 |
| Reducer Ratio | | | | | | | |
| | 15 | 20 | 25 | 30 | 40 | 50 | 60 |

Features

- 7400C Reducer (Ratios from 15:1 to 60:1)
- Double Extended Camshaft (Input Shaft)
- Center Thru Hole (6.50 in. Diameter)
- 2 or 3 hp AC Drive Package with Inverter Duty Motor and Inverter Drive (up to 60 cpm)
- Cycle Cam and Limit Switch Mounted to Camshaft
- Right Hand Cam

Output Load Capacity (loads carried during index):

| | |
|--------------|--------------|
| Radial | 5,850 lbs |
| Thrust/Axial | 14,650 lbs |
| Moment | 68,119 in-lb |

Typical Application

| | |
|-----------------------|-----------------------------------|
| Dial Diameter: | 26 in. to 96 in. |
| Accuracy | ±27 arcsec / ±.006" at 48" Radius |
| Repeatability | ±7 arcsec / ±.0016" at 48" Radius |

Optional Accessories

- 2 hp DC Motor with Varipak DC Motor Control (up to 30 cpm)
- 3 hp DC Motor
- 7500C Heavy Duty Reducer (Ratios from 10:1 to 60:1)
- Output Overload Clutch model 61D – Available Settings (in-lbs): 23000, 36000, 44000, 50000, 60000
- Stationary Center Post
- Dual Cam and Limit Switch
- Base Riser Blocks
- Electric Clutch-Brake
- Left Hand Cam
- Relief in Dwell for shot-pin applications

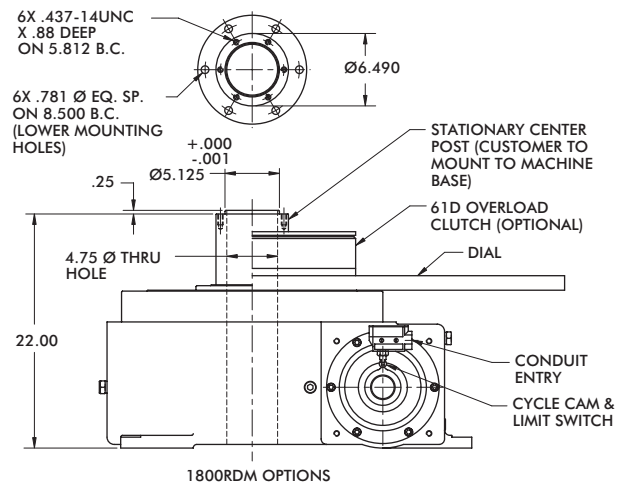

Unless otherwise noted, all dimensions are in inches.