



Modular Lightweight Power Clamp

82L-3E

October 2020

Christian Schubert



82L*G-2...

Actual design

- Opening angle 105°
- Opening angle adjustment by washers in the cylinder
- Adjustment of the sensors necessary
- Bronze bushings for the drive shaft (Tolerance issues)

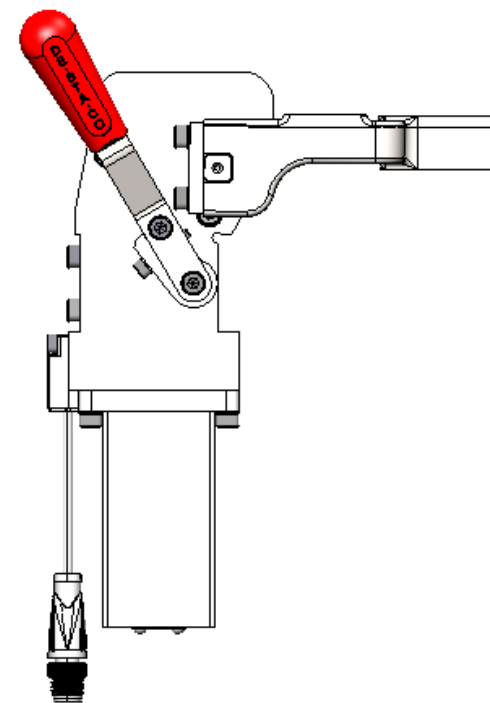

82L-3E... (New)

New design

- Modular Design
- Opening angle 105°
- Opening angle adjustment from the 82M-3E added
- No additional adjustment of the sensors needed
- Needle bearings for a better arm guidance implemented
- Open Pin function from the 82M-3E added
- Dowel holes in the front and rear shoulder added

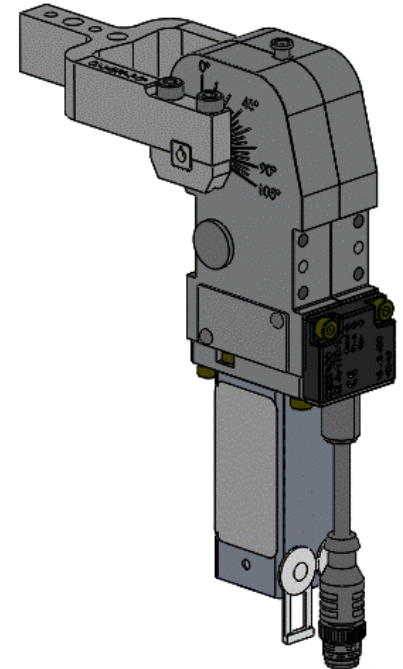

82L-3E... (New) Improvements

Open angle adjustment

Open angle adjustment implemented.
Same as on the existing 82M-3E design

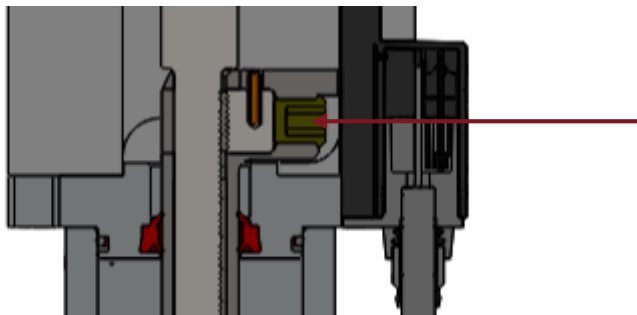

Needle bearings

The bronze bushings for the drive shaft will be
Replaced by needle bearings

Better clamp arm guidance

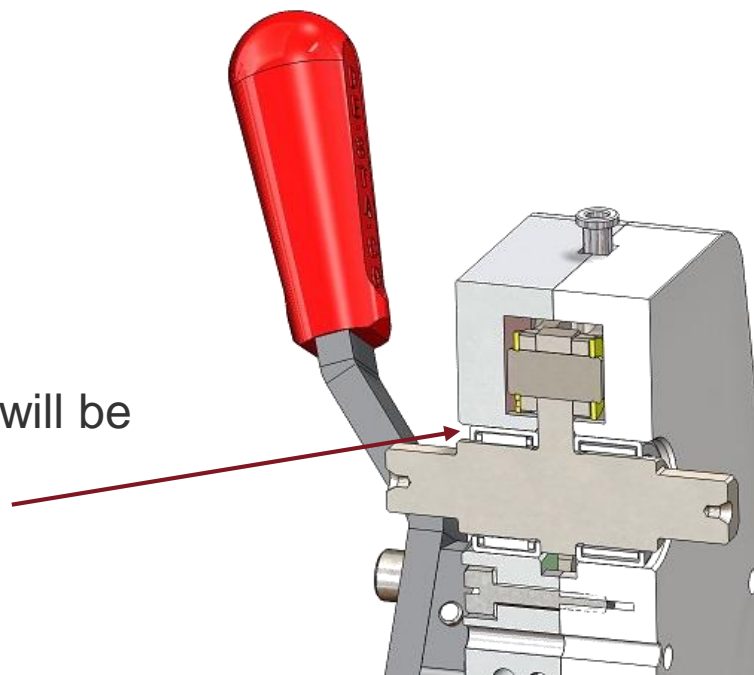

82L-3E... (New) Improvements

Opening pin

All size will receive an opening pin to unlock the clamp if air is lost

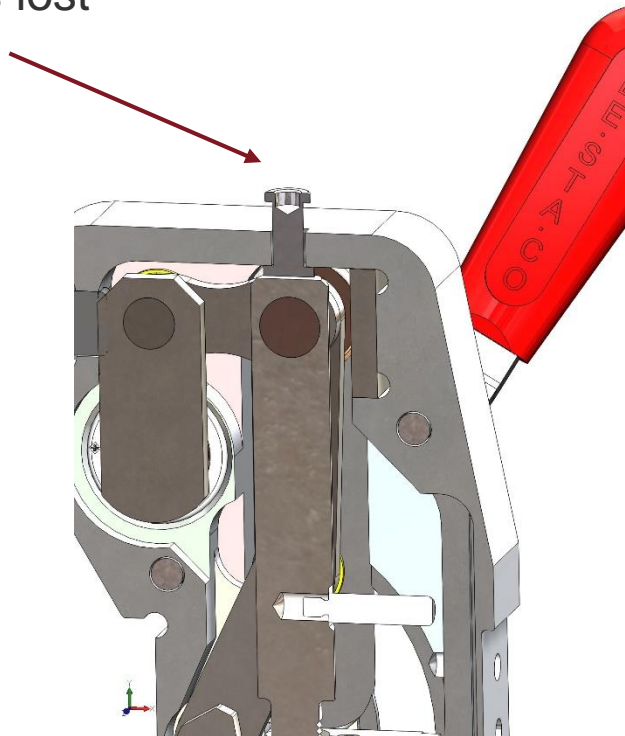

Mounting Dowel holes

Size 32 and 40 will have dowel holes in the front and rear shoulder

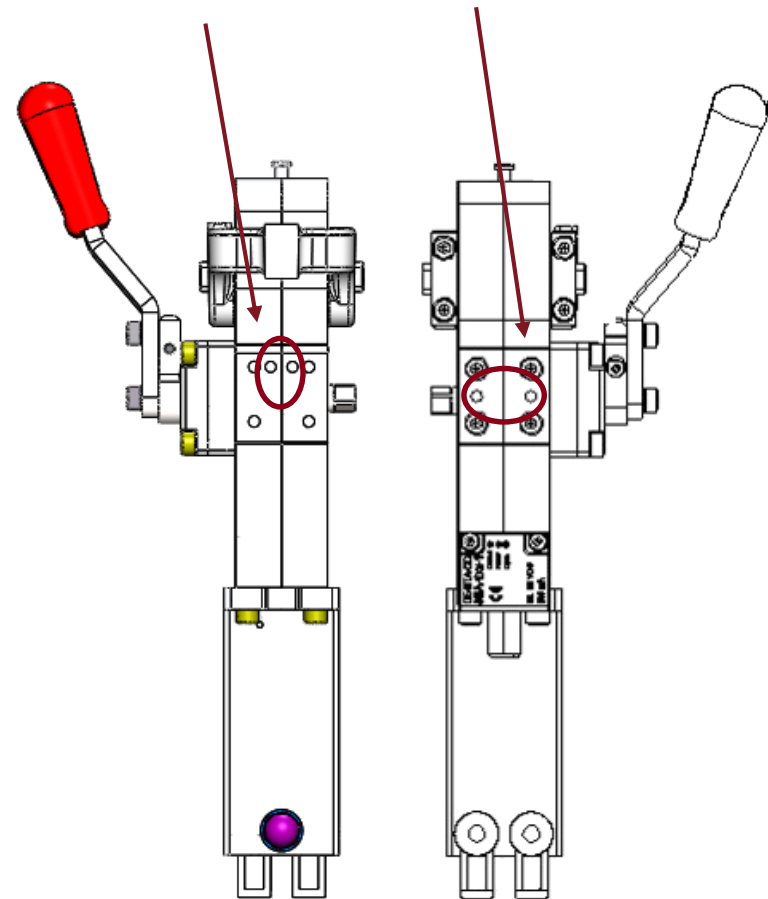

82L-3E... (New) Improvements

Sensing system

No additional adjustment of the sensors needed.
Complete enclosed one piece sensor.

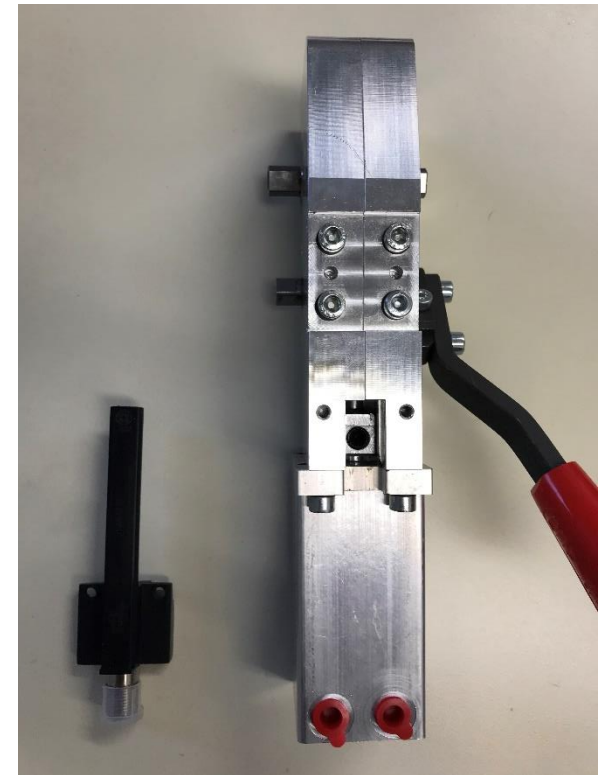
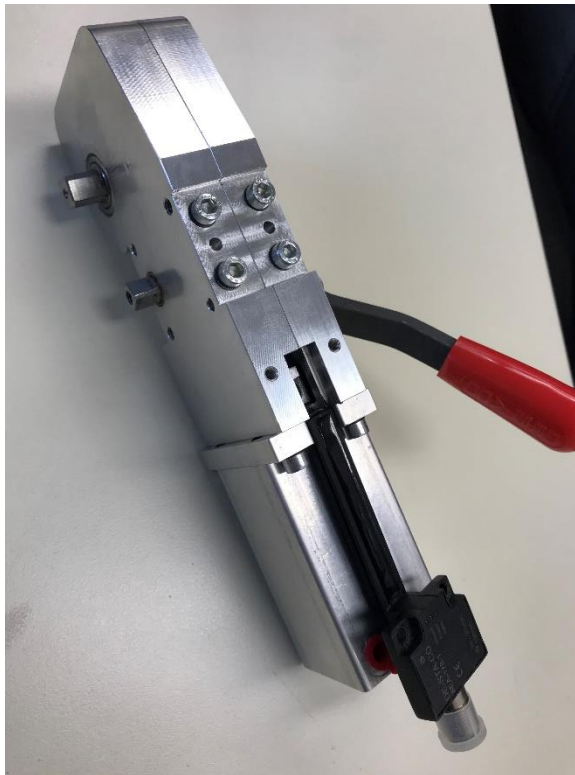
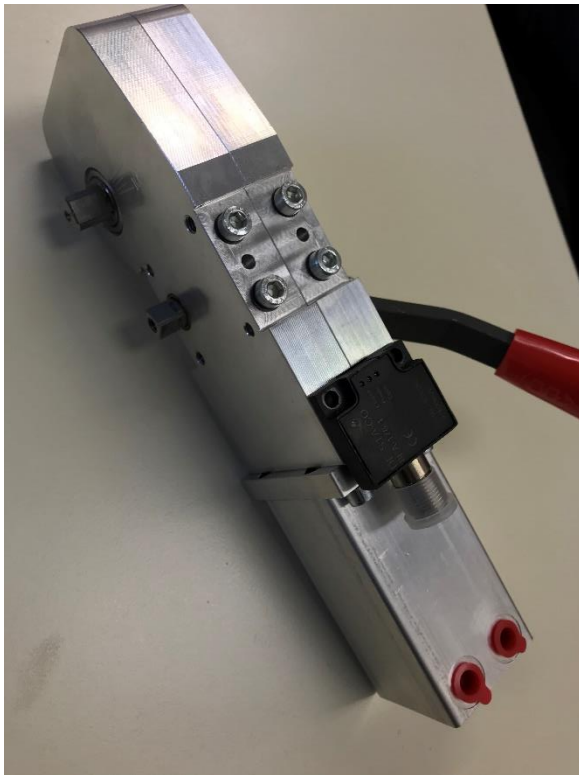

82L-3E... (New) Hand Lever versions

Hand lever

We added to our classic red handle design
A green handle line as standard.



Red Option

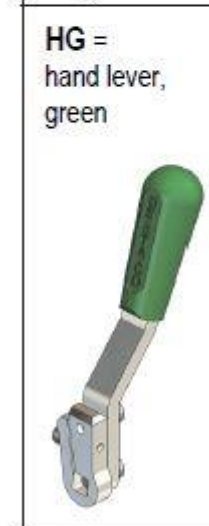

Green Option

Hand lever

82L-3E... (New) Clamping arms

Clamping arms

All existing clamps arms can be used.

Spannarmer für / Clamping arms for 82L-3E

82L-3E xx xx 25 xx

8JG-075-3-01

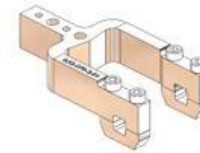

82L-3E xx xx 32 xx

8JG-066-1-01



8JG-065-2-01



8JG-363-1-01



82L-3E xx xx 40 xx

8JG-068-1-01



8JG-067-2-01



8JG-364-1-01

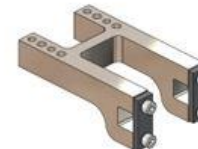

82L-3E... (New) Comparison Size 25

- Dowel hole \varnothing changed from $\varnothing 5$ H7 to $\varnothing 4$ H7
- Side mounting Option for the Automatic version added

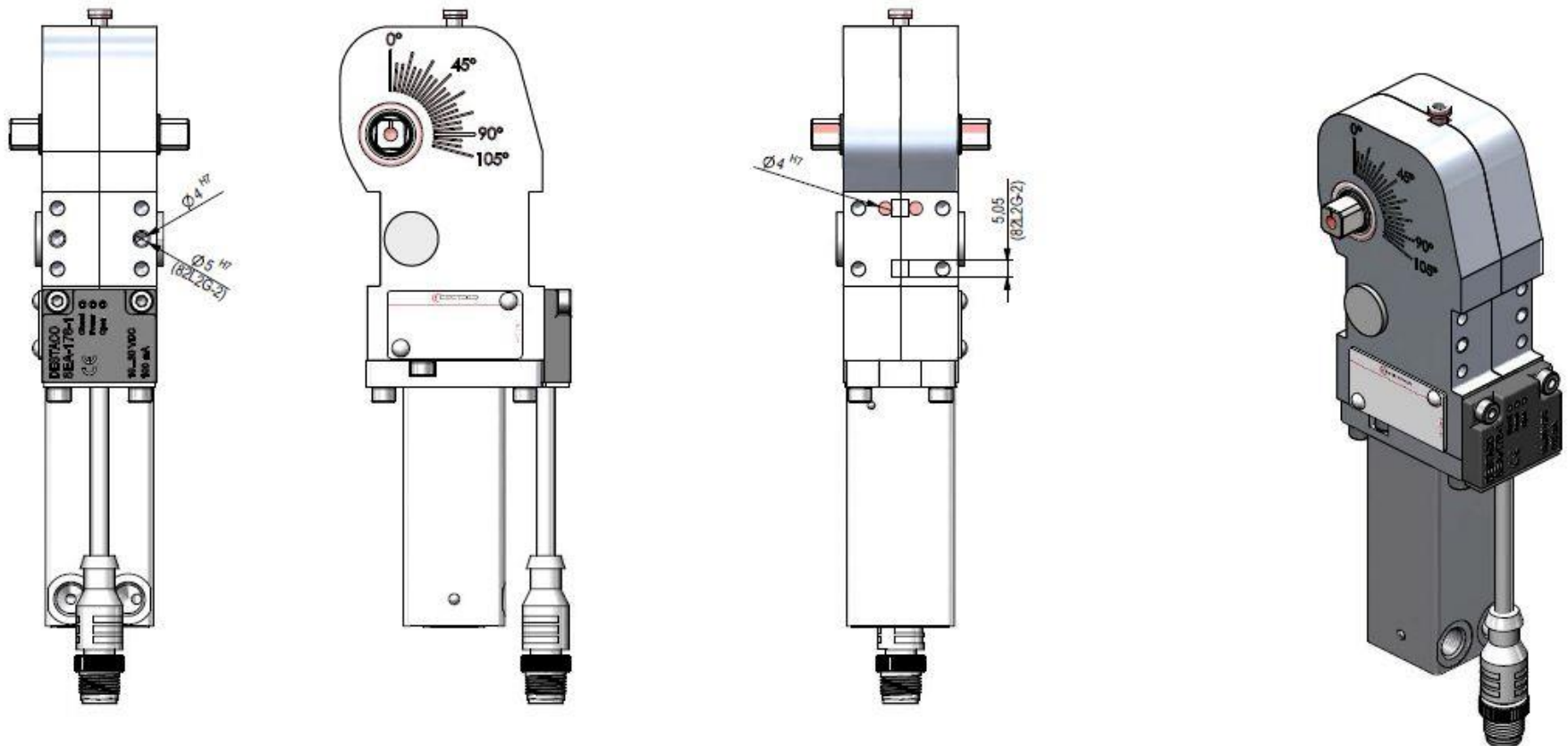

82L-3E... (New) Comparison

- One housing for automatic and hand lever version
- Slim Head design
- Longer Design based on open angle adjustment feature
- Dowel hole \varnothing changed from $\varnothing 6$ H7 to $\varnothing 4$ H7

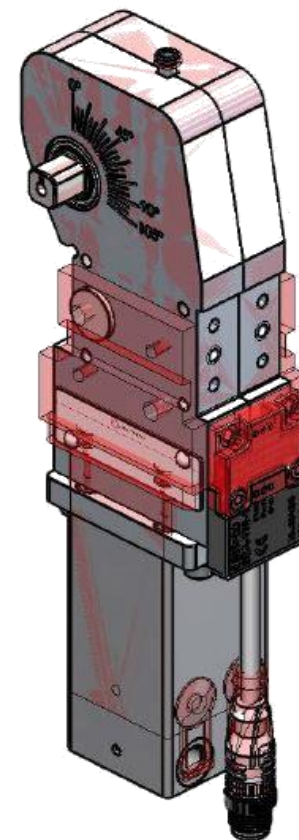
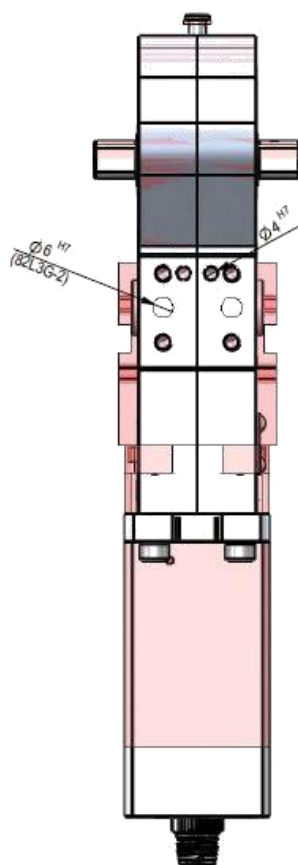
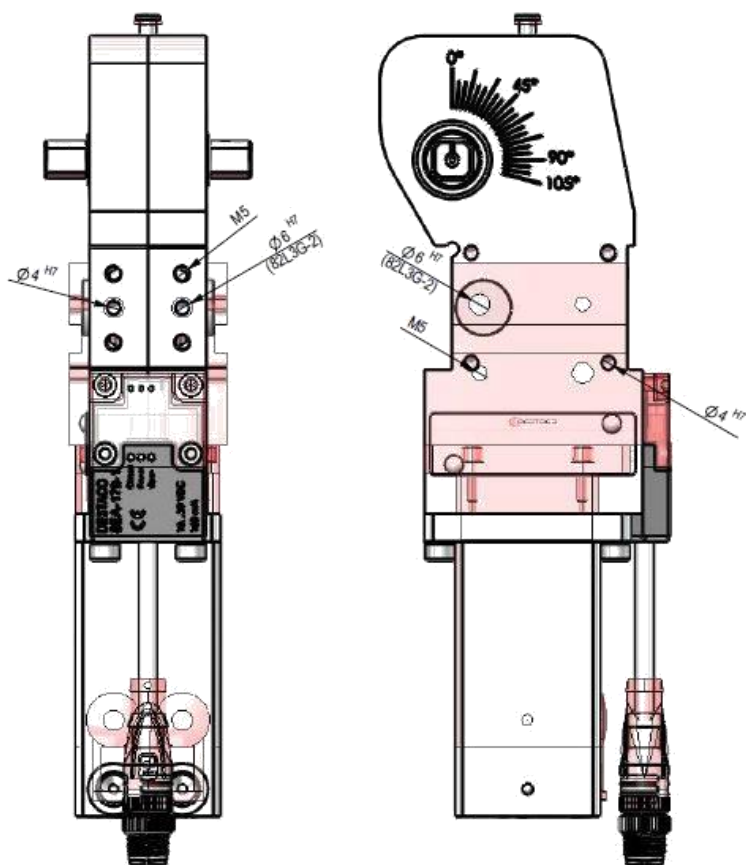

82L-3E... (New) Comparison Size 40

- Longer Design based on open angle adjustment feature
- One housing for automatic and hand lever version
- Dowel hole \varnothing changed from $\varnothing 6$ H7 to $\varnothing 5$ H7

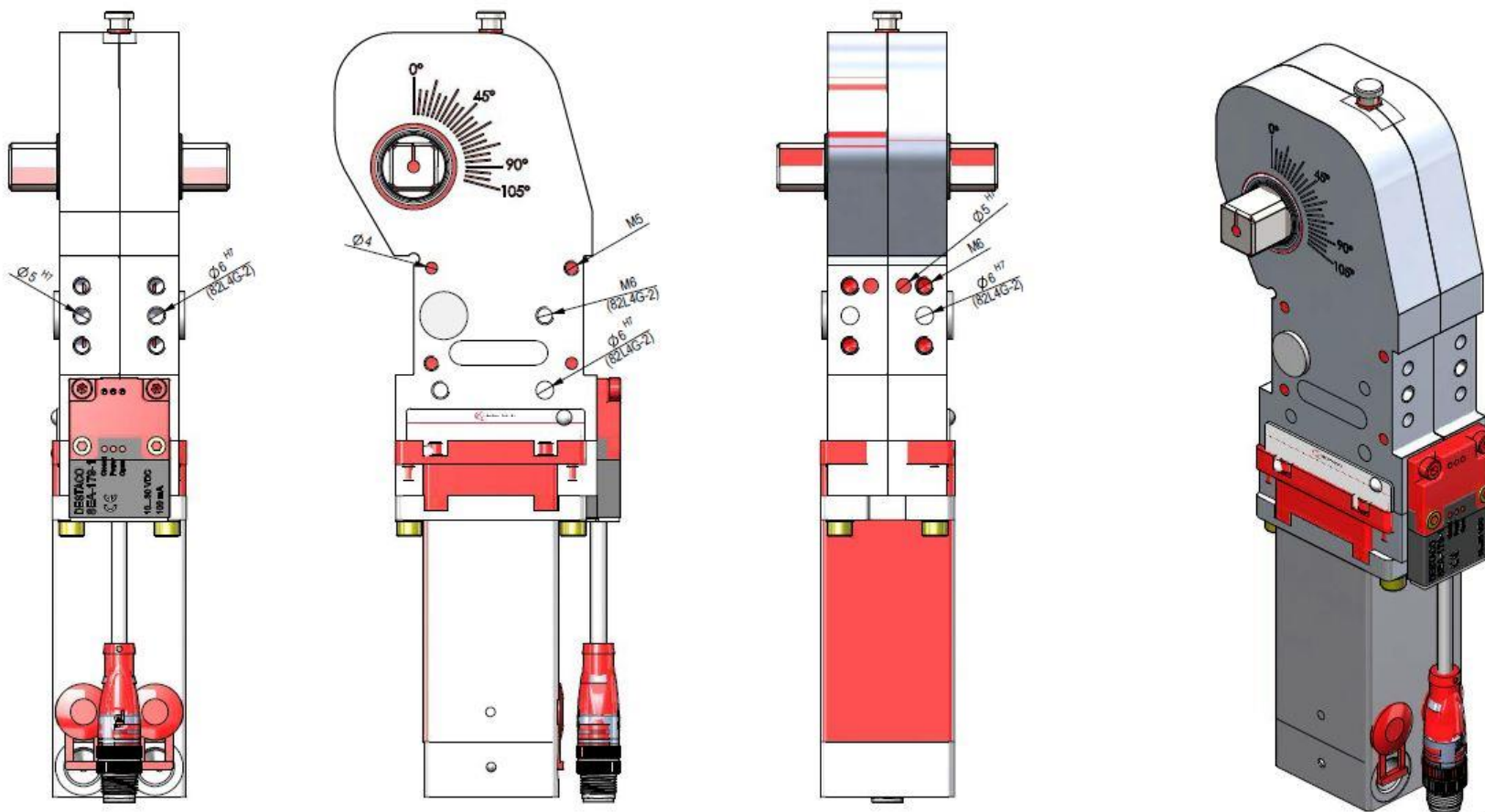

Rendelési útmutató Példa: 82L-3E 23 00 40 C8

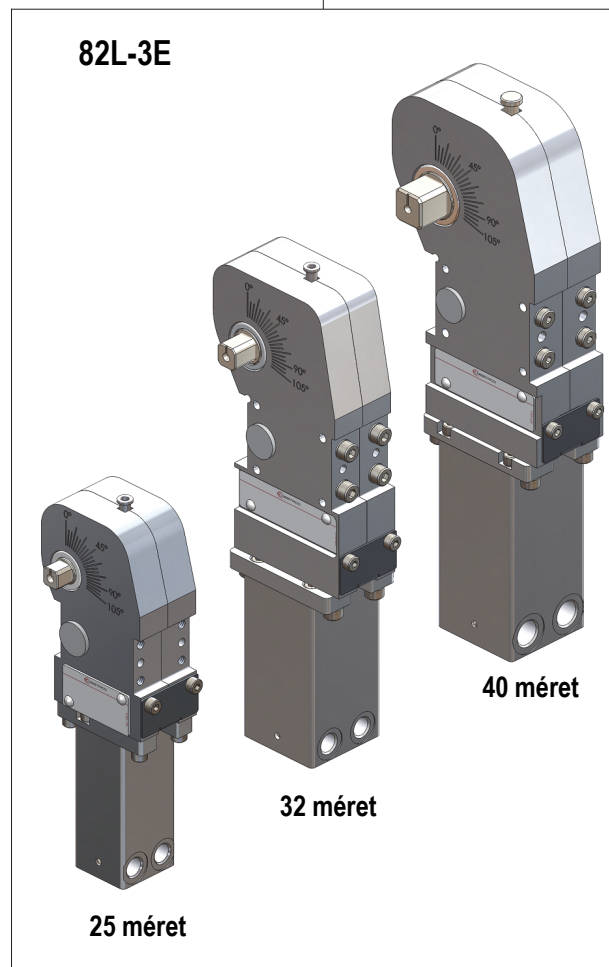

Alapmodell

A méreteket lásd az adatlapon

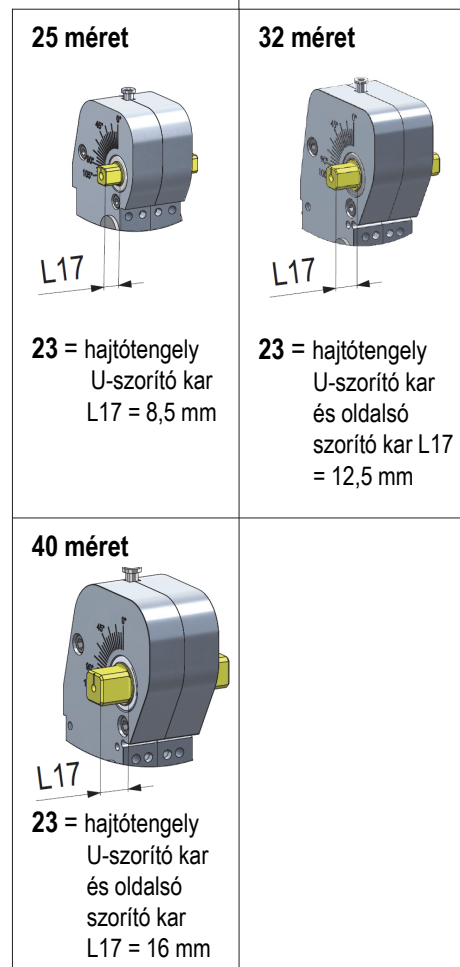

Kardántengely

A méreteket lásd az adatlapon

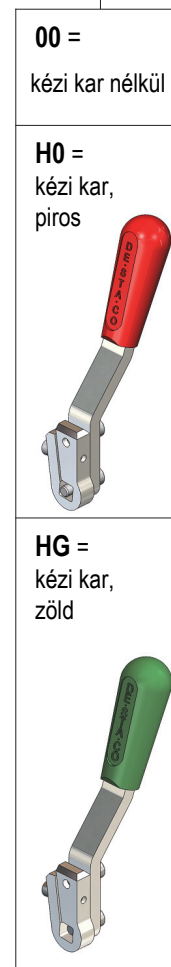

Kézi karral

A méreteket lásd az adatlapon

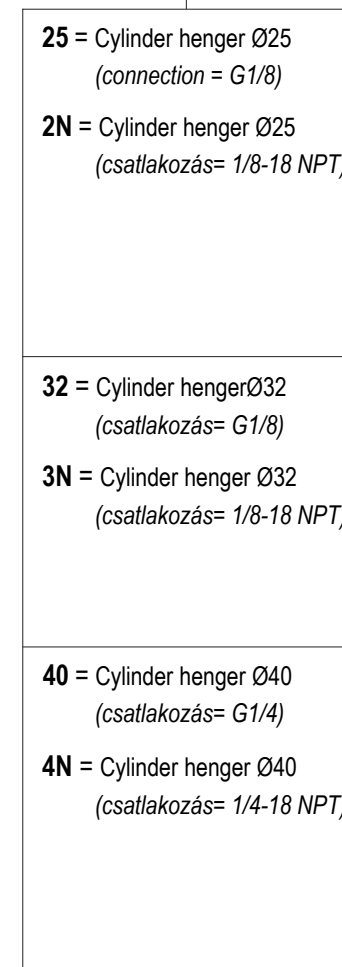

Cylinder henger

A méreteket lásd az adatlapon

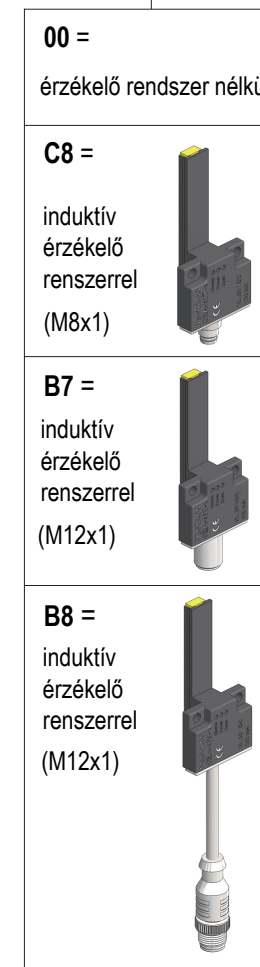

Sensing system

Dimensions see data sheet

Many Thanks for your attention

