

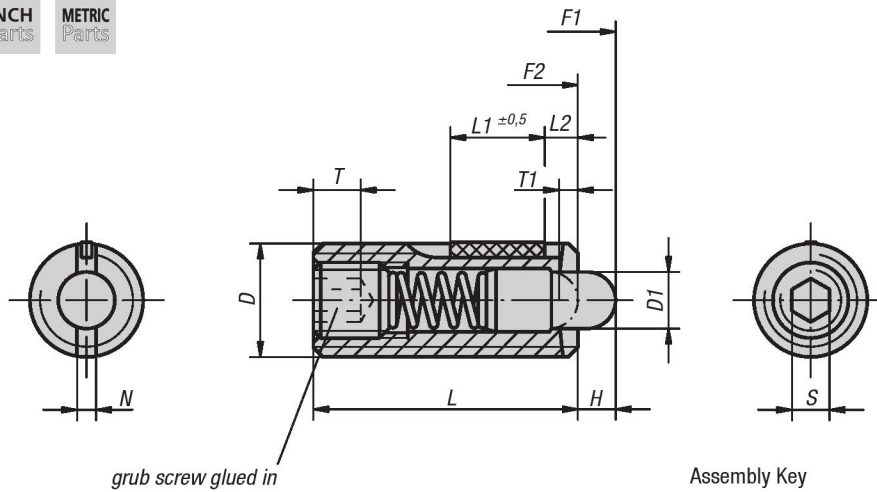

# Spring Plungers

LONG-LOK, pin style, hexagon socket, steel body and pin

INCH Parts METRIC Parts



L2 = approx. 2x thread pitch

Assembly Key

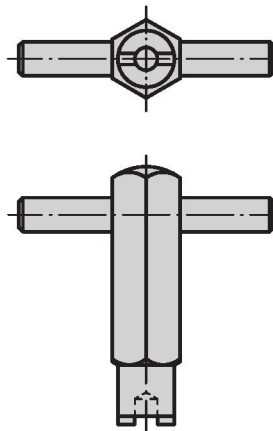

**Material:**  
 Body in steel quality class 5.8.  
 Pressure pin in steel.  
 Spring in steel class D.

LONG-LOK thread system nylon

**Type:**  
 Black oxide finish.  
 Pressure pin hardened.

**Part Number Example:**  
 K0327.1A1

## KIPP Spring Plungers, LONG-LOK, pin style, hexagon socket, steel body and pin, standard end pressure, inch

| Item No. | D       | D1  | L  | L1 | H   | T   | T1  | N   | S    | Spring force initial pressure F1 approx. N | Spring force final pressure F2 approx. N | Tightening torque approx. Nm | Loosening torque, after third unscrewing approx. Nm | Item No. Assembly key |
|----------|---------|-----|----|----|-----|-----|-----|-----|------|--|--|------------------------------|---|-----------------------|
| K0327.A1 | 10-32   | 2.4 | 18 | 7  | 2.3 | 2   | 0.8 | 0.8 | 1/16 | 6  | 20                                       | 0.12                         | 0.08  | K0317.905             |
| K0327.AJ | 1/4-28  | 2.7 | 20 | 7  | 2.5 | 2.5 | 1   | 1   | 5/64 | 7  | 20                                       | 0.45                         | 0.22  | K0317.906             |
| K0327.A2 | 1/4-20  | 2.7 | 20 | 7  | 2.5 | 2.5 | 1   | 1   | 5/64 | 7  | 20                                       | 0.45                         | 0.22  | K0317.906             |
| K0327.A3 | 5/16-18 | 3.5 | 22 | 8  | 3   | 3   | 1.4 | 1.2 | 3/32 | 9  | 35                                       | 1.05                         | 0.37  | K0317.908             |
| K0327.A4 | 3/8-16  | 4   | 22 | 9  | 3   | 3.5 | 1.4 | 1.6 | 1/8  | 9  | 35                                       | 1.30                         | 0.60  | K0317.910             |
| K0327.A5 | 1/2-13  | 6   | 28 | 10 | 4   | 5   | 2   | 2   | 5/32 | 12   | 55                                       | 2.00                         | 1.30  | K0317.912             |
| K0327.A6 | 5/8-11  | 7.5 | 32 | 14 | 5   | 6   | 2.5 | 2.5 | 3/16 | 45   | 100                                      | 3.90                         | 3.00  | K0317.916             |

## KIPP Spring Plungers, LONG-LOK, pin style, hexagon socket, steel body and pin, light end pressure, inch

| Item No.  | D       | D1  | L  | L1 | H   | T   | T1  | N   | S    | Spring force initial pressure F1 approx. N | Spring force final pressure F2 approx. N | Tightening torque approx. Nm | Loosening torque, after third unscrewing approx. Nm | Item No. Assembly key |
|-----------|---------|-----|----|----|-----|-----|-----|-----|------|--|--|------------------------------|---|-----------------------|
| K0327.1A1 | 10-32   | 2.4 | 18 | 7  | 2.3 | 2   | 0.8 | 0.8 | 1/16 | 3  | 10                                       | 0.12                         | 0.08  | K0317.905             |
| K0327.1AJ | 1/4-28  | 2.7 | 20 | 7  | 2.5 | 2.5 | 1   | 1   | 5/64 | 3  | 9  | 0.45                         | 0.22  | K0317.906             |
| K0327.1A2 | 1/4-20  | 2.7 | 20 | 7  | 2.5 | 2.5 | 1   | 1   | 5/64 | 3  | 9  | 0.45                         | 0.22  | K0317.906             |
| K0327.1A3 | 5/16-18 | 3.5 | 22 | 8  | 3   | 3   | 1.4 | 1.2 | 3/32 | 4  | 16                                       | 1.05                         | 0.37  | K0317.908             |
| K0327.1A4 | 3/8-16  | 4   | 22 | 9  | 3   | 3.5 | 1.4 | 1.6 | 1/8  | 4  | 16                                       | 1.30                         | 0.60  | K0317.910             |
| K0327.1A5 | 1/2-13  | 6   | 28 | 10 | 4   | 5   | 2   | 2   | 5/32 | 5  | 27                                       | 2.00                         | 1.30  | K0317.912             |
| K0327.1A6 | 5/8-11  | 7.5 | 32 | 14 | 5   | 6   | 2.5 | 2.5 | 3/16 | 20   | 45                                       | 3.90                         | 3.00  | K0317.916             |



# Spring Plungers

LONG-LOK, pin style, hexagon socket, steel body and pin

## KIPP Spring Plungers, LONG-LOK, pin style, hexagon socket, steel body and pin, heavy end pressure, inch

| Item No.  | D       | D1  | L  | L1 | H   | T   | T1  | N   | S    | Spring force initial pressure F1 approx. N | Spring force final pressure F2 approx. N | Tightening torque approx. Nm | Loosening torque, after third unscrewing approx. Nm | Item No. Assembly key |
|-----------|---------|-----|----|----|-----|-----|-----|-----|------|--|--|------------------------------|---|-----------------------|
| K0327.2A1 | 10-32   | 2.4 | 18 | 7  | 2.3 | 2   | 0.8 | 0.8 | 1/16 | 11   | 29                                       | 0.12                         | 0.08  | K0317.905             |
| K0327.2AJ | 1/4-28  | 2.7 | 20 | 7  | 2.5 | 2.5 | 1   | 1   | 5/64 | 14   | 37                                       | 0.45                         | 0.22  | K0317.906             |
| K0327.2A2 | 1/4-20  | 2.7 | 20 | 7  | 2.5 | 2.5 | 1   | 1   | 5/64 | 14   | 37                                       | 0.45                         | 0.22  | K0317.906             |
| K0327.2A3 | 5/16-18 | 3.5 | 22 | 8  | 3   | 3   | 1.4 | 1.2 | 3/32 | 22   | 65                                       | 1.05                         | 0.37  | K0317.908             |
| K0327.2A4 | 3/8-16  | 4   | 22 | 9  | 3   | 3.5 | 1.4 | 1.6 | 1/8  | 19   | 70                                       | 1.30                         | 0.60  | K0317.910             |
| K0327.2A5 | 1/2-13  | 6   | 28 | 10 | 4   | 5   | 2   | 2   | 5/32 | 25   | 85                                       | 2.00                         | 1.30  | K0317.912             |
| K0327.2A6 | 5/8-11  | 7.5 | 32 | 14 | 5   | 6   | 2.5 | 2.5 | 3/16 | 60   | 150                                      | 3.90                         | 3.00  | K0317.916             |

## KIPP Spring Plungers, LONG-LOK, pin style, hexagon socket, steel body and pin, standard end pressure, metric

| Item No. | D   | D1  | L  | L1 | H   | T   | T1  | N   | S   | Spring force initial pressure F1 approx. N | Spring force final pressure F2 approx. N | Tightening torque approx. Nm | Loosening torque, after third unscrewing approx. Nm | Item No. Assembly key |
|----------|-----|-----|----|----|-----|-----|-----|-----|-----|--|--|------------------------------|---|-----------------------|
| K0327.05 | M5  | 2,4 | 18 | 7  | 2,3 | 2   | 0,8 | 0,8 | 1,5 | 6  | 20                                       | 0,12                         | 0,08  | K0317.905             |
| K0327.06 | M6  | 2,7 | 20 | 7  | 2,5 | 2,5 | 1   | 1   | 2   | 7  | 20                                       | 0,45                         | 0,22  | K0317.906             |
| K0327.08 | M8  | 3,5 | 22 | 8  | 3   | 3   | 1,4 | 1,2 | 2,5 | 9  | 35                                       | 1,05                         | 0,37  | K0317.908             |
| K0327.10 | M10 | 4   | 22 | 9  | 3   | 3,5 | 1,4 | 1,6 | 3   | 9  | 35                                       | 1,30                         | 0,60  | K0317.910             |
| K0327.12 | M12 | 6   | 28 | 10 | 4   | 5   | 2   | 2   | 4   | 12   | 55                                       | 2,00                         | 1,30  | K0317.912             |
| K0327.16 | M16 | 7,5 | 32 | 14 | 5   | 6   | 2,5 | 2,5 | 5   | 45   | 100                                      | 3,90                         | 3,00  | K0317.916             |

## KIPP Spring Plungers, LONG-LOK, pin style, hexagon socket, steel body and pin, light end pressure, metric

| Item No.  | D   | D1  | L  | L1 | H   | T   | T1  | N   | S   | Spring force initial pressure F1 approx. N | Spring force final pressure F2 approx. N | Tightening torque approx. Nm | Loosening torque, after third unscrewing approx. Nm | Item No. Assembly key |
|-----------|-----|-----|----|----|-----|-----|-----|-----|-----|--|--|------------------------------|---|-----------------------|
| K0327.105 | M5  | 2,4 | 18 | 7  | 2,3 | 2   | 0,8 | 0,8 | 1,5 | 3  | 10                                       | 0,12                         | 0,08  | K0317.905             |
| K0327.106 | M6  | 2,7 | 20 | 7  | 2,5 | 2,5 | 1   | 1   | 2   | 3  | 9  | 0,45                         | 0,22  | K0317.906             |
| K0327.108 | M8  | 3,5 | 22 | 8  | 3   | 3   | 1,4 | 1,2 | 2,5 | 4  | 16                                       | 1,05                         | 0,37  | K0317.908             |
| K0327.110 | M10 | 4   | 22 | 9  | 3   | 3,5 | 1,4 | 1,6 | 3   | 4  | 16                                       | 1,30                         | 0,60  | K0317.910             |
| K0327.112 | M12 | 6   | 28 | 10 | 4   | 5   | 2   | 2   | 4   | 5  | 27                                       | 2,00                         | 1,30  | K0317.912             |
| K0327.116 | M16 | 7,5 | 32 | 14 | 5   | 6   | 2,5 | 2,5 | 5   | 20   | 45                                       | 3,90                         | 3,00  | K0317.916             |

## KIPP Spring Plungers, LONG-LOK, pin style, hexagon socket, steel body and pin, heavy end pressure, metric

| Item No.  | D   | D1  | L  | L1 | H   | T   | T1  | N   | S   | Spring force initial pressure F1 approx. N | Spring force final pressure F2 approx. N | Tightening torque approx. Nm | Loosening torque, after third unscrewing approx. Nm | Item No. Assembly key |
|-----------|-----|-----|----|----|-----|-----|-----|-----|-----|--|--|------------------------------|---|-----------------------|
| K0327.205 | M5  | 2,4 | 18 | 7  | 2,3 | 2   | 0,8 | 0,8 | 1,5 | 11   | 29                                       | 0,12                         | 0,08  | K0317.905             |
| K0327.206 | M6  | 2,7 | 20 | 7  | 2,5 | 2,5 | 1   | 1   | 2   | 14   | 37                                       | 0,45                         | 0,22  | K0317.906             |
| K0327.208 | M8  | 3,5 | 22 | 8  | 3   | 3   | 1,4 | 1,2 | 2,5 | 22   | 65                                       | 1,05                         | 0,37  | K0317.908             |
| K0327.210 | M10 | 4   | 22 | 9  | 3   | 3,5 | 1,4 | 1,6 | 3   | 19   | 70                                       | 1,30                         | 0,60  | K0317.910             |
| K0327.212 | M12 | 6   | 28 | 10 | 4   | 5   | 2   | 2   | 4   | 25   | 85                                       | 2,00                         | 1,30  | K0317.912             |
| K0327.216 | M16 | 7,5 | 32 | 14 | 5   | 6   | 2,5 | 2,5 | 5   | 60   | 150                                      | 3,90                         | 3,00  | K0317.916             |