

9500 SERIES

Pneumatic Swing Clamps | Product Overview

Features:

- Ideal for tight spaces with an arm motion that rotates at the top of the stroke
- Includes a rod weld cover to protect the rod throughout the entire stroke
- Can be mounted on any face with optional side flange mounting kit

Applications:

- Assembly
- Welding
- Light machining

Also Available:

See page 6 for mounting options

See page 7 for clamping arms

See page 40 for sensing options

Covered under one year or more U.S./International Patents

9522-2



9530-2



9540-2



9550-2



Shown with optional clamping arm.

Technical Information

Model	Swing Direction	Total Stroke [in.]mm	Stroke During Rotation [in.]mm	Vertical Clamping Stroke [in.]mm	Clamping Force @ [lbf.]N†	Bore Size [in.]mm	Air Consumption‡ dm³[in³]	Weight [lb.]kg	Replacement Seal Kit
9522-2L	LH	[0.50]		[0.50]	[34]	[0.86]	[0.004]	[0.68]	952292
9522-2R	RH	13		13	150	22	0,10	0,31	
9530-2L	LH	[0.79]	--	[0.79]	[76]	[1.26]	[0.010]	[1.25]	953092
9530-2R	RH				340	32	0,29	0,57	
9540-2L	LH	20		20	[123]	[1.57]	[0.016]	[1.98]	954092
9540-2R	RH				550	40	0,46	0,90	
9550-2L	LH				[196]	[1.97]	[0.026]	[3.33]	955092
9550-2R	RH				870	50	0,74	1,51	
9550-2GR									

† with standard clamping arm at 5bar [72psi]. ‡ Per double stroke at 5bar [72psi]

Operating Pressure Range: 3bar [40psig] to 8bar [120psig]

Maximum Operating Temperature: 60°C [140°F]

9500 SERIES

Pneumatic Swing Clamps | Dimensions

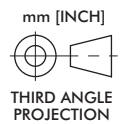
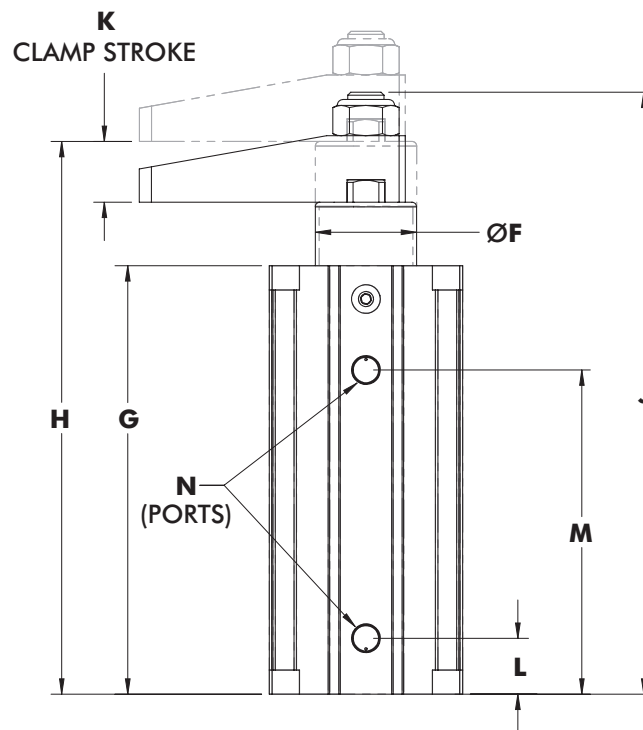
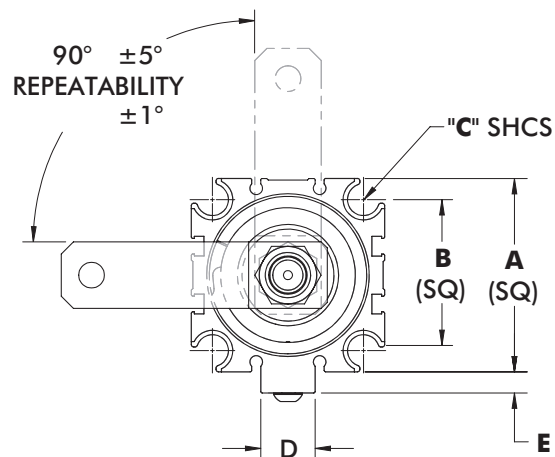
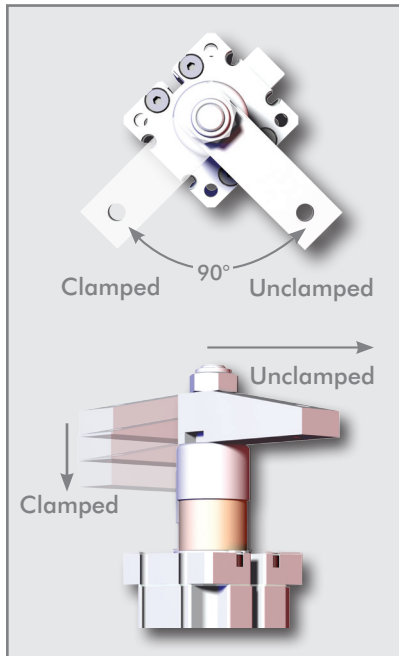

Shown with optional clamping arm.

Model	A	B	C	D	E	F	G	H	J	K	L	M	N
9522-2	[1.42] 36	[1.00] 25,4	M5 (#10)	--	--	[0.82] 21	[3.77] 95,8	[4.79] 121,8	[5.22] 132,7	[0.50] 13	[0.43] 11	[2.90] 73,8	M5
9530-2	[1.81] 46	[1.34] 34	M6 (1/4")	[0.55] 14	[0.16] 4	[0.96] 24,4	[4.48] 113,7	[6.09] 154,8	[6.54] 166	[0.79] 20	[0.61] 15,5	[3.39] 86,2	1/8NPT
9530-2G													
9540-2	[2.05] 52	[1.57] 40			[0.20] 5	[1.13] 28,7	[4.63] 117,6	[6.29] 159,7	[6.73] 170,9		[0.65] 16,5	[3.43] 87,1	1/8NPT
9540-2G													G-1/8
9550-2	[2.52] 64	[1.97] 50	M8 (5/16")	[0.71] 18	[0.28] 7	[1.32] 33,5	[5.58] 141,8	[7.20] 182,9	[7.85] 199,3		[0.73] 18,5	[4.22] 107,3	1/8NPT
9550-2G													G-1/8

9500 SERIES

Pneumatic Swing Clamps | Clamping Forces

Series 9522 Clamping Force

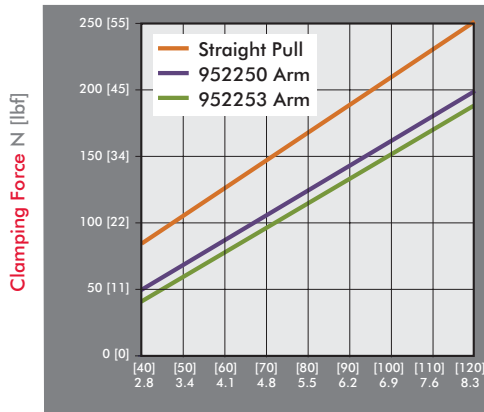

Inlet Pressure bar [PSI]

Series 9530 Clamping Force

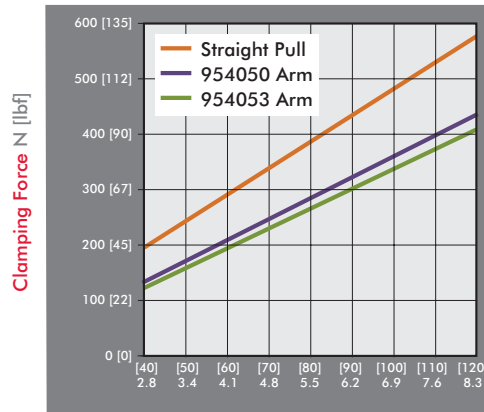

Inlet Pressure bar [PSI]

Series 9540 Clamping Force

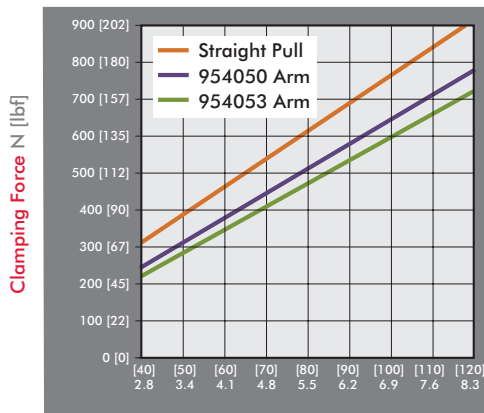

Inlet Pressure bar [PSI]

Series 9550 Clamping Force

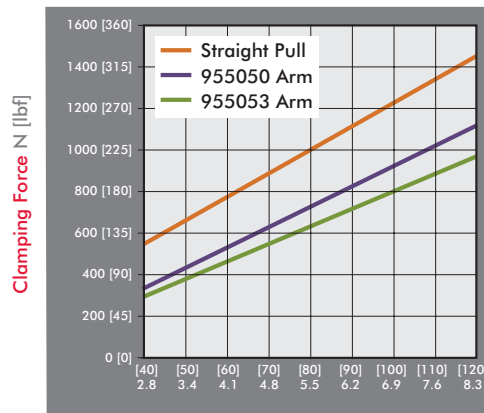

Inlet Pressure bar [PSI]

Guidelines

DE-STA-CO Pneumatic Swing Clamps are designed for long life when using standard clamping arms and spindles. In the event that a longer arm or additional weight is needed, please consult these charts for the allowable weight and length.

Example: 9522-2

At a weight of 80 gr, the maximum length of the arm is approximately 120mm.

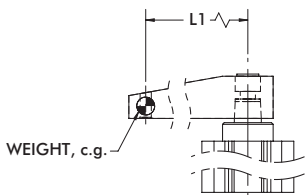

All data refers to an operating pressure of 5 bar (72psi) and an opening and closing time of 1 second.

9522-2 Clamp Arm Weight

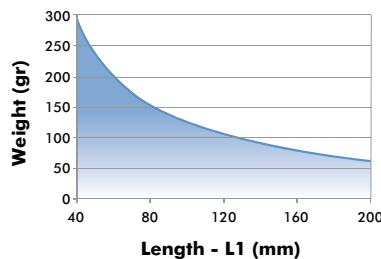

9530-2 Clamp Arm Weight

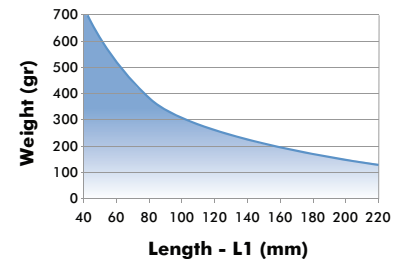

9540-2 Clamp Arm Weight

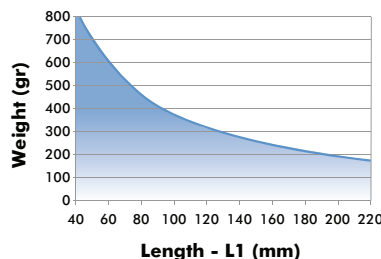

9550-2 Clamp Arm Weight

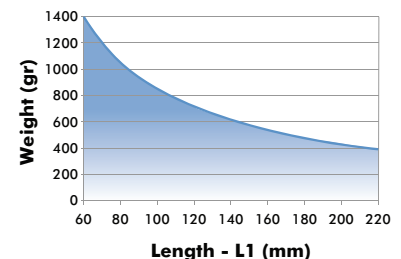

9500 SERIES

Pneumatic Swing Clamps | Mounting Accessories

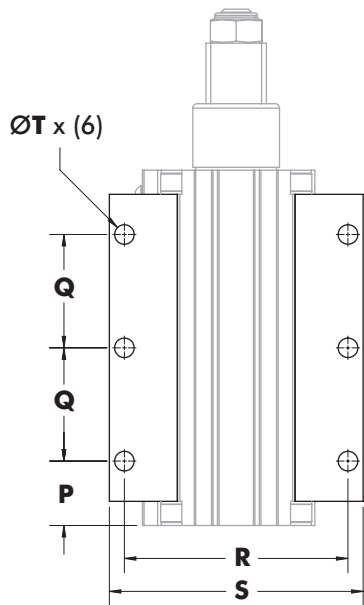
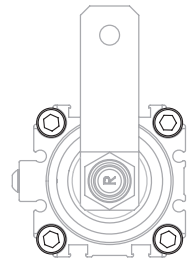
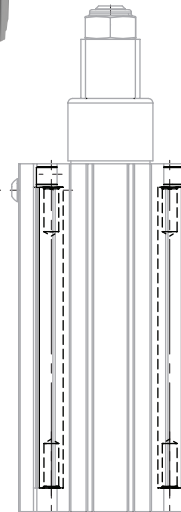
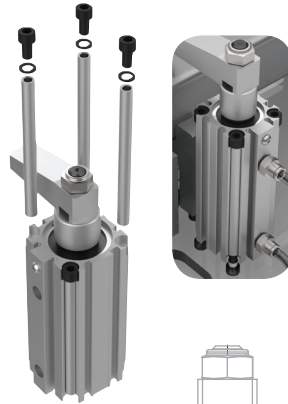
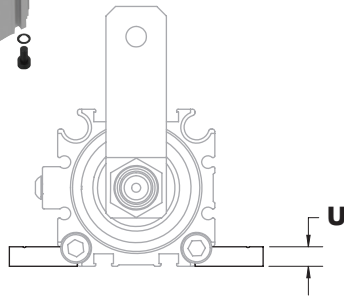
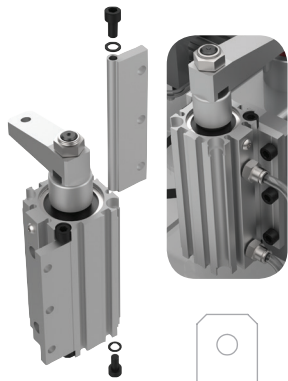
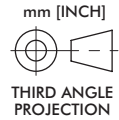

Side Flange Mounting

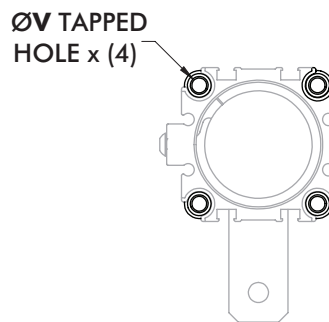

Tapped Hole Mount

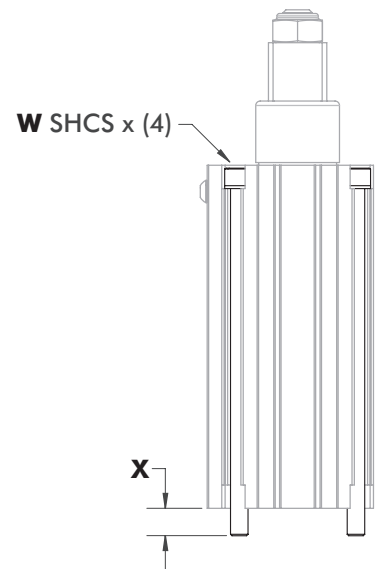

Standard Mount

Model	P	Q	R	S	T	U	V	W	X	Side Flange Kit	Tapped Hole Kit	Standard Mount Kit
9522-2	[0.41] 10,4		[1.91] 48,5	[2.26] 57,5	[0.22] 5,5	[0.22] 5,5	M5	M5x100	[0.36] 9.2	952260	952261	952262
9530-2	[0.76] 19,4	[1.48] 37,5	[2.68] 68	[3.07] 78			M6	M6x120	[0.52] 13.3	953060	953061	953062
9530-2G					[0.26] 6,5	[0.26] 6,5						
9540-2	[0.84] 21,3		[2.91] 74	[3.31] 84			M6	M6x120	[0.37] 9.4	954060	954061	
9550-2	[0.82] 20,9	[1.97] 50	[3.66] 93	[4.17] 106	[0.33] 8,5	[0.31] 8	M8	M8x150	[0.59] 15	955060	955061	955062
9550-2G												

Refer to NPN-9500-2 for mounting instructions

9500 SERIES

Pneumatic Swing Clamps | Clamping Arms

Features:

- Lightweight aluminum construction
- Designed for use with 9500-2 series clamps

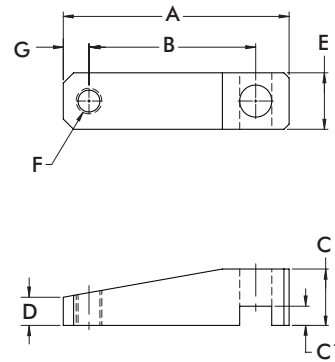
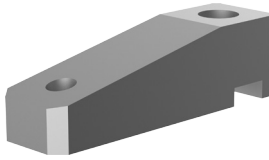

Part Number	Used with Model/series	A	B	C	C1	D	E	F	G	Weight [lbs] kg
9522150	9522-2R	[2.28] 58	[1.77] 45	[0.59]	[0.16]	[0.30]	[0.59]	M6	[0.20]	[0.06] 0,025
9522153	9522-2L	[3.07] 78	[2.56] 65	15	4	7.50	15		5	[0.08] 0,034
9540150	9530-2R/9530-2L	[2.76] 70	[1.97] 50	[0.79]	[0.18]	[0.39]	[0.79]	M8		[0.12] 0,054
9540153	9540-2R/9540-2L	[3.94] 100	[3.15] 80	20	4.57	10	20		[0.39]	[0.17] 0,079
9550150	9550-2R/9550-2L	[3.46] 88	[2.56] 65	[0.87]	[0.30]	[0.43]	[0.87]	M10	10	[0.18] 0,081
9550153	9550-2GR/9550-2GL	[4.45] 113	[3.54] 90	22	7.5	11	22			[0.23] 0,11

PNEUMATIC SWING CLAMPS

Notes

