

# Height adjustment bolts

METRIC  
Parts

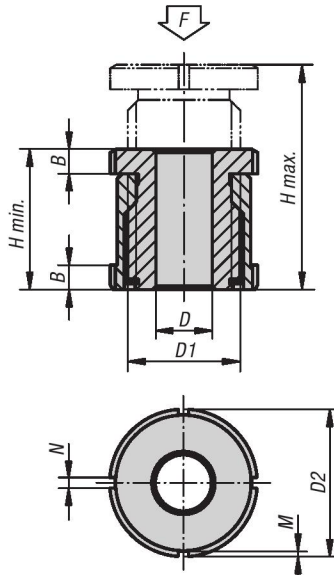

## KIPP Height adjustment bolts, metric

Item No.	Material	D	for screw	D1	D2	H min.	H max.	B	N	M	F kN
K0692.01504	steel	4,5	M4	M15x1	25	28	43	5	4	2	40
K0692.01505	steel	5,5	M5	M15x1	25	28	43	5	4	2	40
K0692.01506	steel	6,6	M6	M15x1	25	28	43	5	4	2	40
K0692.02006	steel	6,6	M6	M20x1	32	35	55	6	4	2	65
K0692.02008	steel	9	M8	M20x1	32	35	55	6	4	2	65
K0692.02010	steel	11	M10	M20x1	32	35	55	6	4	2	65
K0692.02510	steel	11	M10	M30x1,5	45	42	67	7	5	2	120
K0692.02512	steel	13,5	M12	M30x1,5	45	42	67	7	5	2	120
K0692.02516	steel	17,5	M16	M30x1,5	45	42	67	7	5	2	120
K0692.03216	steel	17,5	M16	M40x1,5	58	54	86	9	6	2,5	210
K0692.03220	steel	22	M20	M40x1,5	58	54	86	9	6	2,5	210
K0692.03224	steel	26	M24	M40x1,5	58	54	86	9	6	2,5	210
K0692.04020	steel	22	M20	M50x1,5	70	66	106	11	6	2,5	330
K0692.04024	steel	26	M24	M50x1,5	70	66	106	11	6	2,5	330
K0692.04030	steel	33	M30	M50x1,5	70	66	106	11	6	2,5	330
K0692.015041	stainless steel	4,5	M4	M15x1	25	28	43	5	4	2	27,1
K0692.015051	stainless steel	5,5	M5	M15x1	25	28	43	5	4	2	27,1
K0692.015061	stainless steel	6,6	M6	M15x1	25	28	43	5	4	2	27,1
K0692.020061	stainless steel	6,6	M6	M20x1	32	35	55	6	4	2	43,4
K0692.020081	stainless steel	9	M8	M20x1	32	35	55	6	4	2	43,4
K0692.020101	stainless steel	11	M10	M20x1	32	35	55	6	4	2	43,4
K0692.025101	stainless steel	11	M10	M30x1,5	45	42	67	7	5	2	84
K0692.025121	stainless steel	13,5	M12	M30x1,5	45	42	67	7	5	2	84
K0692.025161	stainless steel	17,5	M16	M30x1,5	45	42	67	7	5	2	84
K0692.032161	stainless steel	17,5	M16	M40x1,5	58	54	86	9	6	2,5	148
K0692.032201	stainless steel	22	M20	M40x1,5	58	54	86	9	6	2,5	148
K0692.032241	stainless steel	26	M24	M40x1,5	58	54	86	9	6	2,5	148
K0692.040201	stainless steel	22	M20	M50x1,5	70	66	106	11	6	2,5	225
K0692.040241	stainless steel	26	M24	M50x1,5	70	66	106	11	6	2,5	225
K0692.040301	stainless steel	33	M30	M50x1,5	70	66	106	11	6	2,5	225



### Material:

Steel 1.7225.

Stainless steel 1.4305.

### Type:

Steel zinc plated, blue chromate;  
stainless steel natural finish

### Part Number Example:

K0692.01505

### Note:

The height adjustment bolts are used when dealing with the positioning and alignment of motors, motor units, drive components and production lines. They are characterised by their large travel of 15 mm to 40 mm. Other sizes available on request.

