

MANUAL CLAMPING ACCESSORIES

Manual Clamping Accessory Overview



Flat-Tip Bonded
Neoprene Spindle
– Inch



Large Diameter
Padded Swivel Foot
Spindle – Inch



Neoprene Caps



Bolt Retainers



Flat-Tip Bonded
Neoprene Spindle
– Metric



Swivel Foot
Spindle



Special Neoprene Caps

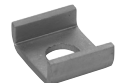
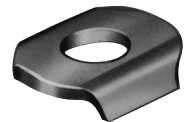

Flanged Washers



Round Bonded
Neoprene Spindle
– Metric



Hex Head
Spindle



Polyurethane Caps



Cone-Tip Bonded
Neoprene Spindle
– Metric



Plunger-matic
Assemblies



Cone-Tip
Polyurethane Caps

SPINDLES

Manual Clamping Accessories | Technical Information, Dimensions

Flat-Tip Bonded Neoprene Spindle – Inch

- Black neoprene, hardness: 70-80 Shore A
- Temperature Range: -20°C to 100°C [-22°F to 212°F]
- Oil resistant, LABS (silicone) free
- Includes jam nuts
- Stainless steel versions available upon request

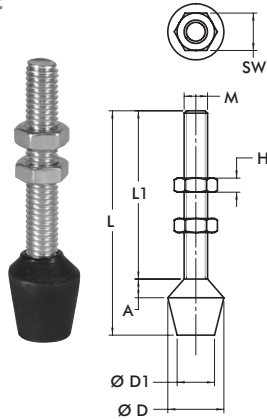

Part No.	M	L	L1	SW	H	A	ØD	ØD1
102208	#8-32	[1.25] 31,8	[0.94] 23,8	[0.34] 8,7	[0.13] 3,2	[0.06] 1,6	[0.56] 14,3	[0.44] 11,1
105208		[1.00] 25,4	[0.69] 17,4					
201208	#10-32	[1.38] 35,1	[1.01] 25,5	[0.38] 9,5		[0.13] 3,2		
202208	1/4-20	[1.63] 41,4	[1.08] 27,4	[0.44] 11,1	[0.16] 4	[0.12] 3	[0.63] 16	[0.47] 12
215208		2.13 54,1	[1.58] 40,1					
424208		[1.50] 38,1	[1.12] 28,5					
431208		[1.00] 25,4	[0.62] 15,8					
225208	5/16-18	[2.25] 57,2	[1.54] 39,1	[0.50] 12,7	[0.19] 4,8		[0.83] 21	[0.55] 14
507208		[3.00] 76,2	[2.29] 58,2					
240208	3/8-16	[3.25] 82,6	[2.31] 58,5	[0.56] 14,3	[0.22] 5,6	[0.20] 5	[1.02] 26	[0.79] 20
527208		[3.50] 88,9	[2.50] 63,5					
235208		[5.75] 146,1	[4.77] 121,1					
247208	1/2-13	[3.87] 98,3	[2.73] 69,3	[0.75] 19,1	[0.31] 7,9	[0.28] 7	[1.18] 30	[0.95] 24
267208	5/8-11	[5.00] 127	[3.63] 92,1	[0.94] 23,8	[0.38] 9,5	[0.38] 9,5	[1.38] 35,1	[1.00] 25,4

Flat-Tip Bonded Neoprene Spindle – Metric

- Red neoprene, hardness: 80-85 Shore A
- Temperature Range: -20°C to 100°C [-22°F to 212°F]
- Oil resistant, LABS (silicone) free
- Includes jam nuts

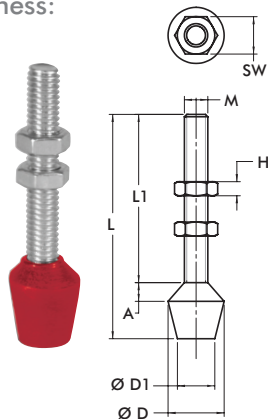

Part No.	M	L	L1	SW	H	A	ØD	ØD1
431208-M	M6	[1.00] 25,4	[0.6] 15,8	[0.39] 10	[0.13] 3,2	[0.13] 3,3	[0.66] 16,8	[0.66] 16,8
424208-M		[1.63] 41,3	[1.25] 31,7					
202208-M		[1.73] 44	[1.18] 30					
215208-M		[2.13] 54	[1.57] 40					
225208-M	M8	[2.09] 53	[1.38] 35	[0.51] 13	[0.16] 4	[0.20] 5	[0.83] 21	[0.55] 14
2007208-M		[2.48] 63	[1.77] 45					
507208-M		[3.27] 83	[2.56] 65					
240208-M	M10	[3.11] 79	[2.17] 55	[0.67] 17	[0.20] 5	[1.02] 26	[0.78] 20	
235208-M		[4.72] 120	[3.74] 95					
247208-M	M12	[4.02] 102	[2.87] 73	[0.75] 19	[0.24] 6	[0.28] 7	[1.18] 30	[0.94] 24

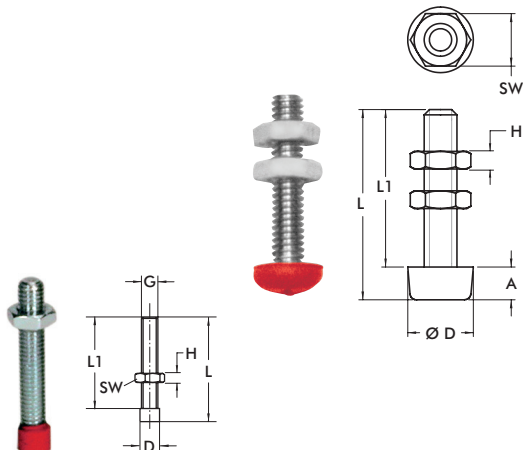

Part No.	M	L	L1	SW	H	A	ØD
205208-M	M4	[0.87] 22	[0.79] 20	[0.28] 7	[0.09] 2,2	[0.11] 2,8	[0.32] 8
201208-M		[1.26] 32	[1.18] 30				
305208-M	M5	[1.14] 29	[0.98] 25	[0.32] 8	[0.11] 2,7	[0.20] 5	[0.39] 10
213208-M		[1.34] 34	[1.18] 30				
2013208-M		[1.54] 39	[1.38] 35				
307208-M	M8	[1.69] 43		[0.51] 13	[0.16] 4	[0.35] 9	[0.75] 19

Part No.	D	L	L1	ØG
213208-M-L ⓘ	[0.24] 6	[1.34] 34	[1.18] 30	M5

ⓘ Item is available upon request.

Manual Clamping Accessories | Technical Information, Dimensions

Cone-Tip Bonded Neoprene Spindle – Inch

- Black neoprene, hardness: 70-80 Shore A
- Temperature Range: -20°C to 100°C [-22°F to 212°F]
- Oil resistant, LABS (silicone) free
- Includes jam nuts

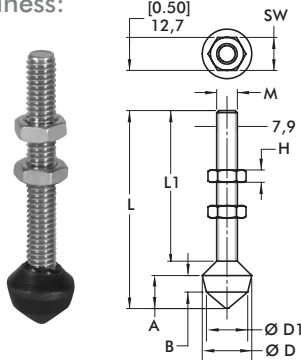

Part No.	M	L	L1	SW	H	A	B	ØD	ØD1
305208	#10-32	[1.50] 38,1	[1.00] 25,4	[0.38] 9,5	[0.13] 3,3	[0.38] 9,5	[0.19] 4,8	[0.56] 14,2	[0.44] 11,2
213208	1/4-20	[2.25] 57,2	[1.56] 39,6	[0.44] 11,2	[0.16] 4,0				
509208	5/16-18	[3.00] 76,2	[2.28] 57,9	[0.50] 12,7	[0.19] 4,8	[0.50] 12,7	[0.25] 6,4	[0.75] 19,1	[0.63] 16
519208		[5.50] 139,7	[4.75] 120,7						
210208	3/8-16	[3.50] 88,9	[2.50] 63,5	[0.56] 14,2	[0.23] 5,8	[0.75] 19,1	[0.41] 10,4	[0.88] 22,4	[0.75] 19,1

Large Diameter Padded Swivel Foot Spindle-Inch

- White neoprene, hardness: 70-80 Shore A
- Temperature Range: -40°C to 105°C [-40°F to 220°F]
- Non-marking neoprene
- Includes jam nuts

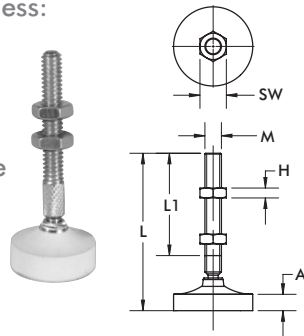

Part No.	M	L	L1	SW	H	A	ØD	Swivel Angle
207209	1/4-20	[2.56] 65	[1.56] 39,6	[0.44] 11,2	[0.16] 4		[1.00] 25,4	14°
507209	5/16-18	[2.98] 75,7	[1.94] 49,3	[0.50] 12,7	[0.19] 4,8	[0.31] 8	[1.50] 38,1	24°
210209	3/8-16	[3.56] 90,4	[2.44] 62	[0.56] 14,2	[0.23] 5,8		[2.00] 50,8	26°

Plunger-matic Assemblies

- For use with Straight Line Action clamps
- Internal compression spring compensates for variations in material thickness
- Zinc plated
- Includes jam nut

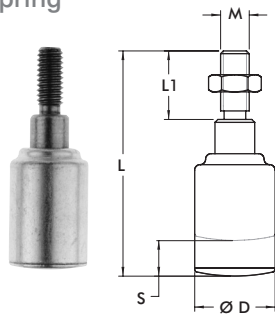

Part No.	M	L	L1	ØD	Max. Compression S	Spring Constant [lb./in] N/mm	Max. Force [lb.] N
905	5/16-18	[2.50] 63,5	[0.75] 19,1	[0.88] 22,2	[0.19] 4,8	[750] 131	[135] 600
905-M							
920	3/8-16	[3.63] 92,2	[1.13] 28,6		[0.38] [9,6]	[822] 144	[308] 1370
920-M							

Swivel Foot Spindle

- Includes jam nuts

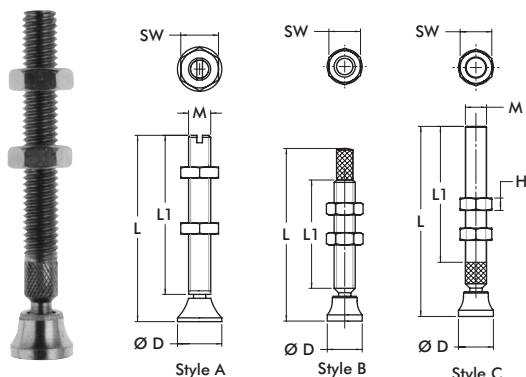

Part No.	M	Style	L	L1	SW	H	ØD	Swivel Angle
207206-M	M6	A	[2.44] 62	[2.13] 54	[0.39] 10	[0.13] 3,2	[0.47] 12	30°
507206-M			M8	[2.87] 73	[2.46] 62,5	[0.51] 13	[0.16] 4	
468206-M	M10	B	[3.00] 76,2	[2.00] 50,8	[0.67] 17	[0.20] 5	[0.79] 20	24°
210206-M			M12	[3.31] 84				
250206-M	M12	A	[4.72] 120	[4.13] 105	[0.75] 19	[0.24] 6	[0.98] 25	30°
207206			1/4-20	[2.38] 60,5	[1.56] 39,6	[0.44] 11,2	[0.16] 4	
507206	5/16-18	C	[2.75] 69,9	[1.94] 49,3	[0.50] 12,7	[0.19] 4,8	[0.56] 14,2	24°
468206			3/8-16	[3.06] 77,7	[1.92] 48,8	[0.56] 14,2	[0.23] 5,8	
210206	1/2-13	C	[3.38] 85,9	[2.41] 61,2	[0.75] 19,1	[0.31] 7,9	[1.00] 25,4	26°
250206			M10	[4.63] 117,6				

SPINDLES

Manual Clamping Accessories | Technical Information, Dimensions

Hex Head Spindle – Stainless Steel

- Includes Plain hexagonal head
- Includes Fully threaded
- Includes Stainless steel, type 303
- Includes Includes jam nuts

Part No.	M	L	L1	SW	H	Part No.	M	L	L1	SW	H
205943-M	M4	[0.89] 22	[0.79] 20	[0.28] 7	[0.09] 2,2	205943	#8-32	[0.86] 21,8	[0.75] 19,1	[0.25] 6,4	[0.13] 3,2
201943-M	M5	[1,32] 33,5	[1.18] 30	[0.31] 8	[0.11] 2,7	201943	#10-32	[1,37] 34,8	[1,37] 34,8	[0.31] 8	
202943-M	M6	[1.73] 42,4	[1.57] 40	[0.39] 10	[0.13] 3,2	202943	1/4-20	[1.67] 42,4	[1.50] 38,1	[0.44] 11,1	[0.16] 4
207943-M	M8	[2.77] 70,3	[2.56] 65	[0.51] 13	[0.16] 4	207943	5/16-18	[2.72] 69	[2.50] 63,5	[0.50] 12,7	[0.19] 4,8
237943-M	M10	[3.00] 76,4	[2.76] 70	[0.67] 17	[0.20] 5	237943	3/8-16	[2.75] 69,9	[2.50] 63,5	[0.56] 14,2	[0.22] 5,6
245943-M	M12	[2.87] 73	[2.56] 65	[0.75] 19	[0.24] 6	245943	1/2-13	[2.72] 69	[2.38] 60,5	[0.75] 19,1	[0.31] 8

Hex Head Spindle

- Plain hexagonal head
- Fully threaded
- Zinc plated
- Includes jam nuts

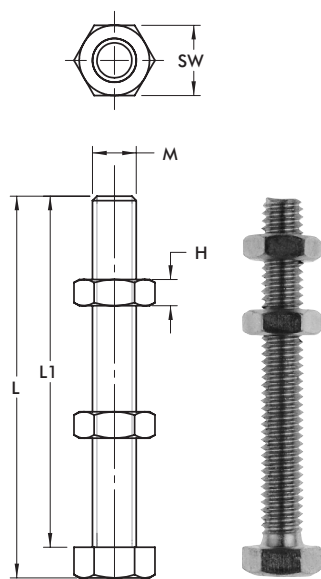

Part No.	M	L	L1	SW	H	Part No.	M	L	L1	SW	H
205203-M	M6	[1.93] 49	[1.77] 45	[0.39] 10	[0.13] 3,2	205203	1/4-20	[1.92] 48,8	[1.75] 44,5	[0.44] 11,2	[0.16] 4
461203-M	M8	[1.20] 30,5	[0.98] 25	[0.51] 13	[0.16] 4	202203	5/16-18	[3.17] 80,5	[3.00] 76,2	[0.50] 12,7	[0.19] 4,8
207203-M		[2.97] 75,5	[2.76] 70			461203		[1.22] 31	[1.00] 25,4		
491203-M	M10	[1.85] 47	[1.57] 40	[0.67] 17	[0.20] 5	441203	3/8-16	[1.97] 50	[1.75] 44,5	[0.56] 14,2	[0.23] 5,8
210203-M		[3.03] 77	[2.76] 70			207203		[2.72] 69,1	[2.50] 63,5		
240203-M		[4.21] 107	[3.94] 100			491203		[1.75] 44,5	[1.50] 38,1		
220203-M	M12	[3.46] 88	[3.15] 80	[0.75] 19	[0.24] 6	210203	1/2-13	[3.00] 76,2	[2.75] 69,9	[0.75] 19,1	[0.31] 7,9
267203-M	M16	[5.12] 130	[4.72] 120	[0.94] 24	[0.28] 7	240203		[4.25] 108	[4.00] 101,6		
105203*	#8-32	[0.86] 21,8	[0.75] 19,1	[0.25] 6,4	[0.13] 3,3	527203	5/8-11	[5.25] 133,4	[5.00] 127	[0.38] 9,5	[0.38] 9,5
305203	#10-32	[1.12] 28,4	[1.00] 25,4	[0.31] 8		325203		[2.84] 72,1	[2.50] 63,5	[0.75] 19,1	[0.31] 7,9
						220203		[3.34] 84,8	[3.00] 76,2		
						250203		[4.42] 101,6	[4.00] 101,6	[0.38] 9,5	[0.38] 9,5

*Material: nylon

SPINDLE CAPS

Manual Clamping Accessories | Technical Information, Dimensions

Neoprene Caps

- Slip on head of hex-head spindles
- Hardness: 60-70 Shore A
- Temperature range:
-40°C to 105°C [-40°F to 220°F]

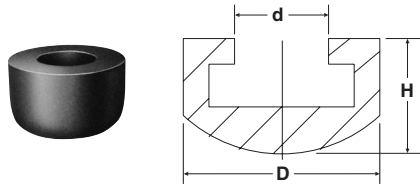

Part No.	D	d	H	For Spindle Diameter
215119	[0.63] 16	[0.25] 6,35	[0.44] 11,1	M6 or 1/4
225119	[0.75] 19,1	[0.31] 8	[0.50] 12,7	M8 or 5/16
235119	[0.88] 22,3	[0.38] 9,7	[0.53] 13,5	3/8

Special Neoprene Caps

- Slip on threaded spindle rod
- Hardness: 60-70 Shore A
- Temperature range:
-40°C to 105°C [-40°F to 220°F]

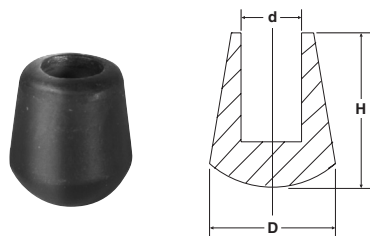

Part No.	D	d	H	For Spindle Diameter
424107	[0.44] 11,1	[0.22] 5,6	[0.44] 11,1	M6 or 1/4
235110	[0.72] 18,3	[0.34] 8,6	[0.88] 22,3	M10 or 3/8

Polyurethane Caps

- Flat tip, internally threaded
- Hardness: 80 Shore A
- Temperature range:
-70°C to 95°C [-90°F to 200°F]

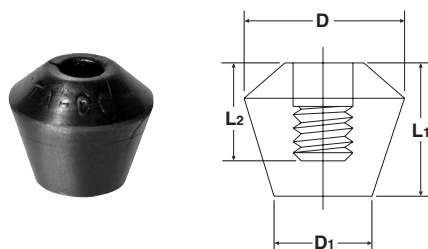

Part No.	D	D1	L1	L2	For Spindle Diameter
215219					1/4-20
215219-M	[0.79] 20	[0.50] 12,7	[0.69] 17,5	[0.50] 12,7	M6 x 1.0
225219					5/16-18
225219-M					M8 x 1.25
235219	[0.81] 20,5	[0.63] 16	[0.88] 22,3	[0.63] 16	3/8-16
235219-M					M10 x 1.5

Polyurethane Caps – Cone-tip

- Cone tip, internally threaded
- Hardness: 80 Shore A
- Temperature range:
-70°C to 95°C [-90°F to 200°F]

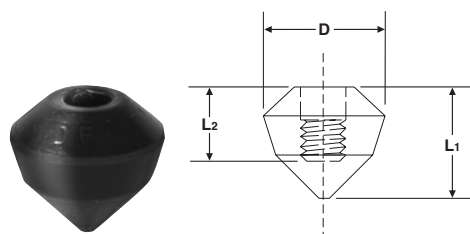

Part No.	D	L1	L2	For Spindle Diameter
215319		[0.75] 19,1	[0.50] 12,7	1/4
225319	[0.81] 20,5			5/16
235319		[0.94] 23,9	[0.63] 16	3/8

BOLT RETAINERS, WASHERS

Manual Clamping Accessories | Technical Information, Dimensions

Bolt Retainers –

- For use with clamps featuring U-bar and open bar clamping arms

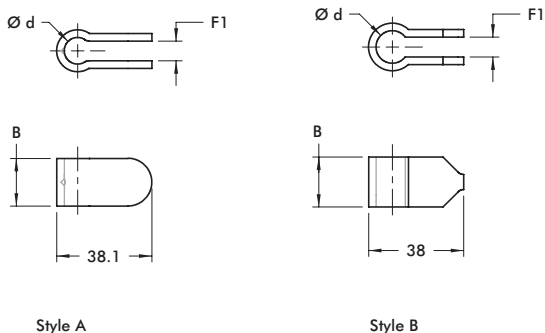

Part No.	A	B	Ød	F1	For Spindle Diameter	Style
207105	[1.25] 31,8	[0.63] 16	[0.33] 8,4	[0.25] 6,4	M8 or 5/16	A
207105-M	[1.26] 32		[0.32] 8,2	[0.24] 6		B
210114	[1.50] 38,1	[0.75] 19,1	[0.53] 13,5	[0.31] 8	M10 or 3/8	A
210114-M	[1.49] 38	[0.78] 20	[0.51] 13			B
247110	[1.63] 41,4	[0.88] 22,3	[0.56] 14,2	[0.38] 9,7	M12 or 1/2	A
247110-M	[1.61] 41	[0.87] 22,2	[0.57] 14,4			B
250121	[1.88] 47,8	[1.00] 25,4	[0.64] 16,3		M12 or 1/2	A
2002115-E	[0.97] 24,6	[0.50] 12,7	[0.26] 6,6	[0.23] 5,8	M6 or 1/4	B
2007115-E	[1.26] 32	[0.75] 19,1	[0.34] 8,6		M8 or 5/16	
2010115-E	[1.58] 40,1	[1.13] 28,7	[0.41] 10,4	[0.32] 8,1	M10 or 3/8	

Flanged Washers –

- For use with clamps featuring U-bar and open bar clamping arms
- Zinc plated

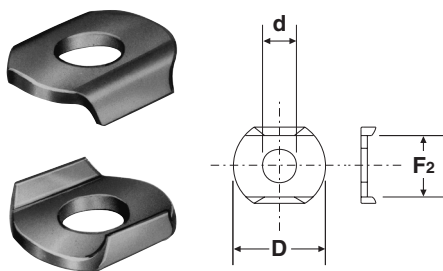

Part No.	ØD	Ød	F2	For Spindle Diameter
105106	[0.44] 11,2	[0.17] 4,3	[0.33] 8,3	M4 or #8
102111	[0.56] 14,2	[0.20] 5,1	[0.38] 9,6	M5 or #10
215105	[0.69] 17,5	[0.26] 6,7	[0.50] 12,7	M6 or 1/4
507107	[0.88] 22,4	[0.33] 8,4	[0.59] 15	M8 or 5/16
235106	[1.00] 25,4	[0.41] 10,5	[0.75] 19,1	M10 or 3/8
247109	[1.26] 32	[0.53] 13,5	[0.91] 23,2	M12 or 1/2
267102	[1.44] 36,5	[0.66] 16,8	[1.03] 26,2	M16 or 5/8

Flanged Washers-Stainless Steel

- For use with clamps featuring U-bar and open bar clamping arms

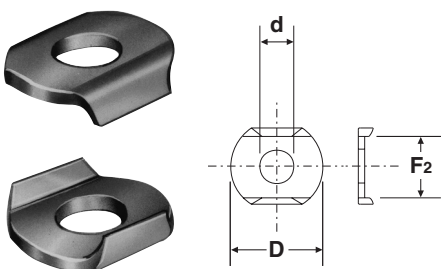

Part No.	ØD	Ød	F2	For Spindle Diameter
105906	[0.44] 11,2	[0.17] 4,3	[0.33] 8,3	M4 or #8
102911	[0.56] 14,2	[0.20] 5,1	[0.38] 9,6	M5 or #10
215905	[0.69] 17,5	[0.26] 6,7	[0.50] 12,7	M6 or 1/4
507907	[0.88] 22,4	[0.33] 8,4	[0.60] 15,2	M8 or 5/16
235906	[1.00] 25,4	[0.41] 10,5	[0.75] 19,1	M10 or 3/8
247909	[1.26] 32	[0.53] 13,5	[0.91] 23,2	M12 or 1/2
267902	[1.44] 36,6	[0.66] 16,8	[1.03] 26,2	M16 or 3/8

ADAPTERS & EXTENSIONS

Manual Clamping Accessories | Product Overview

Features:

- Provides flexible adjustment of length and height
- Mounts to manual clamp models that feature open clamping arms
- Lightweight aluminum

Application Areas:

- Checking fixtures
- Areas requiring multiple clamping points

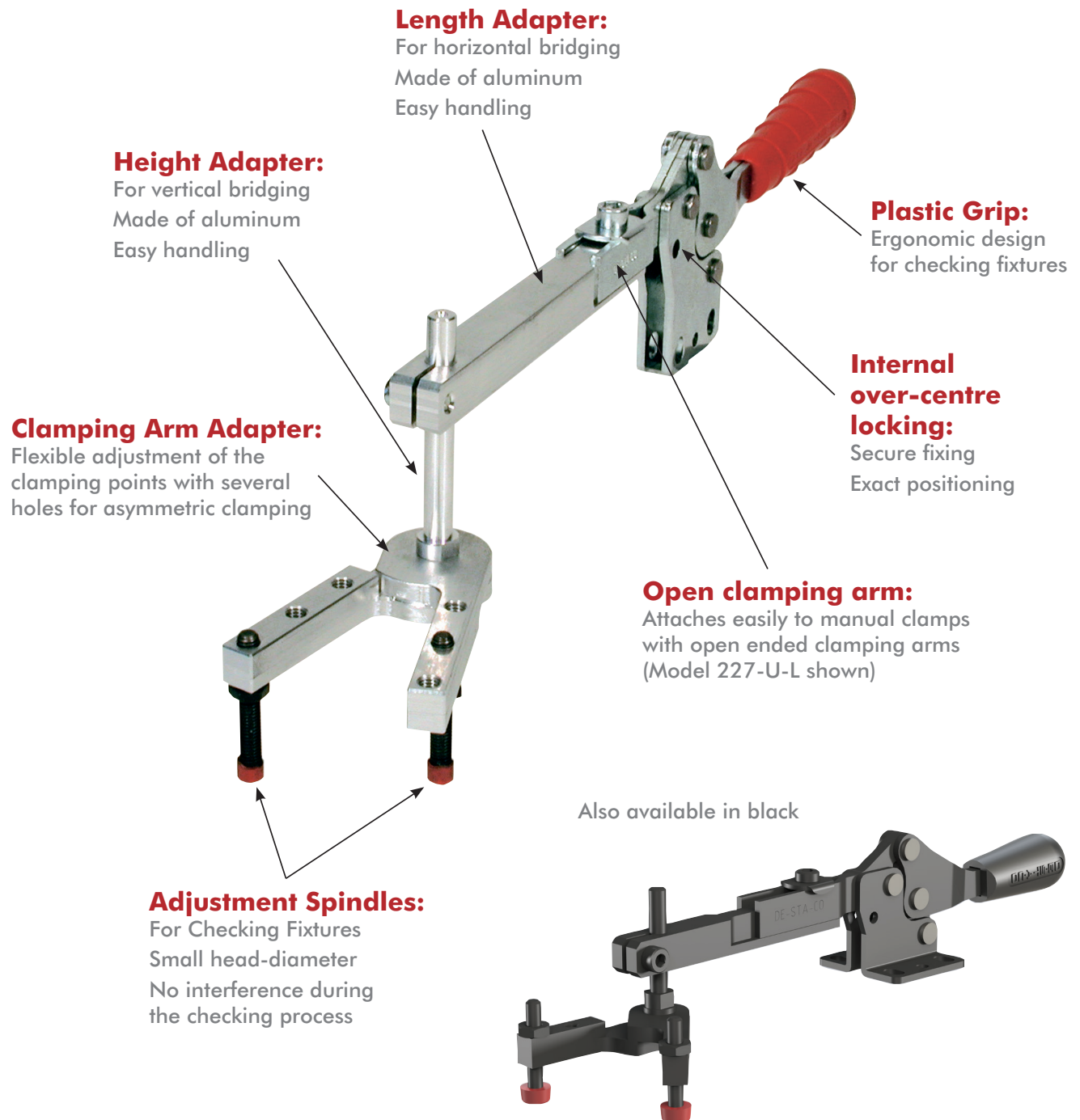

ADAPTERS & EXTENSIONS

Manual Clamping Accessories | Dimensions

Length Adapter

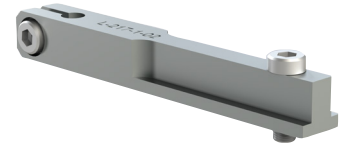
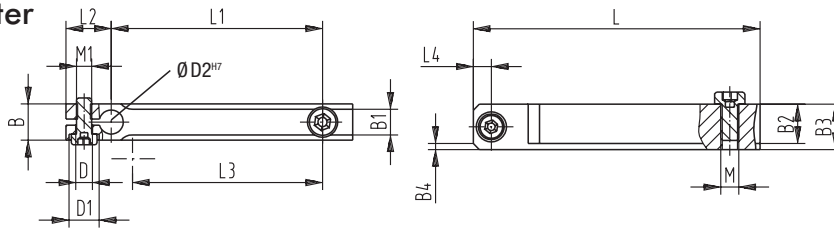

Model no.	Length adapter	B	B1 +0, -1	B2	B3	B4	DØ	D1 Ø	D2 ^{H7}	L	L1 ±0,2	L2	L3	L4	M	M1
213-U-L / 213-UB-L	L-213-1-01	[0.39] 10	[0.22] 5,5	[0.31] 8	[0.39] 10	2x 45°	[0.22] 5,5	--		[1.97] 50	[1.18] 30	[0.47] 12	[0.79] 20	[0.20] 5	M4	M5
2013-U / 2013-UB	L-213-1-02									[3.54] 90	[2.76] 70					
2013-UR / 2013-UBR	L-213-1-02															
202-U-L / 202-UB-L	L-217-1-01								[0.24] 6	[2.17] 55	[1.18] 30		[1.30] 33			
217-U-L / 217-UB-L	L-217-1-01															
2002-U-L / 2002-UB-L	L-217-1-02		[0.26] 6,5	[0.35] 9	[0.47] 12	2x 45°	[0.22] 5,5			[3.74] 95	[2.76] 70				M5	M5
2017-U / 2017-UB	L-217-1-03									[5.31] 135	[4.33] 110		[1.89] 48			
2017-UR / 2017-UBR	L-217-1-03															
207-U-L / 207-UB-L	L-227-1-01	[0.47] 12						[0.39] 10		[2.17] 55	[1.18] 30	[0.59] 15	[1.30] 33	[0.24] 6		
227-U-L / 227-UB-L	L-227-1-02									[3.74] 95	[2.76] 70					
2007-U-LS / 2007-U-LS	L-227-1-03		[0.33] 8,5	[0.51] 13	[0.59] 15	2x 45°	[0.22] 5,5		[0.31] 8	[5.31] 135	[4.33] 110		[2.87] 73		M6	M5
2027-U / 2027-UB	L-227-1-03															
2027-UR / 2027-UBR	L-227-1-04									[6.89] 175	[5.91] 150					

Ⓜ Available upon request.

Also available in Black. Add **-BLK** to part number.

Height Adapter

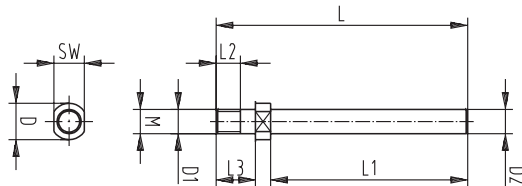

Model no.	Height adapter	DØ	D1 Ø _{f7}	D2 _{f7}	L	L1	L2	L3	SW	M
213-U-L / 213-UB-L	L-213-2-01		[0.20] 5	[0.24] 6	[2.05] 52	[1.38] 35				M5
2013-U / 2013-UB	L-213-2-02				[3.23] 82	[2.56] 65				
2013-UR / 2013-UBR	L-213-2-02									
202-U-L / 202-UB-L	L-217-2-01	[0.39] 10			[2.05] 52	[1.38] 35		[0.47] 12	[0.31] 8	M6
217-U-L / 217-UB-L	L-217-2-01		[0.24] 6	[0.24] 6						
2002-U-LS / 2002-UB-LS	L-217-2-02				[3.23] 82	[2.56] 65	[0.31] 8			
2017-U / 2017-UB	L-217-2-02									
2017-UR / 2017-UBR	L-217-2-02									
207-U-L / 207-UB-L	L-227-2-01				[2.09] 53	[1.38] 35		[0.51] 13	[0.39] 10	M8
227-U-L / 227-UB-L	L-227-2-01		[0.31] 8	[0.31] 8						
2007-U-LS / 2007-U-LS	L-227-2-02	[0.31] 8		[0.31] 88	[3.23] 82	[2.56] 65				
2027-U / 2027-UB	L-227-2-02									
2027-UR / 2027-UBR	L-227-2-02									

Ⓜ Available upon request.

Also available in Black. Add **-BLK** to part number.

ADAPTERS & EXTENSIONS

Manual Clamping Accessories | Dimensions

Clamping Arm Adapter

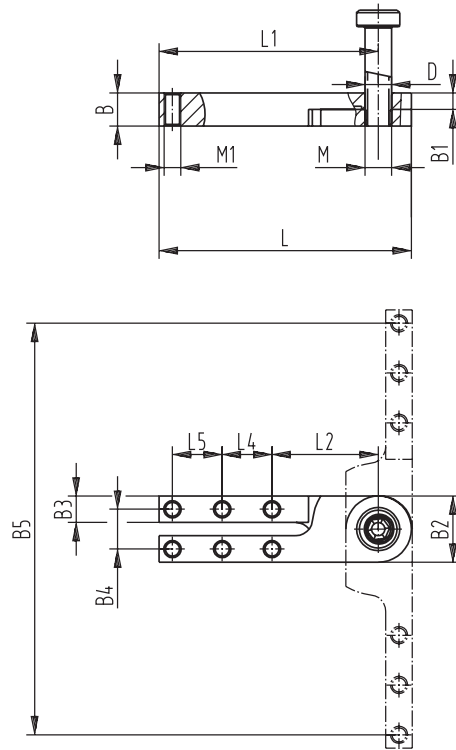

Model no.	Clamping arm adapter	B	B1	B2	B3	B4	B5	DØ _{H7}	L	L1	L2	L4	L5	L6	M	M1
213-U-L / 213-UB-L 2013-U / 2013-UB 2013-UR / 2013-UBR	L-213-3-01 ⓘ							[0.20] 5							M5	M5
202-U-L / 202-UB-L 217-U-L / 217-UB-L 2002-U-LS / 2002-UB-LS 2017-U / 2017-UB 2017-UR / 2017-UBR	L-217-3-01 ⓘ	[0.39] 10	[0.20] 5	[0.79] 20	[0.31] 8	[0.47] 12	[3.70] 94	[0.24] 6	[2.40] 61	[2.01] 51					M6	M5
207-U-L / 207-UB-L 227-U-L / 227-UB-L 2007-U-LS / 2007-UB-LS 2027-U / 2027-UB 2027-UR / 2027-UBR	L-227-3-01 ⓘ						4.88 124	[0.31] 8	[2.99] 76	[2.60] 66				[0.59] 15	M8	M5

ⓘ Available upon request. Also available in Black. Add **-BLK** to part number.

ADAPTERS & EXTENSIONS

Manual Clamping Accessories | Dimensions

Arm Extension:

- Easily cut to length
- Drilled & tapped for spindle attachment

Note: adding arm extension will reduce the clamp's holding capacity. Refer to Technical Appendix for details

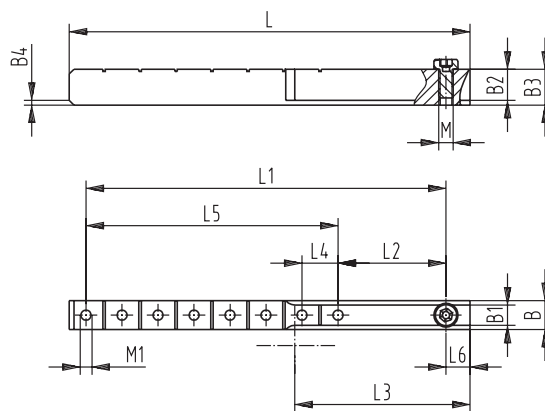
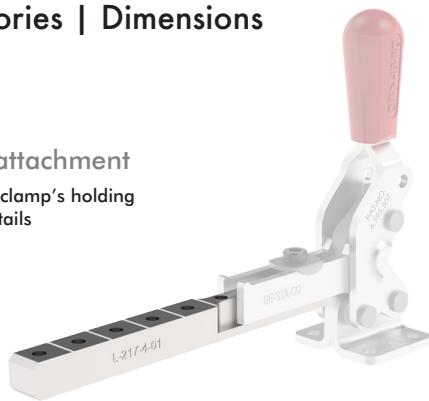

Model no.	Extension link	B	B1 +0, -1	B2	B3	B4	L ±0,2	L1	L2	L3	L4	L5	L6	M	M1
213-U-L / 213-UB-L 2013-U / 2013-UB 2013-UR / 2013-UBR	L-213-4-01 ⓘ	[0.39] 10	[0.22] 5,5	[0.31] 8	[0.39] 10	2x 45°	[2.95] 75	[2.36] 60	[0.94] 24	[0.79] 20	[0.47] 12	[1.42] 36	[0.31] 8	M4	M5
202-U-L / 202-UB-L 217-U-L / 217-UB-L 2002-U-LS / 2002-UB-LS 2017-U / 2017-UB 2017-UR / 2017-UBR	L-217-4-01 ⓘ		[0.26] 6,5	[0.35] 9	[0.47] 12	2x 45°	[5.00] 127	[4.33] 110	[1.38] 35	[1.89] 48		[2.95] 75	[0.39] 10	M5	M5
207-U-L / 207-UB-L 227-U-L / 227-UB-L 2007-U-LS / 2007-UB-LS 2027-U / 2027-UB 2027-UR / 2027-UBR	L-227-4-01 ⓘ	[0.47] 12		[0.51] 13	[0.59] 15	2x 45°	[6.57] 167	[5.91] 150	[1.77] 45	[2.87] 73	[0.59] 15		[4.13] 105	[0.39] 10	M6 M5

ⓘ Available upon request. Also available in Black. Add **-BLK** to part number.

Cross Arm Set

- 1 x cross arm
- 2 x adjustment spindles with neoprene thrust pads vulcanized, resin-free, inc.
- 2 x fastening nuts
- 4 x flange washers
- 1 x screw incl. 1 x fastening nut, self-locking

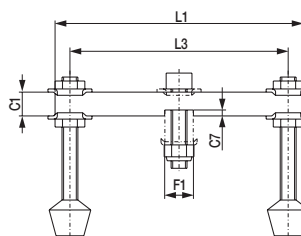

Model no.	For Models with U Arms	C1	C7	F	F1	L1	L3	Adjustable Spindles
207426-Q	207, 225, 227	[0.47] 12	[0.12] 3	[0.31] 35	[0.57] 14,5	[4.92] 125	[4.33] 110	507208-M
210440-Q	210, 235, 237	[0.63] 16	[0.16] 4	[0.43] 11	[0.75] 19	[5.87] 149	[5.12] 130	240208-M

