

HEAVY DUTY MODULAR CONVEYORS

Features, Table of Contents



Features:

CAMCO Heavy Duty Precision Link Conveyors combine excellent accuracy with high load capacity to provide the versatility needed to meet virtually any automated assembly or manufacturing challenge.

Standard link lengths of 6.0", 9.0" and 12"

Over/Under and Carousel configurations

Precision links with roller bearing cam followers for smooth transfer and long life

Provided with heavy-duty legs and a precision machined base designed to hold large loads and maintain system accuracy

Available with adjustable soft machine mounts to accommodate inconsistent on-site flooring

Customize length and height and add optional line shafts or tooling plates to fit your application

Table of Contents

How to Order	IN-HDC-3
Conveyor Options	IN-HDC-4
6.0 Inch Heavy Duty	IN-HDC-5
9.0 Inch Heavy Duty	IN-HDC-7
12.0 Inch Heavy Duty	IN-HDC-9

HEAVY DUTY MODULAR CONVEYORS

How To Order

Required Information

- **Link Size:** 1.5, 2.0, 3.0, 4.5, 6.0, 9.0 or 12.0
- **Type:** Table Top or Heavy Duty
- **Style:** Over/Under or Carousel
- **Length:** Standard per catalog or Custom, expressed as center distance, in inches
- **Height:** Standard per catalog or Custom, in inches

Technical Assistance

All Precision Link Conveyor applications are verified by a IMC sales agent using the IMC Sizing Program.

Your IMC agent is available to make all sizing calculations for you.

Required Information when ordering Drive Package

- **Type:** Standard, Alternate, Heavy-Duty or Special
- **Drive Side:** 1 or 2 (for Over/Under)
- **Index Distance:** In inches
- **Indexer Model:** Specific model number or special

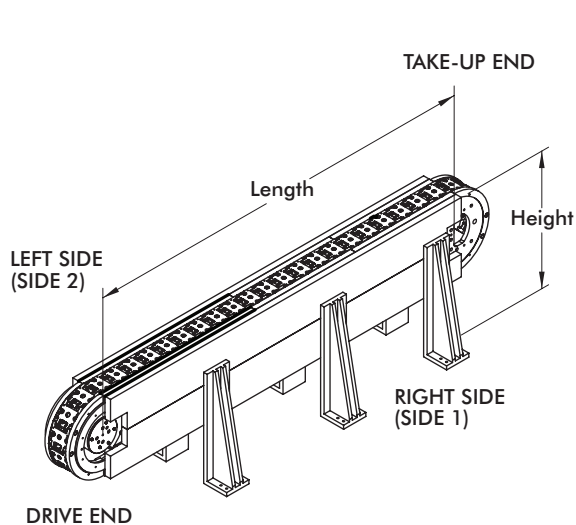

OVER/UNDER

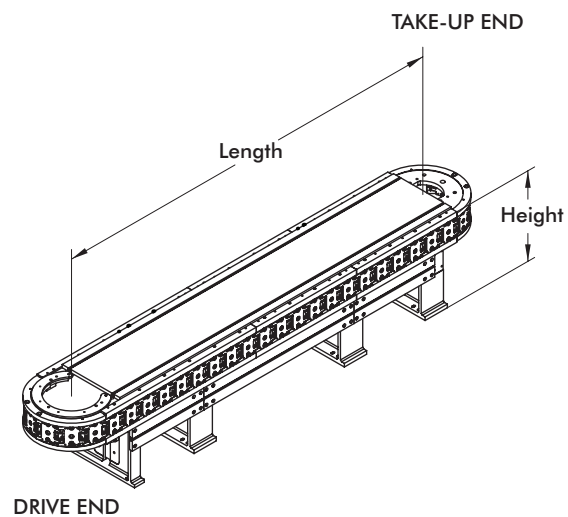

CAROUSEL

HEAVY DUTY MODULAR CONVEYORS

Options

CAMCO offers a wide variety of standard and custom options on all precision link conveyors. Tooling plates and conveyor mainframes can be ordered with custom hole configurations or burnouts. Other standard options include timing chains, timing belts and extended lineshafts. Standard drive package options include CAMCO indexers with AC motors and clutch-brakes, DC motors or servo motors. CAMCO's special Indexer output overload clutches are highly recommended to protect the indexer, link assembly and tooling.

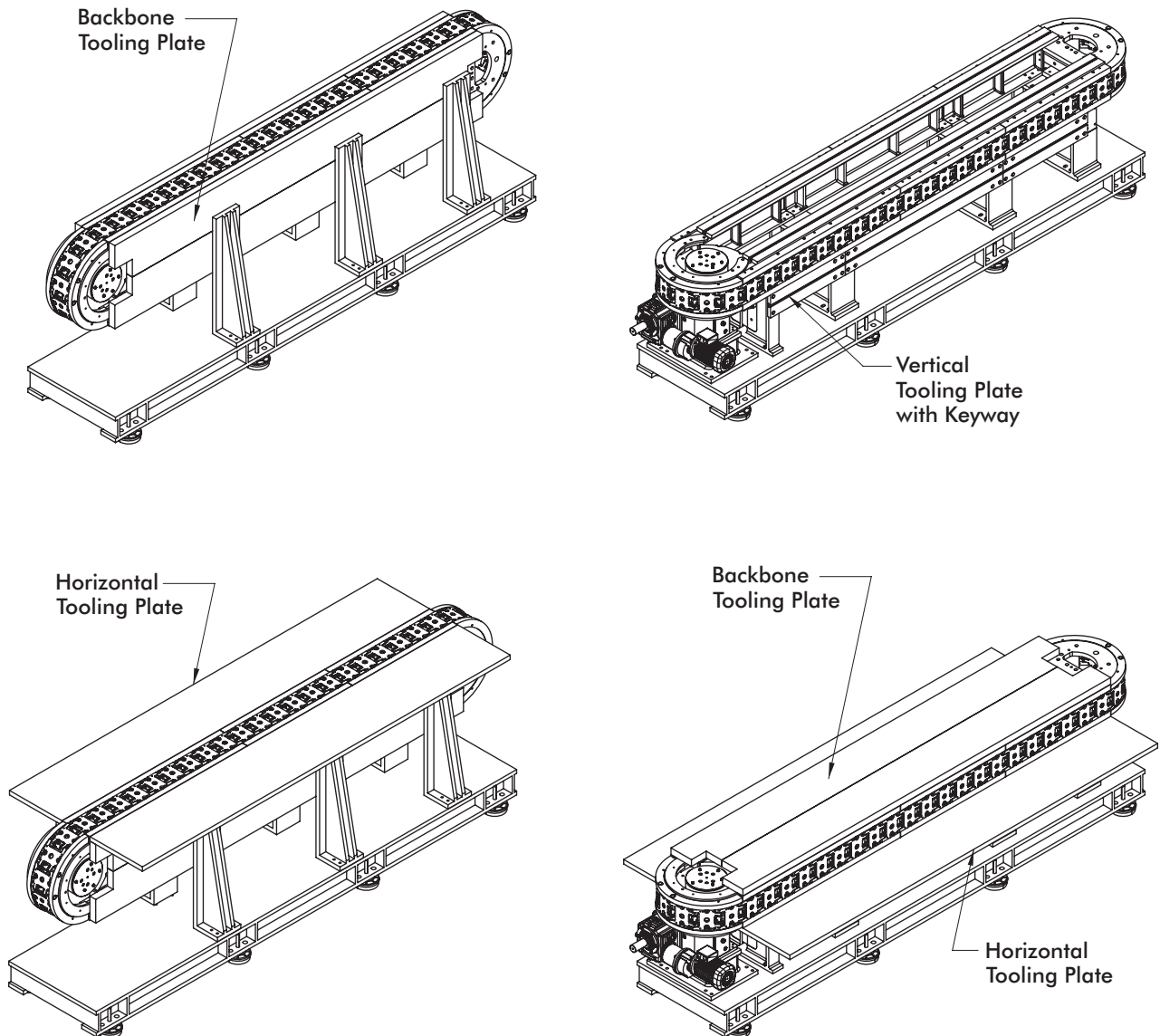

Using Cambot Parts Handlers with Precision Link Conveyors

Cambot linear pick-and-place parts handlers have custom cam motions incorporated into each unit, providing complex synchronize timings for your application. They can be mounted onto the backbone tooling plates of the conveyor. Cambot linear pick-and-place parts handlers can be belt driven off a common line shaft for perfect synchronization. See the Rotary Parts Handler section (page 181) for other possible configurations, such as a rotary pick-and-place device loading parts from a continuous line conveyor to a CAMCO index drive conveyor.

6.0 INCH HEAVY DUTY SERIES

Heavy Duty Modular Conveyors | Configurations

Link

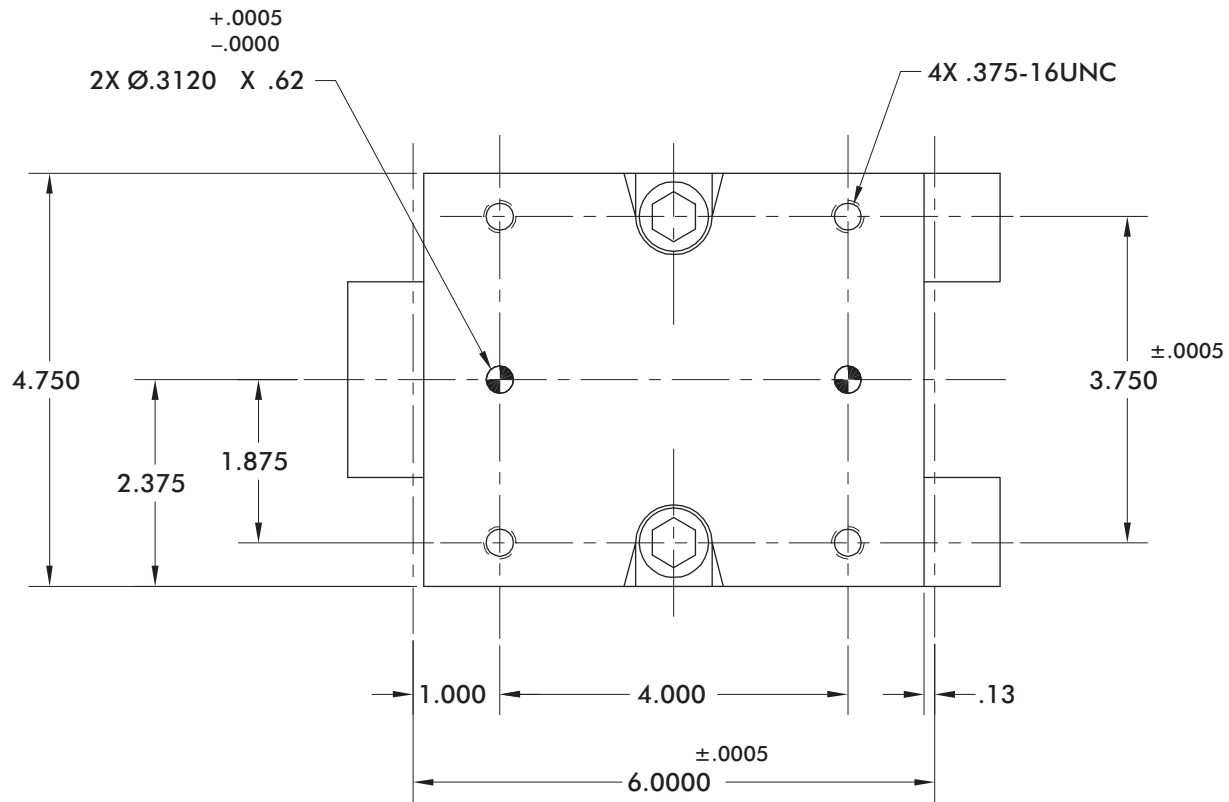

Modular Conveyor (drive package)

Standard Drive Package

- 1301RD Intermittor
- 73500C Reducer
- 5 hp AC Motor
- MDB-1125 Air Clutch-Brake
- Cycle Cam & Limit Switch

Index Distance [in.]	Indexer Stops
6.00	12
12.00	6
18.00	4
24.00	3

6.0 INCH HEAVY DUTY SERIES

Heavy Duty Modular Conveyors | Configurations

Carousel

STANDARD*

A
144.00
216.00
288.00

*Conveyor lengths can be customized for your application. Please consult factory.

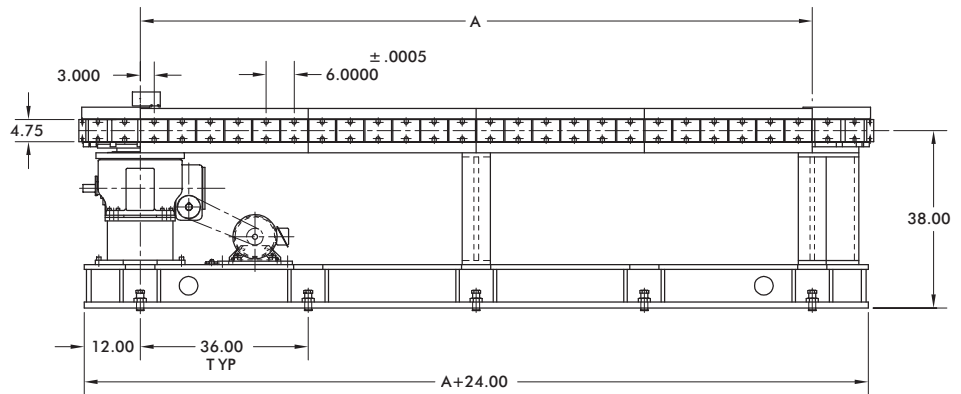
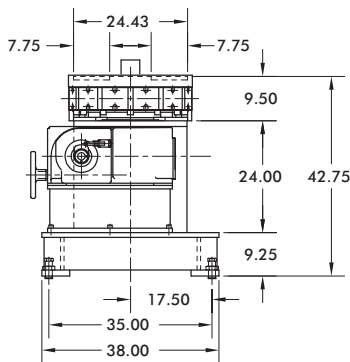
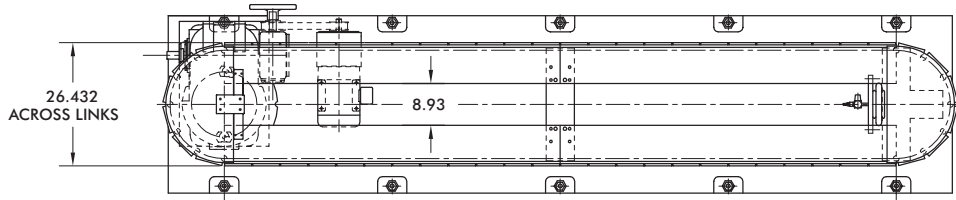

Over/Under

STANDARD*

A
144.00
216.00
288.00

*Conveyor lengths can be customized for your application. Please consult factory.

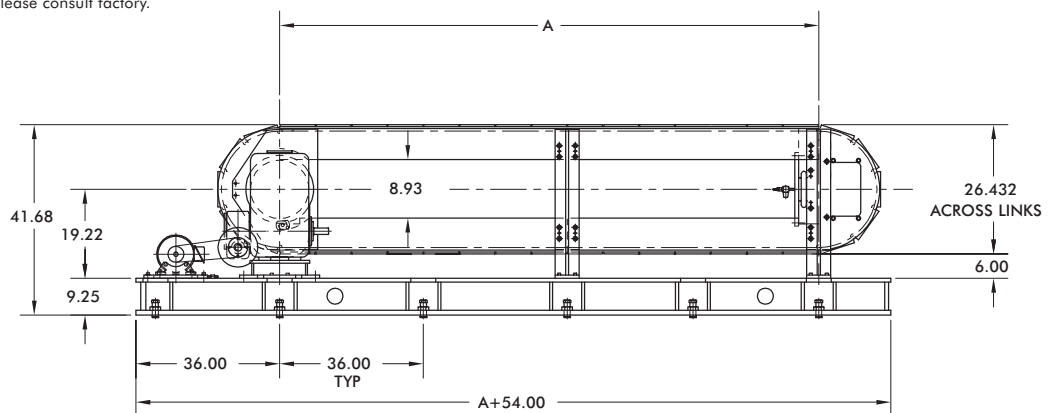
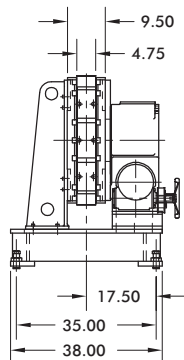
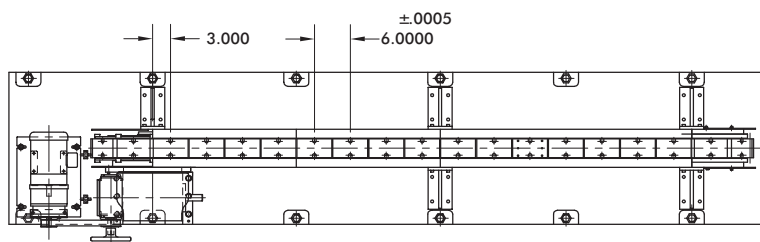

9.0 INCH HEAVY DUTY SERIES

Heavy Duty Modular Conveyors | Configurations

Link

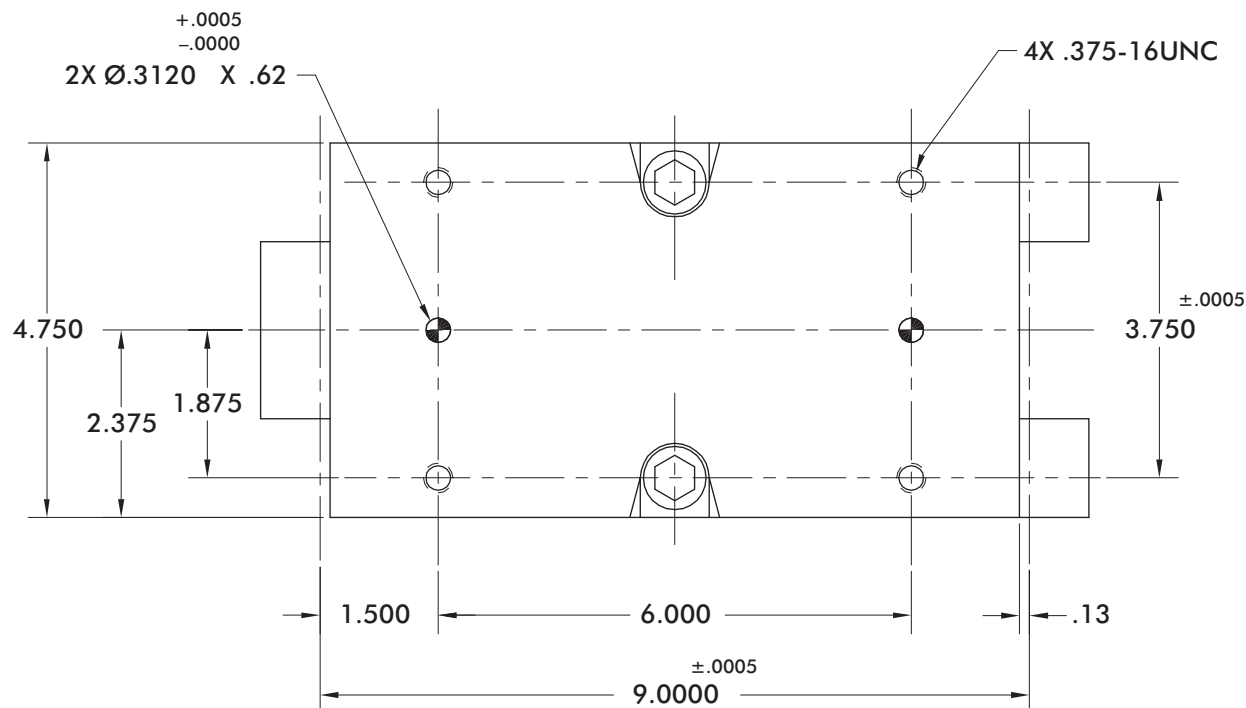

Modular Conveyor (drive package)

Standard Drive Package

- 1301RD Intermittor
- 73500C Reducer
- 5 hp AC Motor
- MDB-1125 Air Clutch-Brake
- Cycle Cam & Limit Switch

Index Distance [in.]	Indexer Stops
9.00	12
18.00	6
27.00	4
36.00	3

9.0 INCH HEAVY DUTY SERIES

Heavy Duty Modular Conveyors | Configurations

Carousel

STANDARD*	
A	
144.00	
216.00	
288.00	

*Conveyor lengths can be customized for your application. Please consult factory.

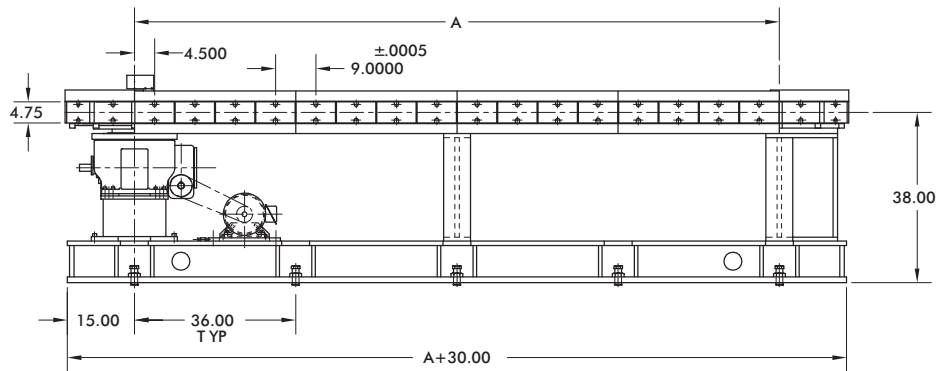
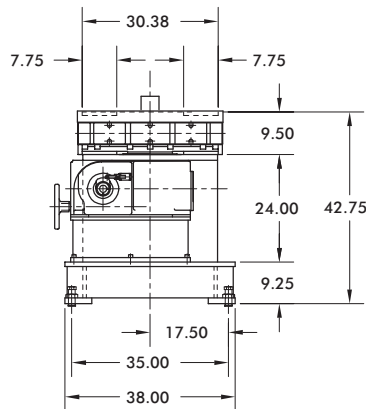
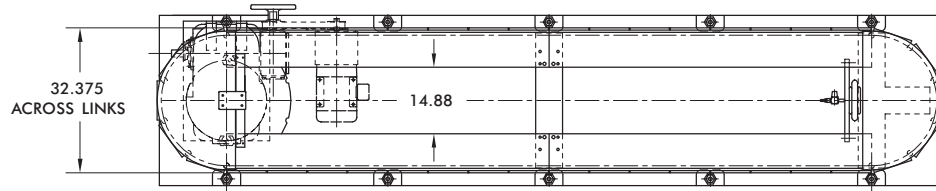

CONVEYOR SHOWN WITH 10-TOOTH SPROCKET

Over/Under

STANDARD*	
A	
144.00	
216.00	
288.00	

*Conveyor lengths can be customized for your application. Please consult factory.

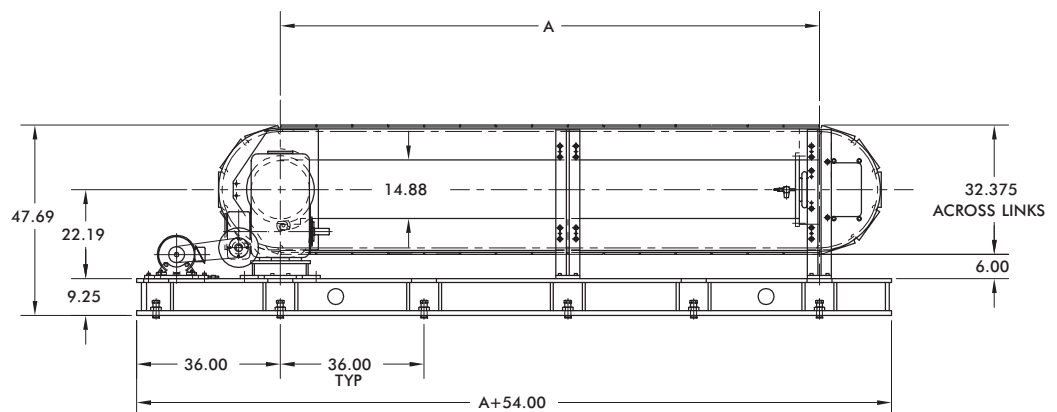
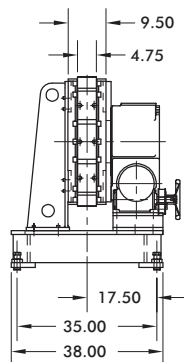
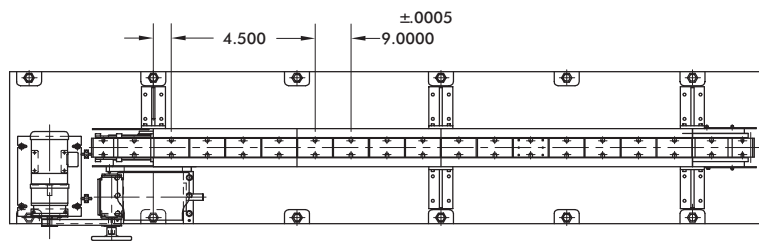

CONVEYOR SHOWN WITH 10-TOOTH SPROCKET

12.0 INCH HEAVY DUTY SERIES

Heavy Duty Modular Conveyors | Configurations

Link

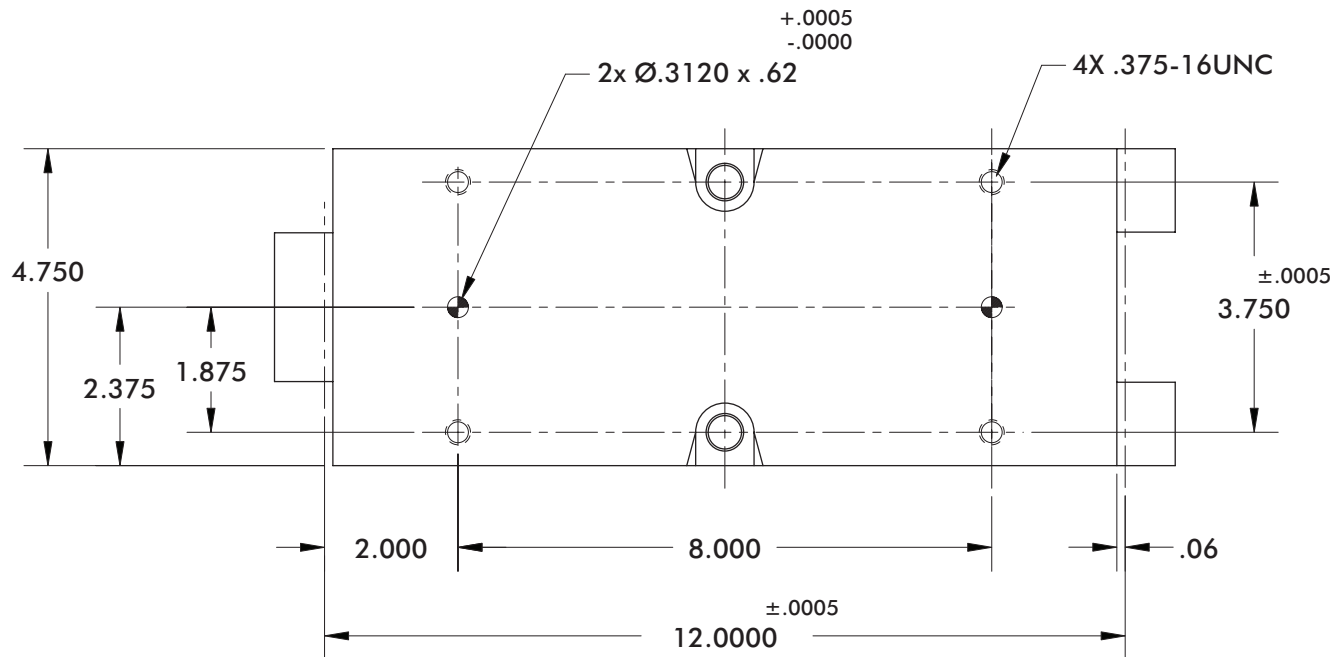

Modular Conveyor (drive package)

Standard Drive Package

- 1301RD Intermittor
- 7500C Reducer
- 5 hp AC Motor
- MDB-1125 Air Clutch-Brake
- Cycle Cam & Limit Switch

Index Distance [in.]	Indexer Stops	Sprocket
12.00	8, 10, 12	8T, 10T, 12T
24.00	4, 5, 6	8T, 10T, 12T
36.00	4	12T
48.00	2, 3	8T, 12T

12.0 INCH HEAVY DUTY SERIES

Heavy Duty Modular Conveyors | Configurations

Carousel

STANDARD*	
A	
144.00	
216.00	
288.00	

*Conveyor lengths can be customized for your application. Please consult factory.

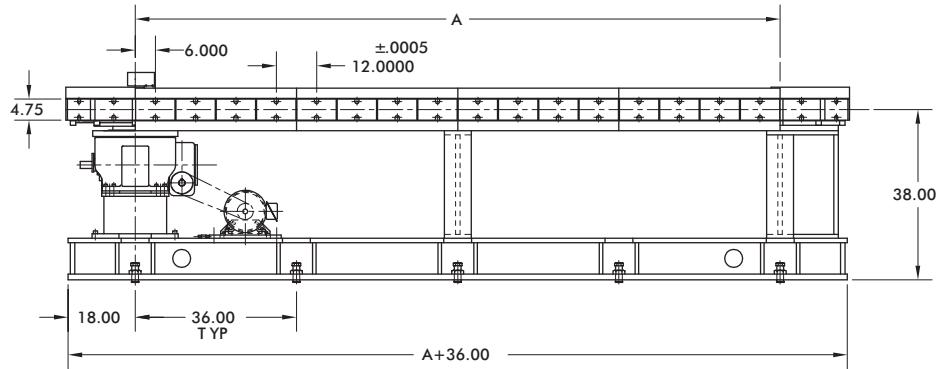
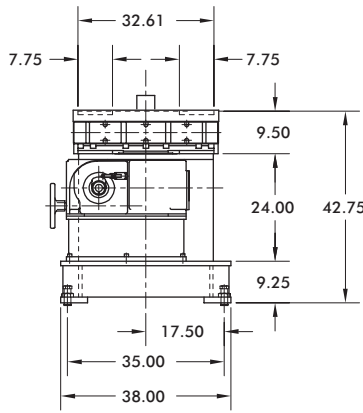
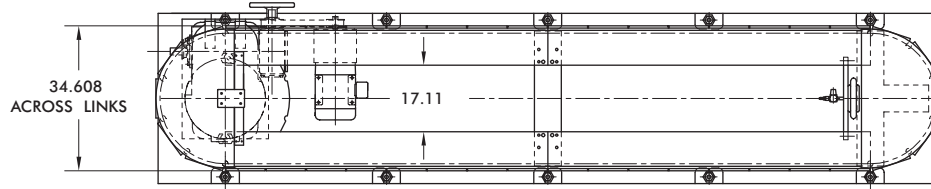

Over/Under

STANDARD*	
A	
144.00	
216.00	
288.00	

*Conveyor lengths can be customized for your application. Please consult factory.

