

PARALLEL SHAFT/FLANGE DRIVES

Features/Table of Contents

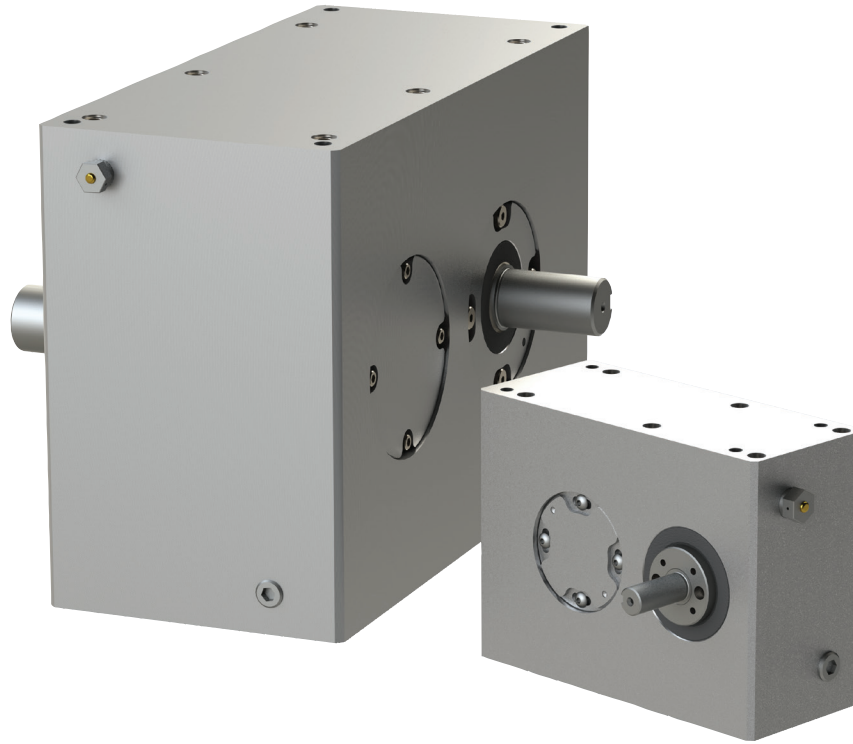

Features:

Camco Parallel Index Drives are ideal for high-speed applications or for actuation-type applications such as driving a linkage or a conveyor.

Hardened and ground conjugate cams

Yoke-mounted, preloaded cam followers are non-reversing for high capacity and speed capability

Whole or fractional stops, oscillating and complex custom motions are available

Long transfer distances achieved with simple linkages

Preloaded, tapered roller bearings for rigidity and backlash-free operation

Table of Contents

How to Order	IN-PAR-3
250P	IN-PAR-5
387P	IN-PAR-7
512P	IN-PAR-9
662P	IN-PAR-11

P SERIES

Parallel Shaft/Flange Drives | How To Order

Indexer Ordering Procedure

1. Input Assembly: Right, Left or Double (DE)
2. Output Assembly: Right, Left or Double (DE).
 - Flanged output is primary output. For Double Output, specify whether flanged output is on right or left side.

NOTE: Input may rotate in either direction to achieve desired direction of output rotation.

3. Mounting Position: 1-6

Reducer Ordering Procedure

1. Model
2. Ratio: 5:1, 10:1, 15:1, 20:1, 25:1, 30:1, 40:1, 50:1, 60:1
3. Motor Adapter
4. Reducer Input Shaft Extension: Single Input (SE) or Double Input (DE)
5. Mounting (see diagram below)

Position of Shafts (Top View)

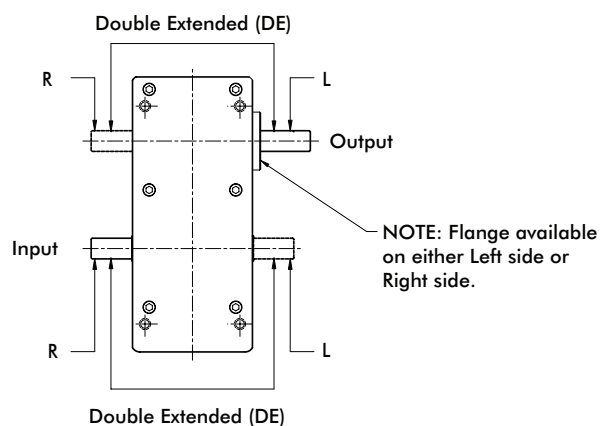

Input/Output Shaft Rotation

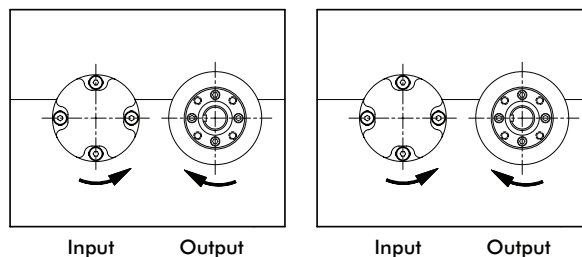

Parallel Shaft/Flange Drives | Indexer Mounting Position

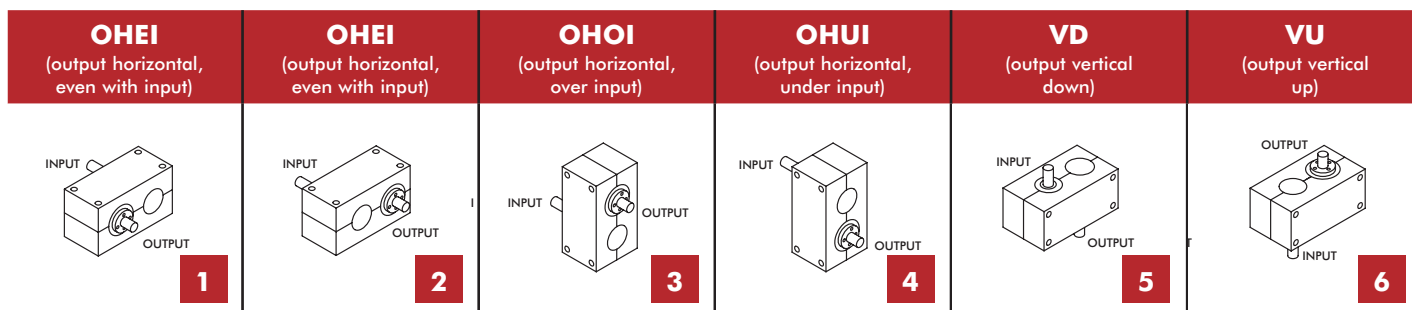

Gear Reducer Mounting Positions (Figure 4)

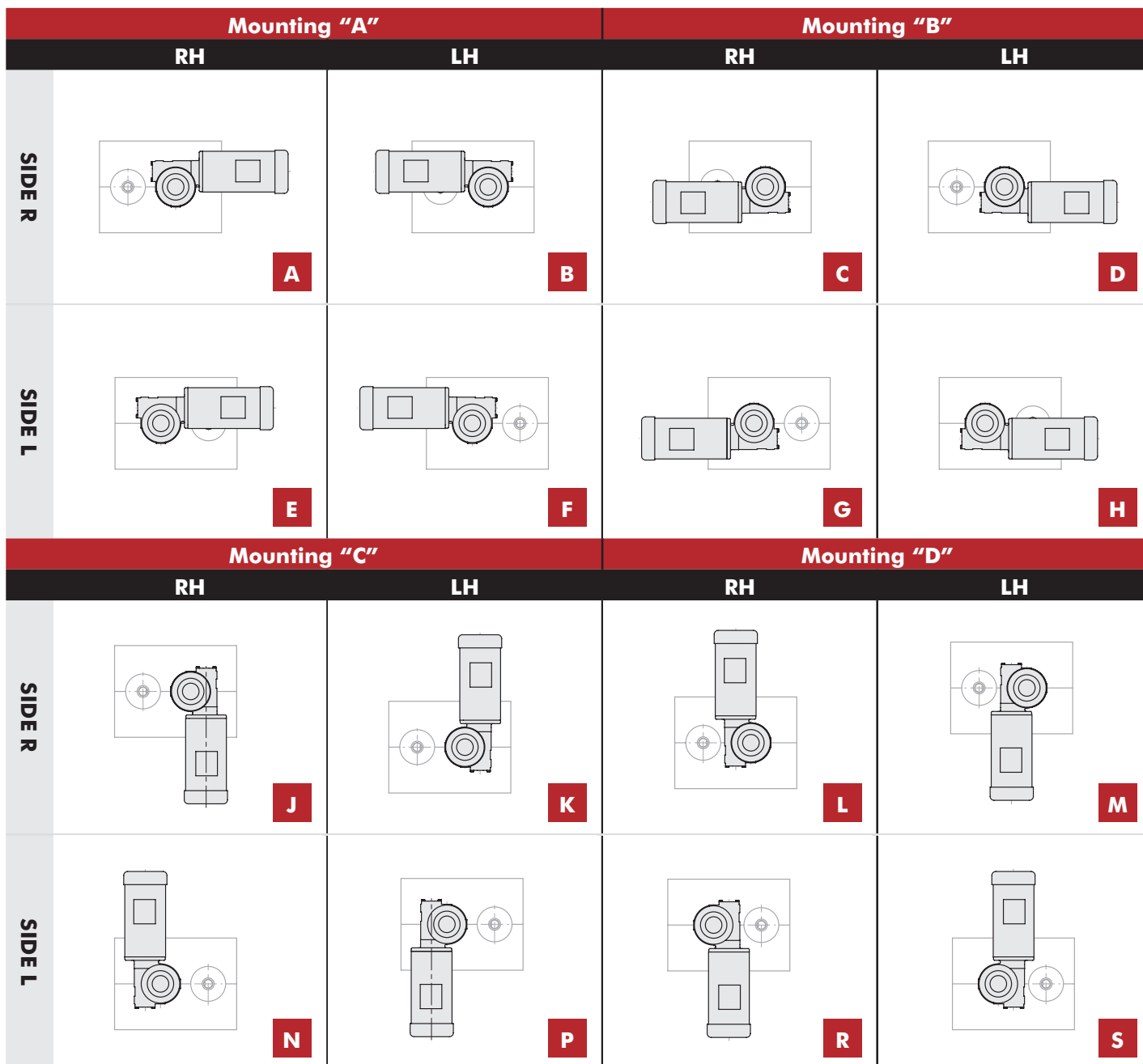

250P SERIES

Parallel Shaft/Flange Drives | Dimensions

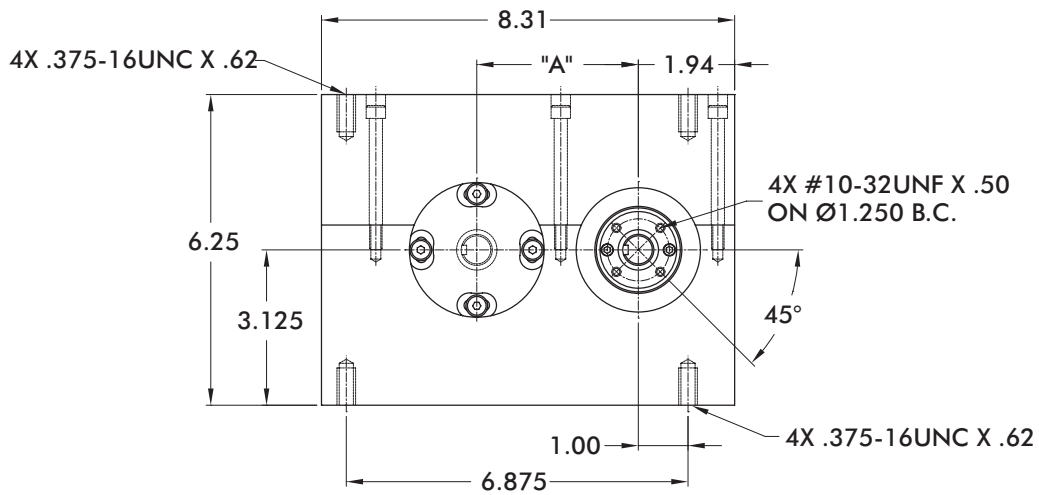
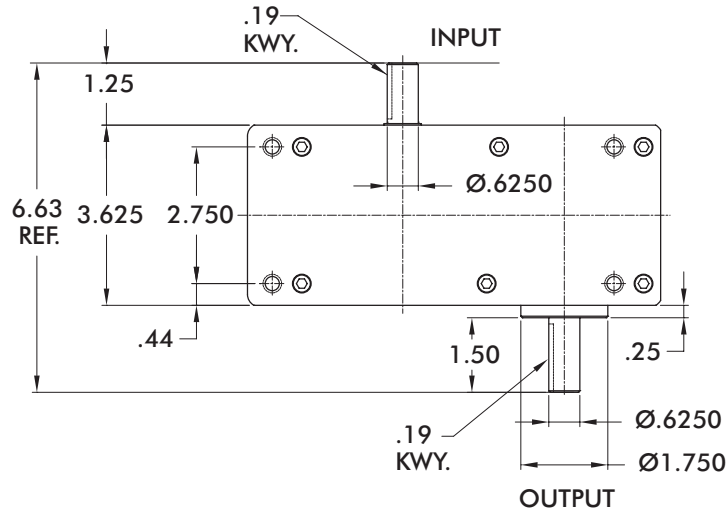

250P SERIES

Parallel Shaft/Flange Drives | Features, Optional Accessories, Technical Information

250P Indexer Capacities						
Stops	Index Period	Motion	B ₁₀ Capacity at 50 RPM (in-lb)	Internal Inertia (lb-in ²)	Model	"A" Center
1	300	msc.50	444	3	250P1H20-300	3.25
1.5	270	msc.33	481	2	250P1.5H20-270	3.25
2	270	ms	433	3	250P2H20-270	3.25
	180	msc.33	546	3	250P2H20-180	3.25
3	270	ms	582	2	250P3H20-270	2.75
	120	ms	653	2	250P3H20-120	3.25
4	270	ms	571	3	250P4H20-270	2.75
	90	msc.25	782	3	250P4H20-90	3.25
6	270	ms	888	2	250P6H20-270 II	2.75
	180	msc.33	2078	3	250P6H24-180 II	2.75
8	270	ms	843	3	250P8H20-270 II	2.75
	120	ms	993	3	250P8H20-120 II	3.25

Other Motions (stops and index periods) available. Contact your DE-STA-CO sales representative for more information.

Features

- Single Input Shaft and Single Output Shaft
- Output horizontal even with input Mounting
- R180 Reducer (ratios from 15:1 to 60:1)
 - Double Extended Worm (input) Shaft
 - Worm Shaft Handwheel
- 1/3 or 1 hp AC Drive Package with Inverter Duty Motor and Inverter Drive (up to 60 cpm)
- Single Cycle Cam and Limit Switch

Output Load Capacity (loads carried during index):

Radial	316 lbs
Thrust/Axial	314 lbs
Moment	395 in-lb

Accuracy ±77 arcsec / ±.0011" at 3" Radius

Repeatability ±19 arcsec / ±.0003" at 3" Radius

Optional Accessories

- 1/3 hp DC motor
- Varipak DC Motor Control (up to 30 cpm)
- R225 Reducer (ratios from 10:1 to 60:1)
 - 1 hp AC or DC drive package
 - 56C Motor Adapter and Coupling
- Output Overload Clutch Models: .39F, .39FC, .39S and .39C, .39C-SD, .39FC-SD, .39S-SD
 - Available Settings (in-lb): 160, 210, 270, 320, 390
- Dual Cycle Cam and Limit Switch
- Oscillating motion
- Double Input Shaft
- Double Output Shaft
- Output and Input Vertical Mounting

387P SERIES

Parallel Shaft/Flange Drives | Dimensions

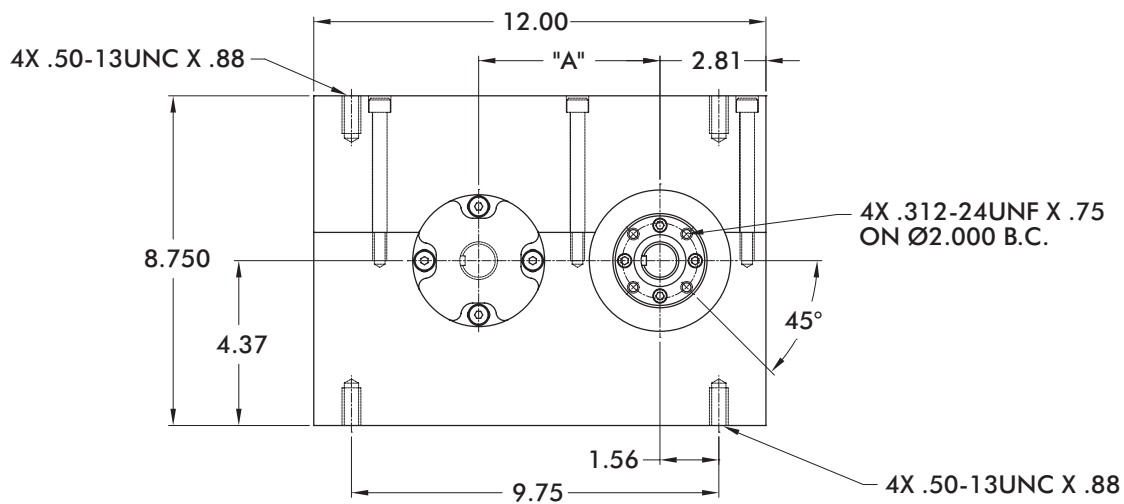
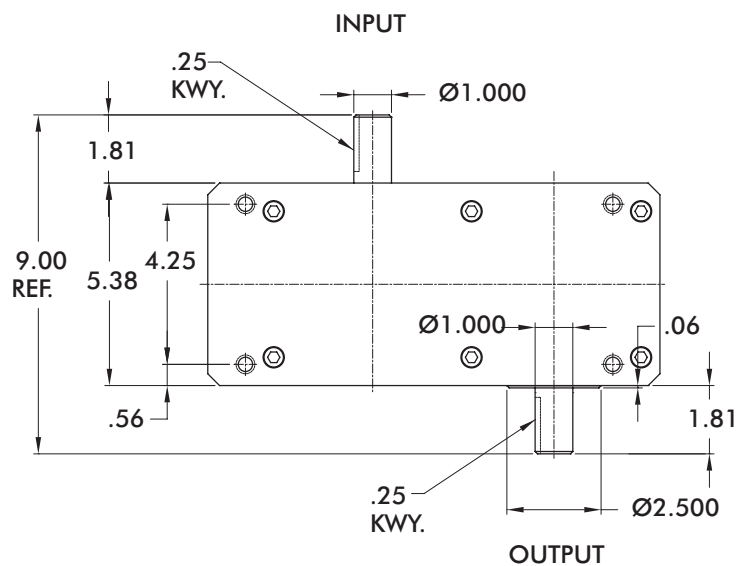

387P SERIES

Parallel Shaft/Flange Drives | Features, Optional Accessories, Technical Information

387P Indexer Capacities						
Stops	Index Period	Motion	B ₁₀ Capacity at 50 RPM (in-lb)	Internal Inertia (lb-in ²)	Model	"A" Center
1	300	msc.66	1385	14	387P1H28-300	4.812
1.33	315	msc.10	1062	13	387P1.33H28-315	4.812
1.5	300	ms	1099	13	387P1.5H28-300	4.812
2	270	msc.33	1788	14	387P2H32-270	4.812
	180	msc.33	2095	14	387P2H32-180	4.812
2.67	270	msc.33	2171	14	387P2.67H28-270 II	4.812
3	270	ms	1601	13	387P3H28-270	4
	120	msc.33	2067	14	387P3H28-120	4.812
4	270	ms	1605	14	387P4H28-270	4
	90	msc.33	2214	14	387P4H28-90	4.812
6	270	ms	2445	13	387P6H28-270 II	4
	180	ms	2463	13	387P6H28-180 II	4.812
8	270	ms	2378	14	387P8H28-270 II	4

Other Motions (stops and index periods) available. Contact your DE-STA-CO sales representative for more information.

Features

- Single Input Shaft and Single Output Shaft
- Output horizontal even with input Mounting
- R225 Reducer (ratios from 10:1 to 60:1)
 - 56C Motor Adapter and Coupling
- 1 hp AC Drive Package with Inverter Duty Motor and Inverter Drive (up to 60 cpm)
- Single Cycle Cam and Limit Switch

Output Load Capacity (loads carried during index):

Radial	895 lbs
Thrust/Axial	577 lbs
Moment	1,620 in-lb

Accuracy ±50 arcsec / ±.0007" at 3" Radius

Repeatability ±12 arcsec / ±.0002" at 3" Radius

Optional Accessories

- 1 hp DC motor
- Varipak DC Motor Control (up to 30 cpm)
- R260 Reducer (ratios from 5:1 to 60:1)
 - 1 hp AC or DC drive package
 - 56C Motor Adapter and Coupling
- Output Overload Clutch Models: 2.3F, 2.3FC, 2.3S and 2.3C, 2.3C-SD, 2.3FC-SD, 2.3S-SD
 - Available Settings (in-lb): 400, 600, 700, 850, 1000, 1300, 1800, 2000, 2300
- Dual Cycle Cam and Limit Switch
- Oscillating motion
- Double Input Shaft
- Double Output Shaft
- Output and Input Vertical Mounting

512P SERIES

Parallel Shaft/Flange Drives | Dimensions

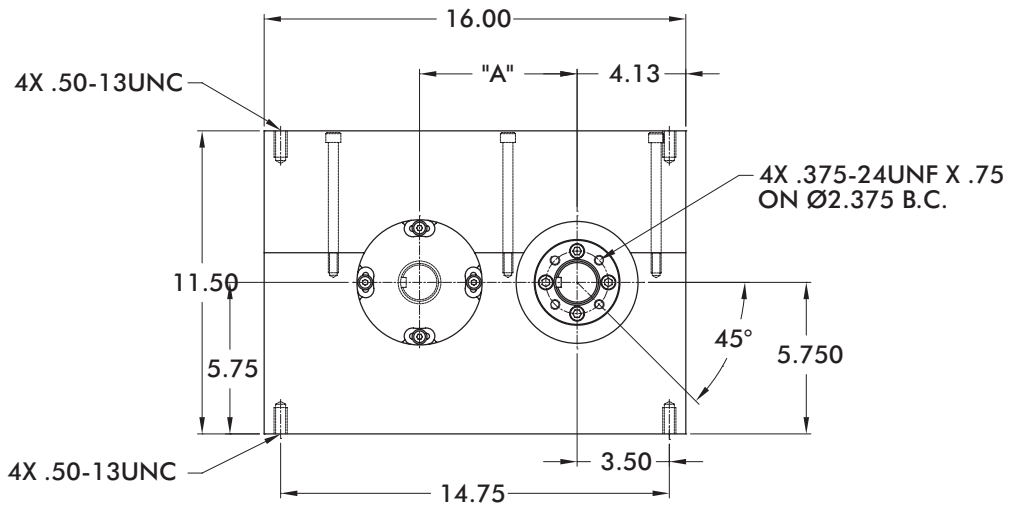
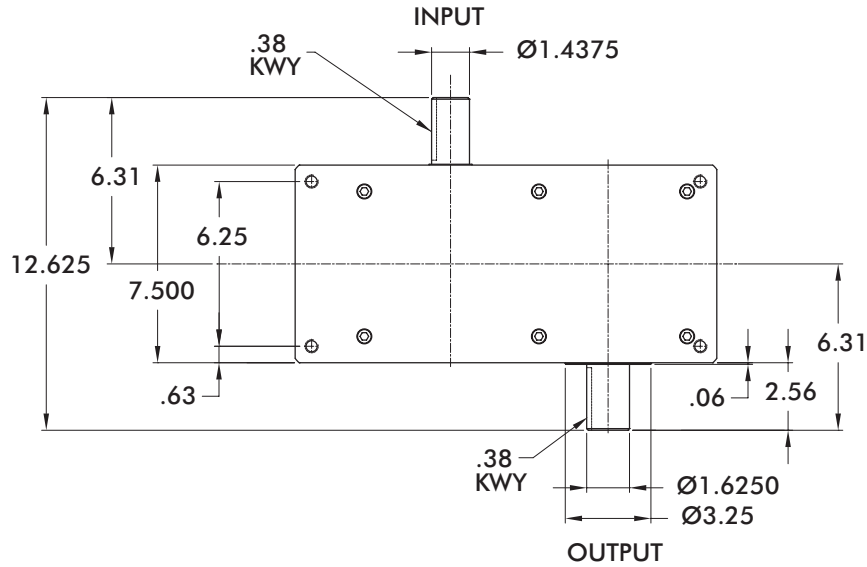

512P SERIES

Parallel Shaft/Flange Drives | Features, Optional Accessories, Technical Information

512P Indexer Capacities						
Stops	Index Period	Motion	B ₁₀ Capacity at 50 RPM (in-lb)	Internal Inertia (lb-in ²)	Model	"A" Center
1	330	msc.75	6441	63	512P1H48-330	5.979
1.33	330	msc.33	4928	61	512P1.33H48-330	5.979
1.5	330	ms	4860	63	512P1.5H48-330	5.979
	270	msc.33	4373	61	512P2H40-270	5.979
2	180	msc.50	5416	61	512P2H40-180	5.979
	120	msc.50	4131	61	512P2H40-120	5.979
3	300	msc.33	7116	61	512P2.67H40-300 II	5.979
	180	ms	5462	56	512P3H40-180	5.979
4	270	ms	5619	61	512P4H40-270	4.858
	120	ms	6252	61	512P4H40-120	5.979
6	270	ms	8315	56	512P6H40-270 II	4.858
	180	ms	8261	56	512P6H40-180 II	5.979
8	270	ms	8387	61	512P8H40-270 II	4.858
	180	ms	7894	61	512P8H40-180 II	5.979

Other Motions (stops and index periods) available. Contact your DE-STA-CO sales representative for more information.

Features

- Single Input Shaft and Single Output Shaft
- Output horizontal even with input Mounting
- R225 Reducer (ratios from 10:1 to 60:1)
 - 56C Motor Adapter and Coupling
- 1 hp AC Drive Package with Inverter Duty Motor and Inverter Drive (up to 60 cpm)
- Single Cycle Cam and Limit Switch

Output Load Capacity (loads carried during index):

Radial	2,715 lbs
Thrust/Axial	1,374 lbs
Moment	6,951 in-lb

Accuracy ±37 arcsec / ±.0005" at 3" Radius

Repeatability ±9 arcsec / ±.0001" at 3" Radius

Optional Accessories

- 1 hp DC motor
- Varipak DC Motor Control (up to 30 cpm)
- R260 Reducer (ratios from 5:1 to 60:1)
 - 1 hp AC or DC drive package
 - 56C Motor Adapter and Coupling
- Output Overload Clutch Models: 6.0F, 6.0FC, 6.0S and 6.0C, 6.0C-SD, 6.0FC-SD, 6.0S-SD
 - Available Settings (in-lb): 670, 825, 1100, 1400, 1700, 2000, 2300, 2500, 3000, 3800, 4000, 5000, 6000
- Dual Cycle Cam and Limit Switch
- Oscillating motion
- Double Input Shaft
- Double Output Shaft
- Output and Input Vertical Mounting

662P SERIES

Parallel Shaft/Flange Drives | Dimensions

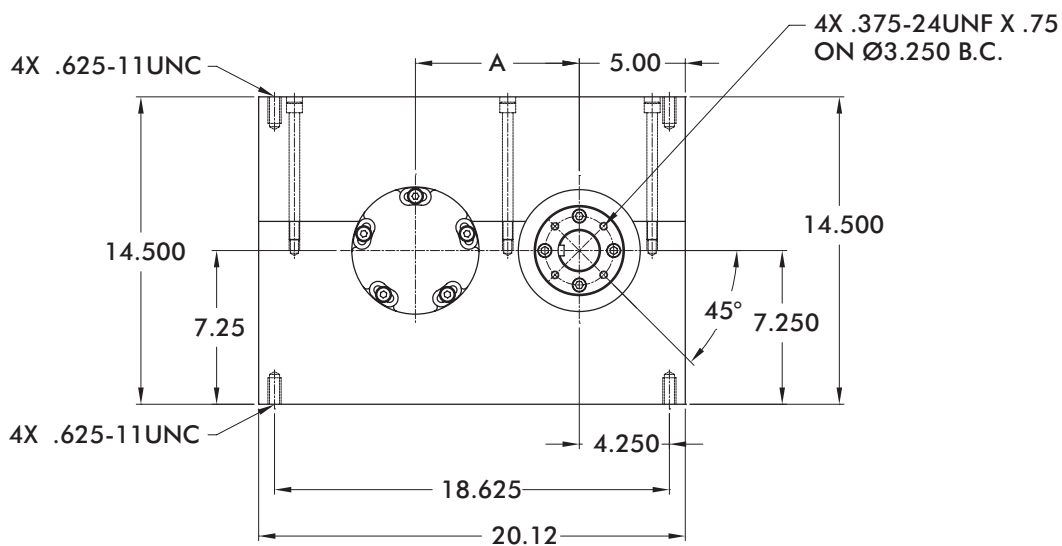
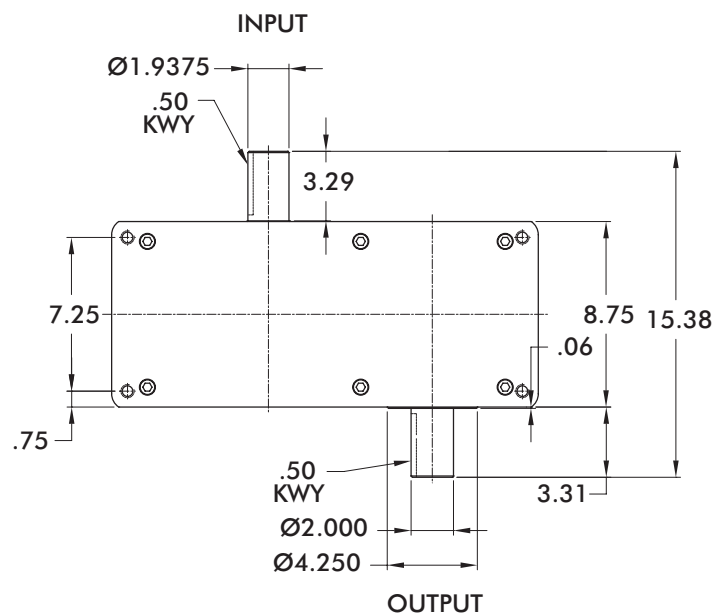

662P SERIES

Parallel Shaft/Flange Drives | Features, Optional Accessories, Technical Information

662P Indexer Capacities						
Stops	Index Period	Motion	B ₁₀ Capacity at 50 RPM (in-lb)	Internal Inertia (lb-in ²)	Model	"A" Center
1	330	msc.50	5824	138	662P1H48-330	7.729
1.33	330	msc.20	10368	332	662P1.33H64-330	7.729
1.5	270	msc.33	12617	306	662P1.5H64-270	7.729
2	270	msc.33	6811	181	662P2H48-270	7.729
	180	msc.50	11760	204	662P2H56-180	7.729
3	270	ms	8446	166	662P3H48-270	6.628
	180	ms	8506	166	662P3H48-180	7.729
4	270	ms	8752	181	662P4H48-270	6.628
	120	ms	9738	181	662P4H48-120	7.729
6	270	ms	12946	166	662P6H48-270 II	6.628
	180	ms	12863	166	662P6H48-180 II	7.729
8	270	ms	13060	181	662P8H48-270 II	6.628
	120	msc.33	15780	181	662P8H48-120	7.729

Other Motions (stops and index periods) available. Contact your DE-STA-CO sales representative for more information.

Features

- Single Input Shaft and Single Output Shaft
- Output horizontal even with input Mounting
- R225 Reducer (ratios from 10:1 to 60:1)
 - 56C Motor Adapter and Coupling
- 1 hp AC Drive Package with Inverter Duty Motor and Inverter Drive (up to 60 cpm)
- Single Cycle Cam and Limit Switch

Output Load Capacity (loads carried during index):

Radial	3,915 lbs
Thrust/Axial	2,042 lbs
Moment	12,959 in-lb

Accuracy ±36 arcsec / ±.001" at 6" Radius

Repeatability ±9 arcsec / ±.0003" at 6" Radius

Optional Accessories

- 7350C or 7400C Reducer (ratios from 5:1 to 60:1) with Motor Adapter and Coupling
- 1 hp DC Motor
- Output Overload Clutch Models: 11F, 11FC, 11FC-SD
 - Available Settings (in-lb): 2300, 4000, 6000, 8500, 11000
- Dual Cycle Cam and Limit Switch
- Electric Clutch-Brake
- Air Clutch-Brake
- Oscillating motion
- Double Input Shaft
- Double Output Shaft
- Output and Input Vertical Mounting