

Machine and fixture components







Technical information for sliding clamps K1070 and K1072

Note:

The items are used as movable clamping elements on applications such as measuring scales.

Turning the knob to “ON”, operates the clamping mechanism. In the “OFF” position the element is movable. The switch must be in the “OFF” position during assembly.

If the sliding clamp is mounted directly on a base plate and the plate with slotted hole or square bar is secured, the sliding clamp and the base plate can be moved.

If the sliding clamp is mounted directly on a base plate and the base plate is secured, the plate with slotted hole or square bar can be moved.

Operating mode 1:

Sliding clamp with base element moveable – plates with slotted hole or square fixed

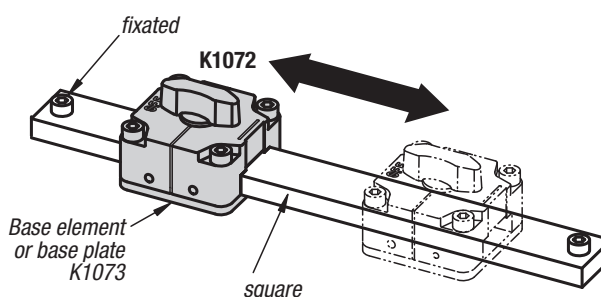
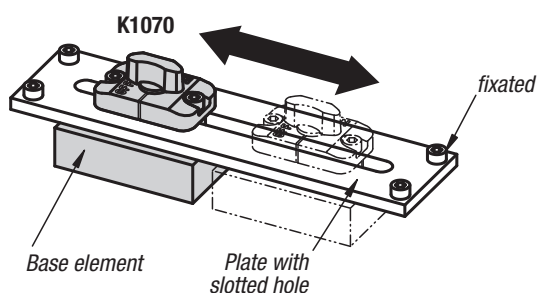

Operating mode 2:

Plates with slotted hole or square bar moveable - Sliding clamp with base element fixated

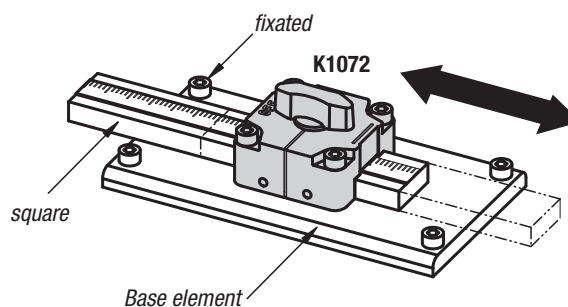
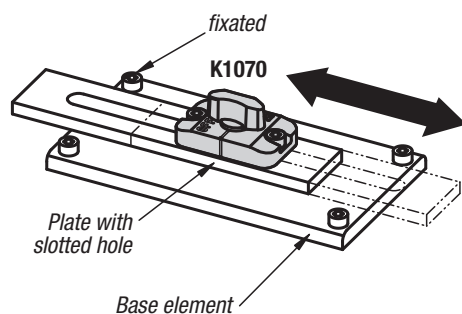

Application example K1070

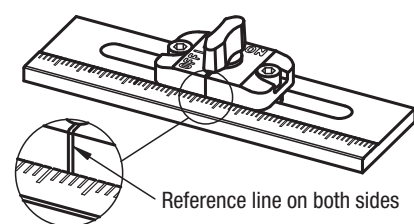

Application example K1072

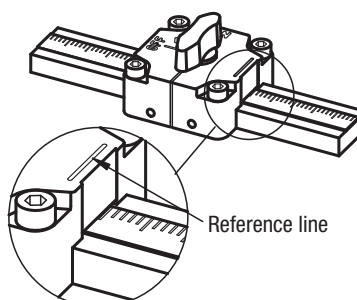

K1070

Sliding clamps

for slotted holes



Material:
Housing die-cast zinc.
Knob thermoplastic PA (polyamide).

Pins and wedge stainless steel.
Thrust pad POM.

Version:
Housing chromed.
Knob black or orange, glass-bead reinforced.

Sample order:
K1070.32

Note:
Sliding clamps for slotted holes are inserted into an upper plate with an 10-mm-wide slotted hole and then fixed to the base plate. The knob must be turned to the "OFF" position while the component is being installed. The sliding clamps are used for precision plates with a thickness of 3 mm or 6 mm. For other thicknesses shim plates K1071 must be used. By turning the knob, the pins mounted in the bottom section of sliding clamp are drawn together by the springs and forced downwards. The two pins press against the surface and clamp the sliding clamp. Two spring plungers lift the sliding clamp in the "ON" position allowing easier movement.

Accessories:
Base plates K1071.

Functional principle:
The sliding clamps have 2 different operating principles.

Operating principle 1:
The sliding clamp is movable. The sliding clamp is bolted onto a loose plate or block placed under a fixated slotted plate. The sliding clamp together with the plate or block can be slid up and down the fixated slotted plate.

Operating principle 2:
The sliding clamp is fixated. The sliding clamp is bolted onto a fixated plate or block placed under a loose slotted plate. The sliding clamp cannot move but the slotted plate can be slid up and down over the fixated plate or block.

Drawing reference:
1) Spring plungers (2x)
2) Chamfer ~0,3

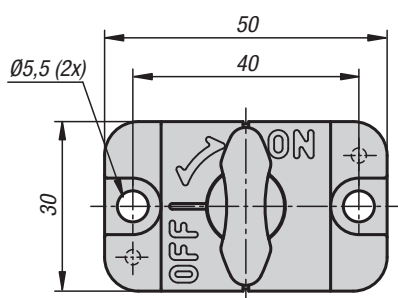
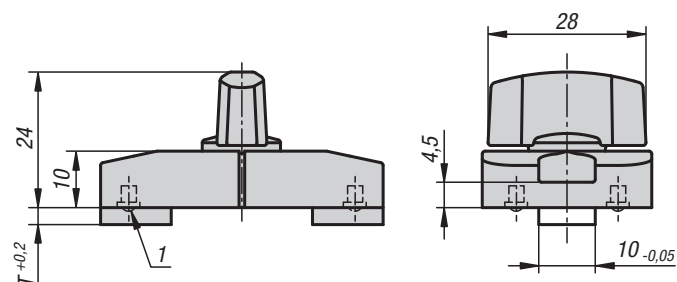

Installation dimensions counterpart

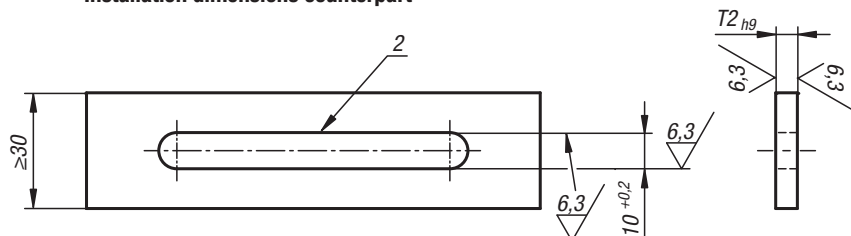

Displacement on static load from one direction

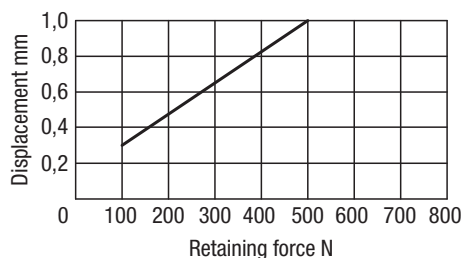

The forces apply to steel or stainless steel plates

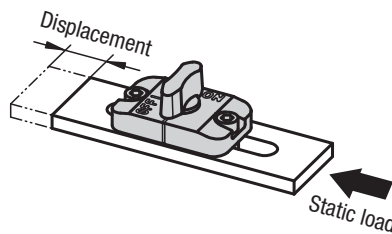

KIPP Sliding clamps for slotted holes

Order No. black	Order No. Orange	T	T2	Holding force N	Temp. resistance up to
K1070.31	K1070.32	3	3	500	90 °C
K1070.61	K1070.62	6	6	500	90 °C

K1071



Shim plates

for sliding clamps for slotted hole

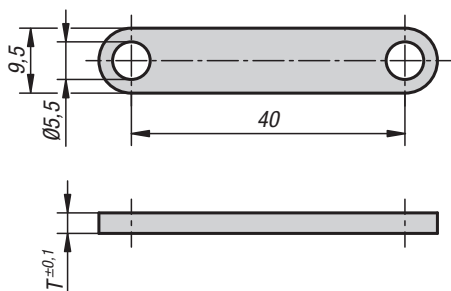
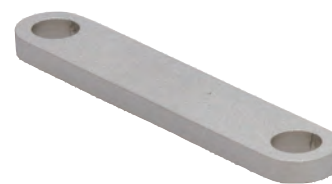

Material:
Stainless steel

Version:
Bright.

Sample order:
K1071.2

Note:
Shim plates are required for sliding clamps for slotted holes with a plate thickness more than 3 mm or 6 mm.

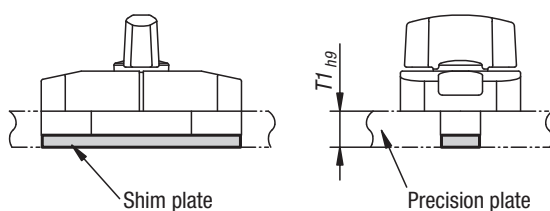

Sliding clamp for slotted holes	Suitable shim plate	Precision plate T1 (mm)
K1070.31 K1070.32	-	3 _{-0,25}
	K1071.2	5 _{-0,3}
K1070.61 K1070.62	-	6 _{-0,3}
	K1071.2	8 _{-0,36}
	K1071.3	9 _{-0,36}

KIPP Shim plates for sliding clamps for slotted hole

Order No.	T
K1071.2	2
K1071.3	3



K1072

Sliding clamps

for square bars

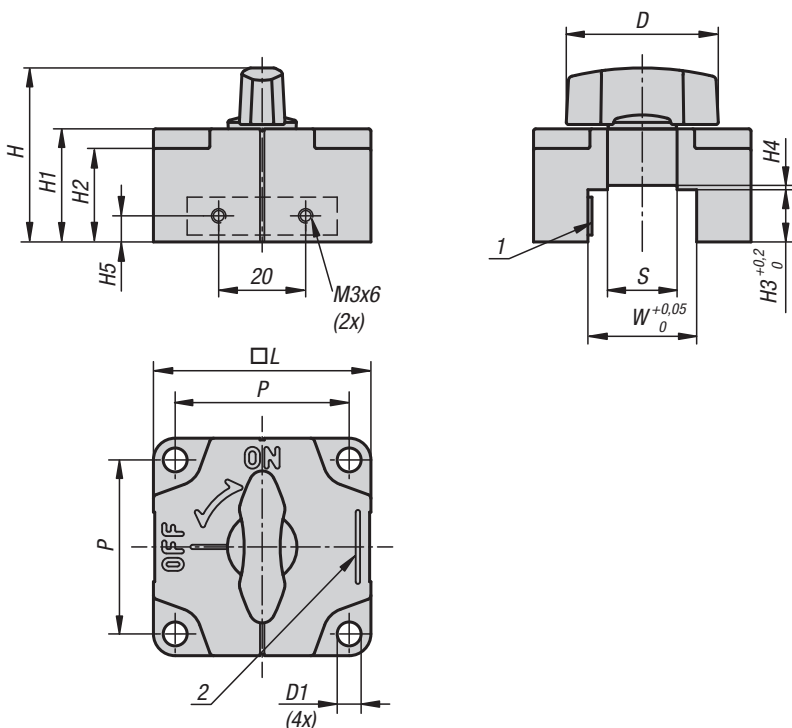

Installation dimensions counterpart square bar

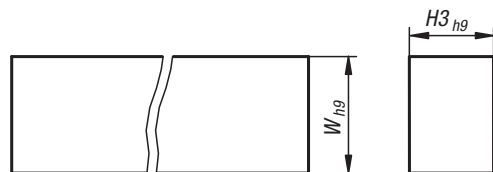

Displacement on static load from one direction

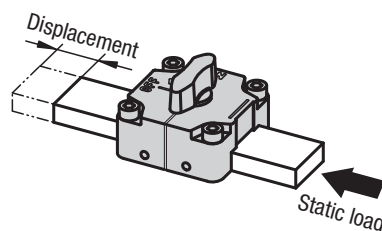
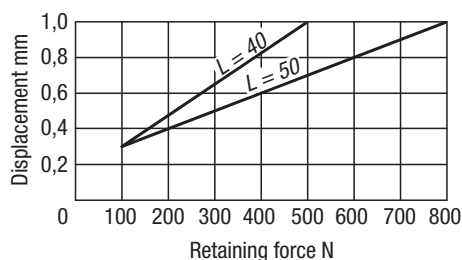

The forces apply to steel or stainless steel square material

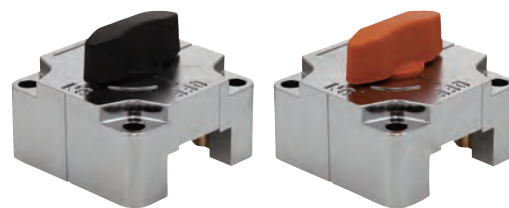

Material:
 Housing die-cast zinc.
 Knob thermoplastic PA (polyamide).
 Pins and wedge stainless steel.
 Leaf spring phosphated bronze.

Version:
 Housing chromed.
 Knob black or orange, glass-bead reinforced.
 Pins and wedge bright.

Sample order:
 K1072.16162

Note:
 By turning the knob, the pins mounted in the bottom section of the sliding clamp are drawn together by the springs and forced downwards. The two pins press against the surface and fixate the sliding clamp.

Accessories:
 Base plates K1073.
 Scales stainless steel K0759.

Functional principle:
 The sliding clamps have 2 different operating principles.

Operating principle 1:
 The sliding clamp is movable.
 The sliding clamp is bolted onto a base plate (K1073), loose plate or block placed under a fixated rectangular bar. The sliding clamp together with the plate or block can be slid up and down the fixated bar.

Operating principle 2:
 The sliding clamp is fixated.
 The sliding clamp is bolted onto a fixated plate or block placed under a loose rectangular bar. The sliding clamp cannot move but the bar can be slid up and down over the fixated plate or block.

Drawing reference:
 1) Leaf spring
 2) Reading line for scales

KIPP Sliding clamp for square bars

Order No. black	Order No. Orange	L	D	D1	H	H1	H2	H3	H4	H5	P	W	S	Holding force N	Temp. resistance up to
K1072.12121	K1072.12122	40	28	4,5	36	22	18,5	12	-	6	32	12	-	500	90 °C
K1072.16161	K1072.16162	40	28	4,5	40	26	22,5	16	-	8	32	16	-	500	90 °C
K1072.2591	K1072.2592	50	35	5,5	37	23	18,5	9	1	4,5	40	25	16	800	90 °C
K1072.25121	K1072.25122	50	35	5,5	40	26	21,5	12	1	6	40	25	16	800	90 °C
K1072.32121	K1072.32122	50	35	5,5	40	26	21,5	12	1	6	40	32	16	800	90 °C
K1072.32161	K1072.32162	50	35	5,5	44	30	25,5	16	1	8	40	32	16	800	90 °C

K1073

Base plates

for sliding clamp for square bars

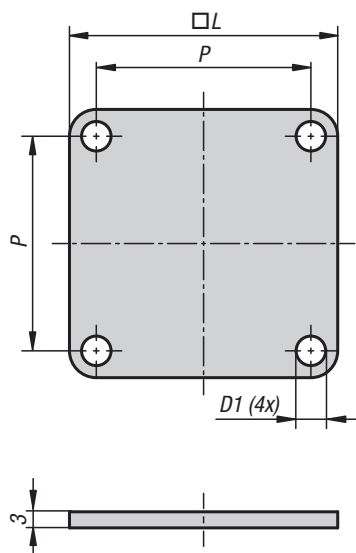
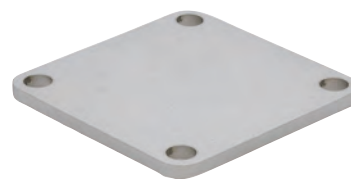
**Material:**

Stainless steel

Version:

Bright.

Sample order:

K1073.40

Note:

Base plates raise the sliding clamp by 3 mm.

It is used to mount the sliding clamp to a fixated square bar.



KIPP Base plate for sliding clamps for square bars

Order No.	L	D1	P
K1073.40	40	4,5	32
K1073.50	50	5,5	40

Studs

DIN 6379

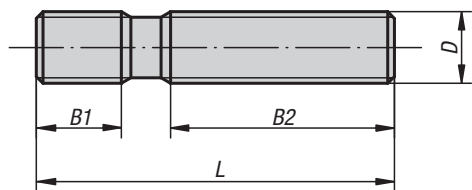

Material:
Carbon steel.

Version:
Thread rolled.
M6-M12 tempered to 10.9, black.
M14-M36 tempered to 8.8, black.

KIPP Studs DIN 6379

Order No.	D	L	B1	B2
K0697.0632	M6	32	9	16
K0697.0640	M6	40	9	20
K0697.0650	M6	50	9	30
K0697.0663	M6	63	9	40
K0697.0680	M6	80	9	50
K0697.06100	M6	100	9	63
K0697.0840	M8	40	11	20
K0697.0863	M8	63	11	40
K0697.0880	M8	80	11	50
K0697.08100	M8	100	11	63
K0697.08125	M8	125	11	75
K0697.08160	M8	160	11	100
K0697.1050	M10	50	13	25
K0697.1080	M10	80	13	50
K0697.10100	M10	100	13	75
K0697.10125	M10	125	13	75
K0697.10160	M10	160	13	100
K0697.10200	M10	200	13	125
K0697.1250	M12	50	15	25
K0697.1263	M12	63	15	32
K0697.1280	M12	80	15	50
K0697.12100	M12	100	15	63
K0697.12125	M12	125	15	75
K0697.12160	M12	160	15	100
K0697.12200	M12	200	15	125
K0697.1463	M14	63	17	32
K0697.1480	M14	80	17	50
K0697.14100	M14	100	17	63
K0697.14125	M14	125	17	75
K0697.14160	M14	160	17	100
K0697.14200	M14	200	17	125
K0697.14250	M14	250	17	160
K0697.1663	M16	63	19	32
K0697.1680	M16	80	19	50
K0697.16100	M16	100	19	63
K0697.16125	M16	125	19	75
K0697.16160	M16	160	19	100
K0697.16200	M16	200	19	125
K0697.16250	M16	250	19	160
K0697.16315	M16	315	19	180

Sample order:
K0697.12125

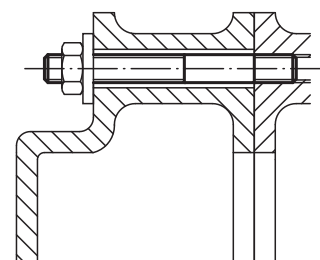

Studs

DIN 6379



Order No.	D	L	B1	B2
K0697.16350	M16	350	19	200
K0697.16500	M16	500	20	315
K0697.1880	M18	80	23	50
K0697.18125	M18	125	23	75
K0697.18160	M18	160	23	100
K0697.18200	M18	200	23	125
K0697.18250	M18	250	23	150
K0697.18315	M18	315	23	180
K0697.2080	M20	80	27	32
K0697.20125	M20	125	27	70
K0697.20160	M20	160	27	100
K0697.20200	M20	200	27	125
K0697.20250	M20	250	27	160
K0697.20315	M20	315	27	200
K0697.20400	M20	400	27	250
K0697.20500	M20	500	27	315
K0697.22100	M22	100	31	45
K0697.22160	M22	160	31	100
K0697.22200	M22	200	31	125
K0697.22250	M22	250	31	160
K0697.22315	M22	315	31	180
K0697.22400	M22	400	31	250
K0697.24100	M24	100	35	45
K0697.24125	M24	125	35	63
K0697.24160	M24	160	35	100
K0697.24200	M24	200	35	125
K0697.24250	M24	250	35	160
K0697.24315	M24	315	35	200
K0697.24400	M24	400	35	250
K0697.24500	M24	500	35	315
K0697.24630	M24	630	35	315
K0697.27125	M27	125	39	56
K0697.27200	M27	200	39	125
K0697.27315	M27	315	39	200
K0697.27400	M27	400	39	250
K0697.27500	M27	500	39	315
K0697.30125	M30	125	43	56
K0697.30200	M30	200	43	125
K0697.30315	M30	315	43	200
K0697.30500	M30	500	43	315
K0697.30700	M30	700	43	400
K0697.301000	M30	1000	44	400
K0697.36160	M36	160	51	80
K0697.36200	M36	200	51	125
K0697.36250	M36	250	51	160
K0697.36315	M36	315	51	200
K0697.36400	M36	400	51	250
K0697.36500	M36	500	51	315
K0697.36700	M36	700	51	400



T-slot bolts

DIN 787

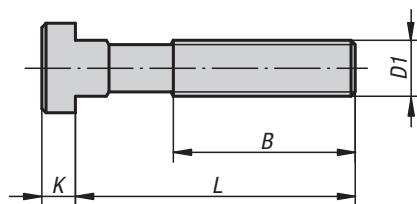
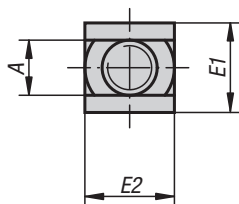

KIPP T-slot bolts DIN 787

Order No.	Nominal slot size	D1	L	A	B	E1/E2	K
K0698.0625	6	M6	25	5,7	15	10	4
K0698.0640	6	M6	40	5,7	28	10	4
K0698.0663	6	M6	63	5,7	40	10	4
K0698.0832	8	M8	32	7,7	22	13	6
K0698.0850	8	M8	50	7,7	35	13	6
K0698.0880	8	M8	80	7,7	50	13	6
K0698.1040	10	M10	40	9,7	30	15	6
K0698.1063	10	M10	63	9,7	45	15	6
K0698.10100	10	M10	100	9,7	60	15	6
K0698.1250	12	M12	50	11,7	35	18	7
K0698.1263	12	M12	63	11,7	40	18	7
K0698.1280	12	M12	80	11,7	55	18	7
K0698.12100	12	M12	100	11,7	65	18	7
K0698.12125	12	M12	125	11,7	75	18	7
K0698.12160	12	M12	160	11,7	100	18	7
K0698.12200	12	M12	200	11,7	120	18	7
K0698.1450	14	M12	50	13,7	35	22	8
K0698.1463	14	M12	63	13,7	45	22	8
K0698.1480	14	M12	80	13,7	55	22	8
K0698.14100	14	M12	100	13,7	65	22	8
K0698.14125	14	M12	125	13,7	75	22	8
K0698.14160	14	M12	160	13,7	100	22	8
K0698.14200	14	M12	200	13,7	120	22	8
K0698.16631	16	M14	63	15,7	45	25	9
K0698.16801	16	M14	80	15,7	55	25	9
K0698.161001	16	M14	100	15,7	65	25	9
K0698.161251	16	M14	125	15,7	75	25	9
K0698.161601	16	M14	160	15,7	100	25	9
K0698.162501	16	M14	250	15,7	150	25	9
K0698.1663	16	M16	63	15,7	45	25	9
K0698.1680	16	M16	80	15,7	55	25	9
K0698.16100	16	M16	100	15,7	65	25	9
K0698.16125	16	M16	125	15,7	85	25	9
K0698.16160	16	M16	160	15,7	100	25	9
K0698.16200	16	M16	200	15,7	125	25	9
K0698.16250	16	M16	250	15,7	150	25	9
K0698.1863	18	M16	63	17,7	45	28	10

Material:

Carbon steel.

Version:

Forged and milled, rolled thread.

M6-M12 tempered to 10.9, black.

M14-M36 tempered to 8.8, black.

Sample order:

K0698.1263

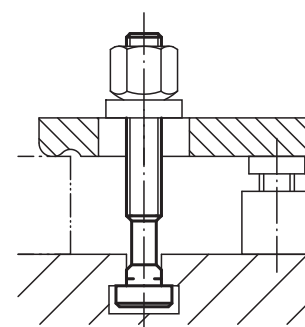

T-slot bolts

DIN 787



Order No.	Nominal slot size	D1	L	A	B	E1/E2	K
K0698.1880	18	M16	80	17,7	55	28	10
K0698.18100	18	M16	100	17,7	65	28	10
K0698.18125	18	M16	125	17,7	85	28	10
K0698.18160	18	M16	160	17,7	100	28	10
K0698.18200	18	M16	200	17,7	125	28	10
K0698.18250	18	M16	250	17,7	150	28	10
K0698.2080	20	M20	80	19,7	55	32	12
K0698.20100	20	M20	100	19,7	65	32	12
K0698.20125	20	M20	125	19,7	85	32	12
K0698.20160	20	M20	160	19,7	110	32	12
K0698.20200	20	M20	200	19,7	125	32	12
K0698.20250	20	M20	250	19,7	150	32	12
K0698.20315	20	M20	315	19,7	190	32	12
K0698.2280	22	M20	80	21,7	55	35	14
K0698.22100	22	M20	100	21,7	65	35	14
K0698.22125	22	M20	125	21,7	85	35	14
K0698.22160	22	M20	160	21,7	110	35	14
K0698.22200	22	M20	200	21,7	125	35	14
K0698.22250	22	M20	250	21,7	150	35	14
K0698.22315	22	M20	315	21,7	190	35	14
K0698.24100	24	M24	100	23,7	70	40	16
K0698.24125	24	M24	125	23,7	85	40	16
K0698.24160	24	M24	160	23,7	110	40	16
K0698.24200	24	M24	200	23,7	125	40	16
K0698.24250	24	M24	250	23,7	150	40	16
K0698.24315	24	M24	315	23,7	190	40	16
K0698.24400	24	M24	400	23,7	240	40	16
K0698.28100	28	M24	100	27,7	70	44	18
K0698.28125	28	M24	125	27,7	85	44	18
K0698.28160	28	M24	160	27,7	110	44	18
K0698.28200	28	M24	200	27,7	125	44	18
K0698.28250	28	M24	250	27,7	150	44	18
K0698.28315	28	M24	315	27,7	190	44	18
K0698.28400	28	M24	400	27,7	240	44	18
K0698.36125	36	M30	125	35,6	80	54	22
K0698.36160	36	M30	160	35,6	110	54	22
K0698.36200	36	M30	200	35,6	135	54	22
K0698.36250	36	M30	250	35,6	150	54	22
K0698.36315	36	M30	315	35,6	200	54	22
K0698.36500	36	M30	500	35,6	300	54	22
K0698.42160	42	M36	160	41,6	100	65	26
K0698.42250	42	M36	250	41,6	175	65	26
K0698.42400	42	M36	400	41,6	250	65	26



T-slot bolts

DIN 787, 12.9

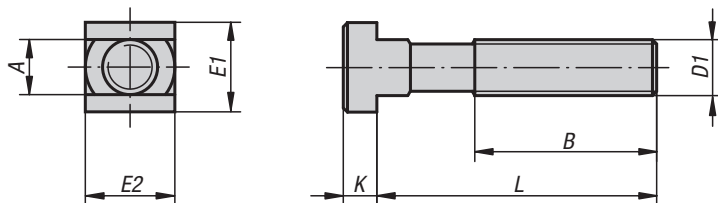

KIPP T-slot bolts DIN 787, 12.9

Order No.	Nominal slot size	D1	L	A	B	E1/E2	K
K0699.11250	12	M12	50	11,7	35	18	7
K0699.11280	12	M12	80	11,7	55	18	7
K0699.112100	12	M12	100	11,7	65	18	7
K0699.112125	12	M12	125	11,7	75	18	7
K0699.112160	12	M12	160	11,7	100	18	7
K0699.112200	12	M12	200	11,7	120	18	7
K0699.11450	14	M12	50	13,7	35	22	8
K0699.11480	14	M12	80	13,7	55	22	8
K0699.114100	14	M12	100	13,7	65	22	8
K0699.114125	14	M12	125	13,7	75	22	8
K0699.114160	14	M12	160	13,7	100	22	8
K0699.114200	14	M12	200	13,7	120	22	8
K0699.11663	16	M16	63	15,7	45	25	9
K0699.116100	16	M16	100	15,7	65	25	9
K0699.116125	16	M16	125	15,7	85	25	9
K0699.116160	16	M16	160	15,7	100	25	9
K0699.116250	16	M16	250	15,7	150	25	9
K0699.11863	18	M16	63	17,7	45	28	10
K0699.118100	18	M16	100	17,7	65	28	10
K0699.118125	18	M16	125	17,7	85	28	10
K0699.118160	18	M16	160	17,7	100	28	10
K0699.118250	18	M16	250	17,7	150	28	10
K0699.12080	20	M20	80	19,7	55	32	12
K0699.120125	20	M20	125	19,7	85	32	12
K0699.120200	20	M20	200	19,7	125	32	12
K0699.120315	20	M20	315	19,7	190	32	12
K0699.12280	22	M20	80	21,7	55	35	14
K0699.122125	22	M20	125	21,7	85	35	14
K0699.122200	22	M20	200	21,7	125	35	14
K0699.122315	22	M20	315	21,7	190	35	14
K0699.124100	24	M24	100	23,7	70	40	16
K0699.124160	24	M24	160	23,7	110	40	16
K0699.124250	24	M24	250	23,7	150	40	16
K0699.124400	24	M24	400	23,7	240	40	16
K0699.128100	28	M24	100	27,7	70	44	18
K0699.128160	28	M24	160	27,7	110	44	18
K0699.128250	28	M24	250	27,7	150	44	18
K0699.128400	28	M24	400	27,7	240	44	18

Material:

Carbon steel.

Version:

Forged and milled, rolled thread, tempered to 12.9, black.

Sample order:

K0699.112125

Hexagon head bolts with flange

EN 1665

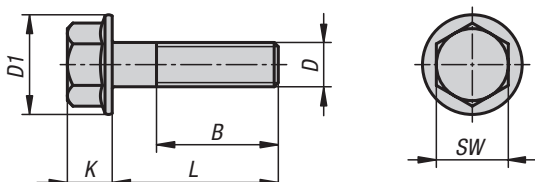
**Material:**

Steel or stainless steel (A 2)

Version:Steel grade 8.8, galvanized.
Steel grade 10.9, galvanized.
Bright stainless steel.**Sample order:**

K1161.406X12 (include length L)

KIPP Hexagon head screws with flange EN 1665

Order No.	Main material	Grade	D	L	B	D1	SW	K
K1161.406X	steel	8.8	M6	12/16/20/25/30	18	14,2	10	6,6
K1161.408X	steel	8.8	M8	12/16/20/25/30/35/40/50/60	22	18	13	8,1
K1161.410X	steel	8.8	M10	20/25/30/35/40/50	26	22,3	15	9,2
K1161.412X	steel	8.8	M12	20/25/30/40/50	30	26,6	16	11,5
K1161.416X	steel	8.8	M16	30/35/40/45/50/70	38	35	21	14,4
K1161.506X	steel	10.9	M6	12/16/20/25/30	18	14,2	10	6,6
K1161.508X	steel	10.9	M8	12/16/20/25/30/35/40	22	18	13	8,1
K1161.510X	steel	10.9	M10	25/30/40	26	22,3	15	9,2
K1161.512X	steel	10.9	M12	20/35/40/45/50	30	26,6	16	11,5
K1161.516X	steel	10.9	M16	30/35/40/45/50/60	38	35	21	14,4
K1161.106X	stainless steel	-	M6	12/16/20/25/30	18	14,2	10	6,6
K1161.108X	stainless steel	-	M8	16/20/25/30/35/40/50	22	18	13	8,1
K1161.110X	stainless steel	-	M10	20/25/30/35/40/50/60	26	22,3	15	9,2



Hexagon head bolts

DIN 931/DIN EN ISO 4014/DIN EN 24014

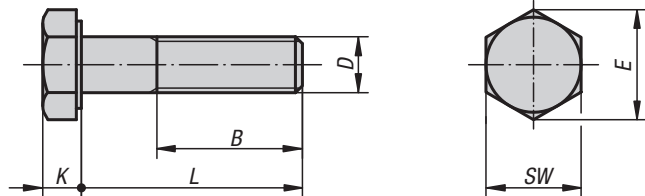
**Material:**

Steel or stainless steel (A 2)

Version:

Steel grade 8.8, black or galvanised.
 Steel grade 10.9, black or galvanised.
 Steel grade 12.9, black.
 Stainless steel A 2-70, bright.

Sample order:

K0870.110X50 (include length L)

On request:

DIN ISO 272 spanner sizes.

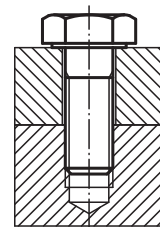

KIPP Hexagon head bolts DIN 931/DIN EN ISO 4014/DIN EN 24014

Order No. steel Grade 8.8	Order No. steel Grade 10.9	Surface	D	L	B	SW	E	K
K0870.04X	-	-	M4	25/30/35/40/45/50	14	7	7,66	2,8
K0870.05X	-	-	M5	25/30/35/40/45/50/60	16	8	8,79	3,5
K0870.06X	K0870.306X	-	M6	30/35/40/45/50/60/70	18	10	11,05	4
K0870.08X	K0870.308X	-	M8	35/40/45/50/60/70/80	22	13	14,38	5,3
K0870.10X	K0870.310X	-	M10	40/45/50/60/70/80/90/100	26	17	18,9	6,4
K0870.12X	K0870.312X	-	M12	45/50/60/70/80/90/100/110/120	30	19	21,1	7,5
K0870.16X	K0870.316X	-	M16	60/70/80/90/100/110/120	38	24	26,75	10
K0870.20X	K0870.320X	-	M20	70/80/90/100/110/120	46	30	33,53	12,5
K0870.404X	-	Galvanized	M4	25/30/35/40/45/50	14	7	7,66	2,8
K0870.405X	-	Galvanized	M5	25/30/35/40/45/50/60	16	8	8,79	3,5
K0870.406X	K0870.506X	Galvanized	M6	30/35/40/45/50/60/70	18	10	11,05	4
K0870.408X	K0870.508X	Galvanized	M8	35/40/45/50/60/70/80	22	13	14,38	5,3
K0870.410X	K0870.510X	Galvanized	M10	40/45/50/60/70/80/90/100	26	17	18,9	6,4
K0870.412X	K0870.512X	Galvanized	M12	45/50/60/70/80/90/100/110/120	30	19	21,1	7,5
K0870.416X	K0870.516X	Galvanized	M16	60/70/80/90/100/110/120	38	24	26,75	10
K0870.420X	K0870.520X	Galvanized	M20	70/80/90/100/110/120	46	30	33,53	12,5

Hexagon head bolts

DIN 931/DIN EN ISO 4014/DIN EN 24014



Order No.	Main material	Grade	D	L	B	SW	E	K
K0870.210X	steel	12.9	M10	40/45/50/60/70/80/90/100	26	17	18,9	6,4
K0870.212X	steel	12.9	M12	45/50/60/70/80/90/100/120	30	19	21,1	7,5
K0870.216X	steel	12.9	M16	60/70/80/90/100/120	38	24	26,75	10
K0870.220X	steel	12.9	M20	70/80/90/100/120	46	30	33,53	12,5

Order No.	Main material	D	L	B	SW	E	K
K0870.105X	stainless steel	M5	25/30/35/40/45/50/60	16	8	8,79	3,5
K0870.106X	stainless steel	M6	30/35/40/45/50/60/70	18	10	11,05	4
K0870.108X	stainless steel	M8	35/40/45/50/60/70/80	22	13	14,38	5,3
K0870.110X	stainless steel	M10	40/45/50/60/70/80/90/100	26	17	18,9	6,4
K0870.112X	stainless steel	M12	45/50/60/70/80/90/100/110/120	30	19	21,1	7,5
K0870.116X	stainless steel	M16	60/70/80/90/100/110/120	38	24	26,75	10

Hexagon head bolts

DIN 933

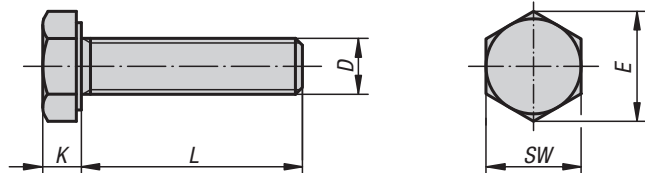
**Material:**

Steel or stainless steel (A 2)

Version:

Steel grade 8.8, black or galvanised.
 Steel grade 10.9, black or galvanised.
 Steel grade 12.9, black.
 Stainless steel A 2-70, bright.

Sample order:

K0871.05X40 (include length L)

KIPP Hexagon head bolts DIN 933

Order No. steel Grade 8.8	Order No. steel Grade 10.9	Surface	D	L	K	SW	E
K0871.04X	-	-	M4	10/12/16/18/20/25	2,8	7	7,66
K0871.05X	-	-	M5	10/12/16/18/20/25/30/35/40	3,5	8	8,79
K0871.06X	K0871.306X	-	M6	10/12/16/18/20/25/30/35/40/45/50/55/60	4	10	11,05
K0871.08X	K0871.308X	-	M8	16/18/20/25/30/35/40/45/50/60/70/80/90/100	5,3	13	14,38
K0871.10X	K0871.310X	-	M10	16/18/20/25/30/35/40/45/50/60/70/80/90/100	6,4	17	18,9
K0871.12X	K0871.312X	-	M12	20/25/30/35/40/45/50/60/70/80/90/100/110/120	7,5	19	21,1
K0871.14X	-	-	M14	30/35/40/45/50/60/70/80/90/100/110/120	8,8	22	24,49
K0871.16X	K0871.316X	-	M16	30/35/40/45/50/60/70/80/90/100/110/120	10	24	26,75
K0871.20X	K0871.320X	-	M20	40/45/50/60/70/80/90/100/110/120	12,5	30	33,53
K0871.404X	-	Galvanized	M4	10/12/16/18/20/25	2,8	7	7,66
K0871.405X	-	Galvanized	M5	10/12/16/18/20/25/30/35/40	3,5	8	8,79
K0871.406X	K0871.506X	Galvanized	M6	10/12/16/18/20/25/30/35/40/45/50/55/60	4	10	11,05
K0871.408X	K0871.508X	Galvanized	M8	16/18/20/25/30/35/40/45/50/60/70/80/90/100	5,3	13	14,38
K0871.410X	K0871.510X	Galvanized	M10	16/18/20/25/30/35/40/45/50/60/70/80/90/100	6,4	17	18,9
K0871.412X	K0871.512X	Galvanized	M12	20/25/30/35/40/45/50/60/70/80/90/100/110/120	7,5	19	21,1
K0871.414X	-	Galvanized	M14	30/35/40/45/50/60/70/80/90/100/110/120	8,8	22	24,49
K0871.416X	K0871.516X	Galvanized	M16	30/35/40/45/50/60/70/80/90/100/110/120	10	24	26,75
K0871.420X	K0871.520X	Galvanized	M20	40/45/50/60/70/80/90/100/110/120	12,5	30	33,53

Hexagon head bolts

DIN 933



Order No.	Main material	Grade	D	L	SW	E	K
K0871.206X	steel	12.9	M6	12/16/20/25/30	10	11,05	4
K0871.208X	steel	12.9	M8	16/20/25/30/35/40/45/50/60	13	14,38	5,3
K0871.210X	steel	12.9	M10	20/25/30/35/40/45/50/60	17	18,9	6,4
K0871.212X	steel	12.9	M12	25/30/35/40/45/50/60	19	21,1	7,5
K0871.216X	steel	12.9	M16	30/35/40/45/50/60/70/80/90/100	24	26,75	10
K0871.220X	steel	12.9	M20	40/45/50/60/70/80/90/100	30	33,53	12,5

Order No.	Main material	D	L	SW	E	K
K0871.104X	stainless steel	M4	10/12/16/18/20/25	7	7,66	2,8
K0871.105X	stainless steel	M5	10/12/16/18/20/25/30/35/40	8	8,79	3,5
K0871.106X	stainless steel	M6	10/12/16/18/20/25/30/35/40/45/50/55/60	10	11,05	4
K0871.108X	stainless steel	M8	16/18/20/25/30/35/40/45/50/60/70/80/90/100	13	14,38	5,3
K0871.110X	stainless steel	M10	16/18/20/25/30/35/40/45/50/60/70/80/90/100	17	18,9	6,4
K0871.112X	stainless steel	M12	20/25/30/35/40/45/50/60/70/80/90/100/110/120	19	21,1	7,5
K0871.116X	stainless steel	M16	30/35/40/45/50/60/70/80/90/100/110/120	24	26,75	10
K0871.120X	stainless steel	M20	40/45/50/60/70/80/90/100/110/120	30	33,53	12,5

Hexagon nuts thin

DIN 439

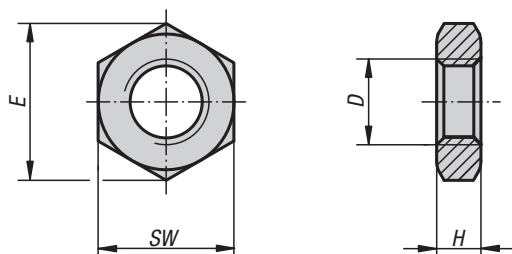
**Material:**

Steel or stainless steel (A 2)

Version:Steel grade 04, galvanized or black oxidised.
Stainless steel A2, bright.**Sample order:**

K0700.10

Note:

These hexagon nuts are used in screw connections exposed to limited loads, e.g. as a locknut for clevis joints or rod ends.

KIPP Hexagon nuts thin DIN 439

Order No. steel galvanised	Order No. stainless steel bright	Order No. steel black oxidised	Version	D	E	H	SW
K0700.05	K0700.105	K0700.205	RH thread	M5	8,79	2,7	8
K0700.06	K0700.106	K0700.206	RH thread	M6	11,05	3,2	10
K0700.006	K0700.1062	K0700.2063	RH thread	M6x0,75	11,05	3,2	10
K0700.08	K0700.108	K0700.208	RH thread	M8	14,38	4	13
K0700.008	K0700.1083	K0700.2083	RH thread	M8x1	14,38	4	13
K0700.10	K0700.110	K0700.210	RH thread	M10	18,9	5	17
K0700.103	K0700.1103	K0700.2103	RH thread	M10x1	18,9	5	17
K0700.104	K0700.1104	-	RH thread	M10x1,25	18,9	5	17
K0700.12	K0700.112	K0700.212	RH thread	M12	21,1	6	19
K0700.123	K0700.1123	-	RH thread	M12x1,25	21,1	6	19
K0700.124	K0700.1124	K0700.2124	RH thread	M12x1,5	21,1	6	19
K0700.14	K0700.114	-	RH thread	M14	24,49	7	22
K0700.16	K0700.116	K0700.216	RH thread	M16	26,76	8	24
K0700.163	K0700.1163	K0700.2163	RH thread	M16x1,5	26,76	8	24
K0700.183	-	-	RH thread	M18x1,5	29,56	9	27
K0700.20	K0700.120	-	RH thread	M20	32,95	10	30
K0700.203	K0700.1203	K0700.2203	RH thread	M20x1,5	32,95	10	30
K0700.223	K0700.1223	-	RH thread	M22x1,5	36,9	10	32
K0700.24	K0700.1244	-	RH thread	M24	39,55	12	36
-	K0700.1243	K0700.2243	RH thread	M24x2	39,6	12	36
K0700.30	-	-	RH thread	M30	50,85	15	46
K0700.061	K0700.1061	-	LH thread	M6	11,05	3,2	10
K0700.081	K0700.1081	-	LH thread	M8	14,38	4	13
K0700.101	K0700.1101	-	LH thread	M10	18,9	5	17
K0700.1031	K0700.11031	-	LH thread	M10x1	18,9	5	17
K0700.1041	K0700.11041	-	LH thread	M10x1,25	18,9	5	17
K0700.121	K0700.1121	-	LH thread	M12	21,1	6	19
K0700.1231	K0700.11231	-	LH thread	M12x1,25	21,1	6	19
K0700.1241	K0700.11241	-	LH thread	M12x1,5	21,1	6	19
K0700.161	K0700.1161	-	LH thread	M16	26,76	8	24
K0700.2031	K0700.12031	-	LH thread	M20x1,5	32,95	10	30
K0700.2231	K0700.12231	-	LH thread	M22x1,5	36,9	10	32

Hexagon nuts with polyamide thread lock

high type, DIN 982

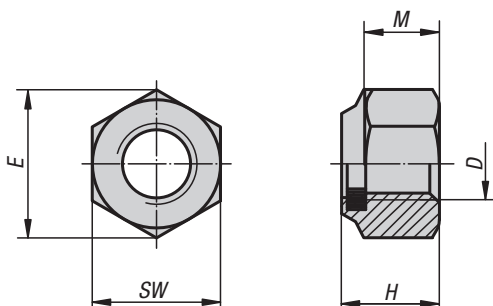

Material:

Steel or stainless steel (A 2)

Version:

Galvanised steel.

Bright stainless steel.

Sample order:

K1147.204

Note:

When screwing the nuts onto the thread, the thread lock is plastically and elastically deformed. The elastic deformation causes a radial frictional lock against the nuts being loosened.

The plastic thread lock is only effective when the nuts are fully screwed onto the male thread. The screw length must be selected so that at least two full threads protrude from the nut.

Due to the plastic deformation of the thread lock, these nuts should only be used once.

Temperature range:

-50°C to +120°C.

KIPP Hexagon nuts with polyamide thread lock, high type DIN 982

Order No.	Main material	Grade	D	E	H	M	SW
K1147.204	steel	6-8	M4	7,66	6	2,9	7
K1147.205	steel	8	M5	8,79	6,3	4,4	8
K1147.206	steel	8	M6	11,05	8	4,9	10
K1147.208	steel	8	M8	14,38	9,5	6,44	13
K1147.210	steel	8	M10	18,9	11,5	8,04	17
K1147.212	steel	8	M12	21,1	14	10,37	19
K1147.214	steel	8	M14	23,9	16	12,1	22
K1147.216	steel	8	M16	26,76	18	14,1	24
K1147.220	steel	8	M20	32,95	22	16,9	30
K1147.224	steel	8	M24	39,55	28	20,2	36
K1147.310	steel	10	M10	18,9	11,5	8,04	17
K1147.312	steel	10	M12	21,1	14	10,37	19
K1147.316	steel	10	M16	26,76	18	14,1	24
K1147.320	steel	10	M20	32,95	22	16,9	30
K1147.324	steel	10	M24	39,55	28	20,2	36
K1147.105	stainless steel	-	M5	8,79	6,3	4,4	8
K1147.106	stainless steel	-	M6	11,05	8	4,9	10
K1147.108	stainless steel	-	M8	14,38	9,5	6,44	13
K1147.110	stainless steel	-	M10	18,9	11,5	8,04	17
K1147.112	stainless steel	-	M12	21,1	14	10,37	19
K1147.116	stainless steel	-	M16	26,76	18	14,1	24
K1147.120	stainless steel	-	M20	32,95	22	16,9	30



K1145

Hexagon nuts

DIN 934/DIN EN ISO 4032/DIN EN 24032

**Material:**

Steel or stainless steel (A 2)

Version:

Steel grade 8, bright or galvanised.
 Steel grade 10, bright or galvanised.
 Steel grade 12, bright.
 Stainless steel A 2-70, bright.

Sample order:

K1145.10

Note:

The nut grade must always be the same or higher than the bolt grade, i.e. bolts with grade 8.8 are always paired with nuts grade 8 or higher, but never less.

On request:

DIN ISO 272 spanner sizes.

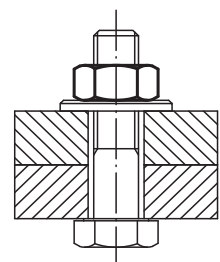
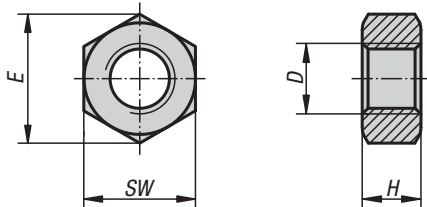

Hexagon nuts

DIN 934/DIN EN ISO 4032/DIN EN 24032



KIPP Hexagon nuts DIN 934/DIN EN ISO 4032/DIN EN 24032

Order No. steel Grade 8	Order No. steel Grade 10	Order No. steel Grade 12	Order No. stainless steel Grade 70	Surface	D	E	H	SW
K1145.03	K1145.403	-	K1145.103	bright	M3	6,01	2,4	5,5
K1145.04	K1145.404	-	K1145.104	bright	M4	7,66	3,2	7
K1145.05	K1145.405	-	K1145.105	bright	M5	8,79	4	8
K1145.06	K1145.406	K1145.506	K1145.106	bright	M6	11,05	5	10
K1145.08	K1145.408	K1145.508	K1145.108	bright	M8	14,38	6,5	13
K1145.10	K1145.410	K1145.510	K1145.110	bright	M10	18,9	8	17
K1145.12	K1145.412	K1145.512	K1145.112	bright	M12	21,1	10	19
K1145.14	K1145.414	-	K1145.114	bright	M14	23,9	11	22
K1145.16	K1145.416	K1145.516	K1145.116	bright	M16	26,76	13	24
K1145.20	K1145.420	K1145.520	K1145.120	bright	M20	32,95	16	30
K1145.22	K1145.422	-	K1145.122	bright	M22	35	18	32
K1145.24	K1145.424	K1145.524	K1145.124	bright	M24	39,6	19	36
K1145.27	K1145.427	K1145.527	K1145.127	bright	M27	45,2	22	41
K1145.30	K1145.430	K1145.530	K1145.130	bright	M30	50,9	24	46
K1145.33	K1145.433	-	K1145.133	bright	M33	55,4	26	50
K1145.36	K1145.436	K1145.536	K1145.136	bright	M36	60,8	29	55
K1145.203	-	-	-	galvanised	M3	6,01	2,4	5,5
K1145.204	K1145.304	-	-	galvanised	M4	7,66	3,2	7
K1145.205	K1145.305	-	-	galvanised	M5	8,79	4	8
K1145.206	K1145.306	-	-	galvanised	M6	11,05	5	10
K1145.208	K1145.308	-	-	galvanised	M8	14,38	6,5	13
K1145.210	K1145.310	-	-	galvanised	M10	18,9	8	17
K1145.212	K1145.312	-	-	galvanised	M12	21,1	10	19
K1145.214	K1145.314	-	-	galvanised	M14	23,9	11	22
K1145.216	K1145.316	-	-	galvanised	M16	26,76	13	24
K1145.220	K1145.320	-	-	galvanised	M20	32,95	16	30
K1145.222	K1145.322	-	-	galvanised	M22	35	18	32
K1145.224	K1145.324	-	-	galvanised	M24	39,6	19	36
K1145.227	K1145.327	-	-	galvanised	M27	45,2	22	41
K1145.230	K1145.330	-	-	galvanised	M30	50,9	24	46
K1145.233	K1145.333	-	-	galvanised	M33	55,4	26	50
K1145.236	K1145.336	-	-	galvanised	M36	60,8	29	55



Hexagon nuts with polyamide thread lock

thin type, DIN 985

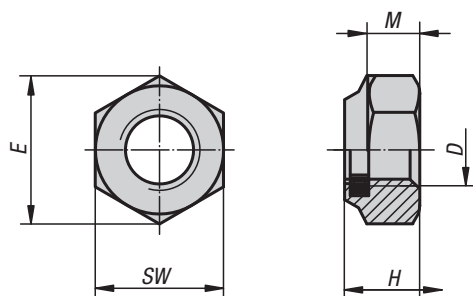
Material:

Steel or stainless steel (A 2)

Version:

Galvanised steel.

Bright stainless steel.

Sample order:

K1148.203

Note:

When screwing the nuts onto the thread, the thread lock is plastically and elastically deformed. The elastic deformation causes a radial frictional lock against the nuts being loosened.

The plastic thread lock is only effective when the nuts are fully screwed onto the male thread. The screw length must be selected so that at least two full threads protrude from the nut.

Due to the plastic deformation of the thread lock, these nuts should only be used once.

Temperature range:

-50°C to +120°C.

KIPP Hexagon nuts with polyamide thread lock, thin type DIN 985

Order No. steel Grade 6-8	Order No. steel Grade 8	Order No. steel Grade 10	D	E	H	M	SW
K1148.203	-	-	M3	6,08	4	2,4	5,5
K1148.204	-	-	M4	7,66	5	2,9	7
K1148.205	-	-	M5	8,79	5	3,2	8
-	K1148.206	K1148.306	M6	11,05	6	4	10
-	K1148.208	K1148.308	M8	14,38	8	5,5	13
-	K1148.210	K1148.310	M10	18,9	10	6,5	17
-	K1148.212	K1148.312	M12	21,1	12	8	19
-	K1148.214	K1148.314	M14	23,9	14	9,5	22
-	K1148.216	K1148.316	M16	26,76	16	10,5	24
-	K1148.220	K1148.320	M20	32,95	20	14	30
-	K1148.224	-	M24	39,55	24	15	36
-	K1148.227	K1148.327	M27	45,2	27	17	41
-	K1148.230	K1148.330	M30	50,85	30	19	46
-	-	K1148.324	M24	35	24	15	36

Hexagon nuts with polyamide thread lock

thin type, DIN 985



Order No.	Main material	D	E	H	M	SW
K1148.103	stainless steel	M3	6,08	4	2,4	5,5
K1148.104	stainless steel	M4	7,66	5	2,9	7
K1148.105	stainless steel	M5	8,79	5	3,2	8
K1148.106	stainless steel	M6	11,05	6	4	10
K1148.108	stainless steel	M8	14,38	8	5,5	13
K1148.110	stainless steel	M10	18,9	10	6,5	17
K1148.112	stainless steel	M12	21,1	12	8	19
K1148.114	stainless steel	M14	23,9	14	9,5	22
K1148.116	stainless steel	M16	26,76	16	10,5	24
K1148.120	stainless steel	M20	32,95	20	14	30
K1148.124	stainless steel	M24	39,55	24	15	36
K1148.127	stainless steel	M27	45,2	27	17	41
K1148.130	stainless steel	M30	50,85	30	19	46



Hexagon nuts with thread lock

DIN 980

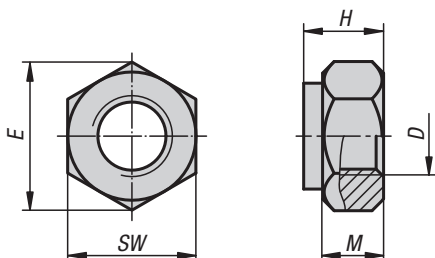
**Material:**

Steel or stainless steel (A 2)

Version:

Galvanised steel.

Bright stainless steel.

Sample order:

K1146.204

Note:

Hexagon nuts with thread lock DIN 980, Form V (all-metal nut, one piece).

KIPP Hexagon nuts with thread lock DIN 980

Order No. steel Grade 8	Order No. steel Grade 10	D	E	H	M	SW
K1146.204	-	M4	7,66	4,2	2,2	7
K1146.205	-	M5	8,79	5,1	2,75	8
K1146.206	-	M6	11,05	6	3,3	10
K1146.208	K1146.308	M8	14,38	8	4,4	13
K1146.210	K1146.310	M10	18,9	10	5,5	17
K1146.212	K1146.312	M12	21,1	12	6,6	19
K1146.214	K1146.314	M14	23,9	14	7,7	22
K1146.216	K1146.316	M16	26,76	16	8,8	24
K1146.220	K1146.320	M20	32,95	20	11	30
K1146.224	K1146.324	M24	39,55/35	24	13,2	36
K1146.227	K1146.327	M27	45,2	27	14,8	41
K1146.230	K1146.330	M30	50,85	30	16,5	46

Order No.	Main material	D	E	H	M	SW
K1146.104	stainless steel	M4	7,66	4,2	2,2	7
K1146.105	stainless steel	M5	8,79	5,1	2,75	8
K1146.106	stainless steel	M6	11,05	6	3,3	10
K1146.108	stainless steel	M8	14,38	8	4,4	13
K1146.110	stainless steel	M10	18,9	10	5,5	17
K1146.112	stainless steel	M12	21,1	12	6,6	19
K1146.114	stainless steel	M14	23,9	14	7,7	22
K1146.116	stainless steel	M16	26,76	16	8,8	24
K1146.120	stainless steel	M20	32,95	20	11	30
K1146.124	stainless steel	M24	39,55	24	13,2	36

Hexagon nuts with collar

height 1.5xD, DIN 6331 enhanced

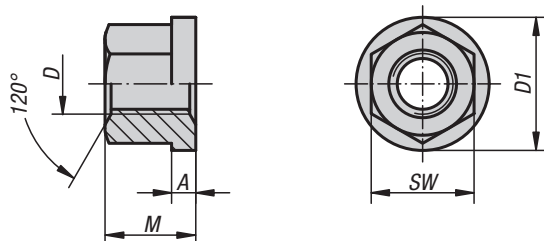
Material:

Carbon steel or stainless steel 1.4301.

Version:

Steel grade 10, black.
Stainless steel bright.

Sample order:

K0701.16

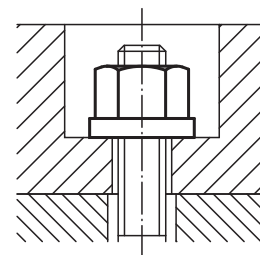

KIPP Hexagon nuts with collar height 1.5xD, DIN 6331 enhanced

Order No. high carbon steel -	Order No. stainless steel 1.4301	D	M = 1,5 x D	A	D1	SW
K0701.05	-	M5	7,5	2	12	9
K0701.06	K0701.806	M6	9	3	14	10
K0701.08	K0701.808	M8	12	3,5	18	13
K0701.10	K0701.810	M10	15	4	22	16
K0701.101	K0701.811	M10	15	4	22	17
K0701.12	K0701.812	M12	18	4	25	18
K0701.121	K0701.8121	M12	18	4	25	19
K0701.14	-	M14	21	4,5	28	22
K0701.16	K0701.816	M16	24	5	31	24
K0701.18	-	M18	27	5	34	27
K0701.20	K0701.820	M20	30	6	37	30
K0701.22	-	M22	33	6	40	34
K0701.24	-	M24	36	6	45	36
K0701.30	-	M30	45	8	58	46
K0701.36	-	M36	54	10	68	55



Hexagon nuts

height 1.5xD, DIN 6330 enhanced

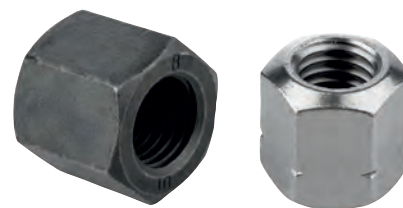
**Material:**

Carbon steel or stainless steel (A2).

Version:

Tempered to 10, black.

Stainless steel A 2-70, bright.

Sample order:

K0702.12

Note:

These hexagon nuts can be used with the conical seats K0729, Form D and G.

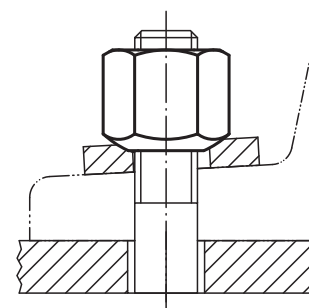
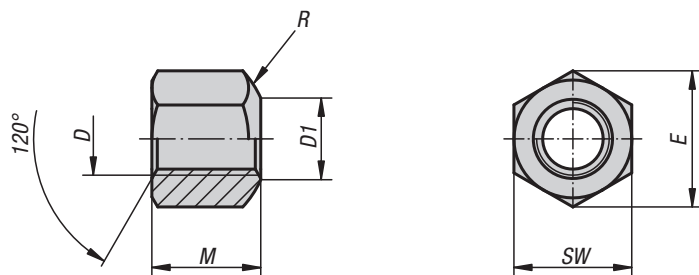

KIPP Hexagon nuts height 1.5xD, DIN 6330 enhanced

Order No.	Main material	D	M = 1,5 x D	D1	SW	E	R
K0702.05	carbon steel	M5	7,5	6,5	9	10,4	7
K0702.06	carbon steel	M6	9	7	10	11,5	9
K0702.08	carbon steel	M8	12	9	13	15	11
K0702.10	carbon steel	M10	15	11,5	16	18,4	15
K0702.101	carbon steel	M10	15	11,5	17	19,6	15
K0702.12	carbon steel	M12	18	14	18	20,7	17
K0702.121	carbon steel	M12	18	14	19	21,9	17
K0702.14	carbon steel	M14	21	16	22	25,4	20
K0702.16	carbon steel	M16	24	18	24	27,7	22
K0702.18	carbon steel	M18	27	20	27	31,2	24,5
K0702.20	carbon steel	M20	30	22	30	34,6	27
K0702.22	carbon steel	M22	33	24	32	36,9	29
K0702.24	carbon steel	M24	36	26	36	41,6	32
K0702.30	carbon steel	M30	45	32	46	53,1	41
K0702.36	carbon steel	M36	54	38	55	63,5	50
K0702.806	stainless steel	M6	9	7	10	11,5	9
K0702.808	stainless steel	M8	12	9	13	15	11
K0702.810	stainless steel	M10	15	11,5	16	18,4	15
K0702.811	stainless steel	M10	15	11,5	17	19,6	15
K0702.812	stainless steel	M12	18	14	18	20,7	17
K0702.816	stainless steel	M16	24	18	24	27,7	22
K0702.820	stainless steel	M20	30	22	30	34,6	27

K0794

Hexagon nuts

with spherical seat

**Material:**

Carbon steel or stainless steel.

Version:

Steel version:

tempered to 900 N/mm², black oxidised.

Stainless steel version:

Tempered to 900 N/mm², bright.**Sample order:**

K0794.12

Note:

Captive components (one-piece).

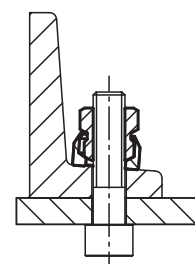
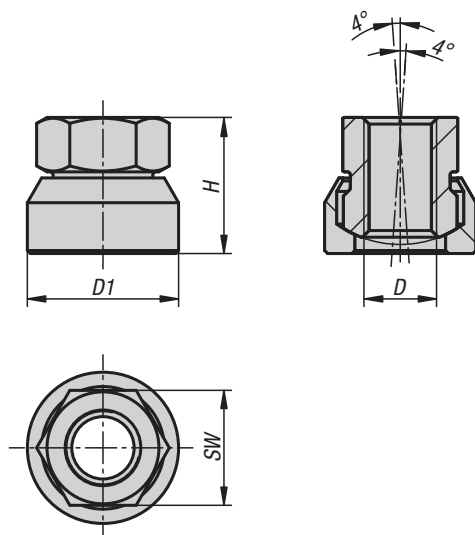

KIPP Hexagon nuts with spherical seat

Order No.	Main material	D	D1	H	SW
K0794.08	steel	M8	18	15	13
K0794.10	steel	M10	22	18,5	17
K0794.12	steel	M12	25	22,5	19
K0794.16	steel	M16	31	29	24
K0794.808	stainless steel	M8	18	15	13
K0794.810	stainless steel	M10	22	18,5	17
K0794.812	stainless steel	M12	25	22,5	19
K0794.816	stainless steel	M16	31	29	24

Washers with large OD

DIN 9021

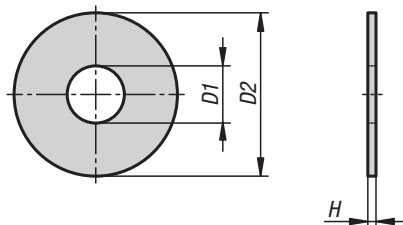
**Material:**

Steel or stainless steel (A 2)

Version:

Galvanised steel, hardness

D1 ≤ 14 = 140 HV.

D1 > 17 = 100 HV.

Stainless steel, bright.

Sample order:

K1150.03

Note:The pulleys have an OD of $D2 = \sim 3 \times D1$.

KIPP Washers with large OD DIN 9021

Order No. steel	Order No. stainless steel	for screws	D1	D2	H
K1150.03	K1150.103	M3	3,2	9	0,8
K1150.04	K1150.104	M4	4,3	12	1
K1150.05	K1150.105	M5	5,3	15	1,2
K1150.06	K1150.106	M6	6,4	18	1,6
K1150.08	K1150.108	M8	8,4	24	2
K1150.10	K1150.110	M10	10,5	30	2,5
K1150.12	K1150.112	M12	13	37	3
K1150.14	K1150.114	M14	15	44	3
K1150.16	K1150.116	M16	17	50	3
K1150.18	K1150.118	M18	20	56	4
K1150.20	K1150.120	M20	22	60	4
K1150.24	K1150.124	M24	26	72	5
K1150.30	-	M30	33	92	6

Shim washers

DIN 988

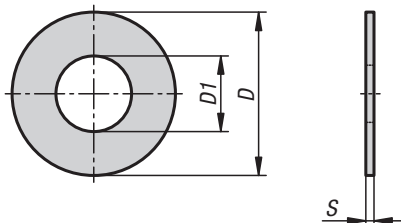
**Material:**

Steel.

Version:

Bright.

Sample order:

K1151.0306010

(include dimension S e.g. 010 for S = 0,1 mm.)

Note:

With shim washers, an existing axial backlash can be significantly reduced. They are available with a thicknesses from 0.1 mm. Any thicknesses can be made by combining several shim washers.

KIPP Shim washers DIN 988

Order No.	Main material	D	D1	S
K1151.0306***	steel	6	3	0,1/0,15/0,2/0,25/0,3/0,5/1
K1151.0408***	steel	8	4	0,1/0,15/0,2/0,3/0,5/1
K1151.0510***	steel	10	5	0,1/0,15/0,2/0,25/0,3/0,5/1
K1151.0612***	steel	12	6	0,1/0,2/0,25/0,3/0,5/1
K1151.0713***	steel	13	7	0,1/0,2/0,3/0,5/1
K1151.0814***	steel	14	8	0,1/0,15/0,2/0,25/0,3/0,5/1
K1151.0915***	steel	15	9	0,1/0,15/0,2/0,3/0,5/1
K1151.1016***	steel	16	10	0,1/0,15/0,2/0,25/0,3/0,5/1
K1151.1117***	steel	17	11	0,1/0,2/0,25/0,3/0,5/1
K1151.1218***	steel	18	12	0,1/0,15/0,2/0,25/0,3/0,5/1
K1151.1319***	steel	19	13	0,1/0,15/0,2/0,25/0,3/0,5/1
K1151.1420***	steel	20	14	0,1/0,15/0,2/0,25/0,3/0,5/1
K1151.1521***	steel	21	15	0,1/0,15/0,2/0,25/0,3/0,5/1/1,2
K1151.1622***	steel	22	16	0,15/0,2/0,25/0,3/0,5/1/1,2
K1151.1724***	steel	24	17	0,1/0,15/0,2/0,25/0,3/0,5/1/1,2
K1151.1825***	steel	25	18	0,1/0,15/0,2/0,25/0,3/0,5/1/1,2
K1151.1926***	steel	26	19	0,1/0,15/0,2/0,25/0,3/0,5/1/1,2
K1151.2028***	steel	28	20	0,1/0,15/0,2/0,25/0,3/0,5/1/1,2/1,5
K1151.2230***	steel	30	22	0,1/0,15/0,2/0,25/0,3/0,5/1/1,2/1,5
K1151.2535***	steel	35	25	0,1/0,15/0,2/0,25/0,3/0,5/1/1,2/1,5
K1151.2637***	steel	37	26	0,1/0,15/0,2/0,25/0,3/0,5/1/1,2/1,5
K1151.2840***	steel	40	28	0,1/0,15/0,2/0,25/0,3/0,5/1/1,2/1,5
K1151.3042***	steel	42	30	0,1/0,15/0,2/0,25/0,3/0,5/1/1,2/1,5/2
K1151.3245***	steel	45	32	0,1/0,15/0,2/0,25/0,3/0,5/1/1,2/1,5/2
K1151.3545***	steel	45	35	0,1/0,15/0,2/0,25/0,3/0,5/1/1,2/1,5/2
K1151.3645***	steel	45	36	0,1/0,15/0,2/0,25/0,3/0,5/1/1,2/1,5/2
K1151.3747***	steel	47	37	0,1/0,15/0,2/0,25/0,3/0,5/1/1,2/1,5/2
K1151.4050***	steel	50	40	0,1/0,15/0,2/0,25/0,3/0,5/1/1,2/1,5/2
K1151.4252***	steel	52	42	0,1/0,15/0,2/0,25/0,3/0,5/1/1,2/1,5/2
K1151.4555***	steel	55	45	0,1/0,15/0,2/0,25/0,3/0,5/1/1,2/1,5/2
K1151.4860***	steel	60	48	0,1/0,15/0,2/0,25/0,3/0,5/1/1,2/1,5/2
K1151.5062***	steel	62	50	0,1/0,15/0,2/0,25/0,3/0,5/1/1,2/1,5/2



Clamping force intensifiers

Material:

Bearing housing steel.

Version:

Black oxidised.

Sample order:

K0584.06

Note:

As a rule, the clamping force intensifier is used together with tightening or clamping elements. The integrated axial needle roller thrust bearing unit can achieve ca. twice the clamping force by the same lever length.

Advantages:

The component surface is protected by the stationary lower ring.

The higher preload force causes a lower tendency for material relaxation in the thread.

Clamping levers, wing and star grips, knurled knobs or hexagonal and socket head screws etc. can be used as tightening or clamping elements.

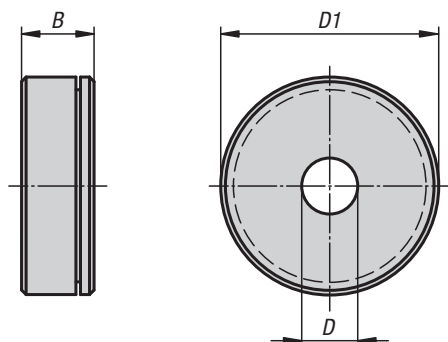

With constant torque

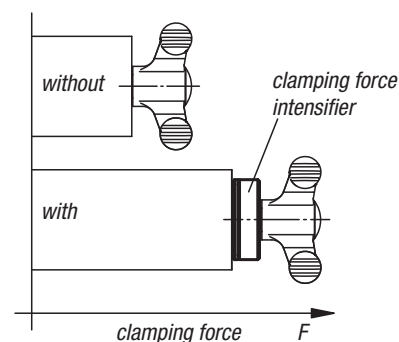

KIPP Clamping force intensifiers

Order No.	B	D	D1
K0584.06	8	6	24
K0584.08	8	8	25
K0584.10	8	10	30
K0584.12	8	12	35

K0730

C-washers

DIN 6372 enhanced

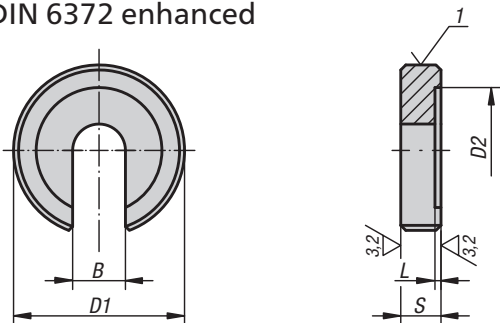

KIPP C-washers for fixtures DIN 6372 enhanced

Order No.	B	D1	D2	L	S
K0730.05	5,25	17	12	0,75	5
K0730.06	6,4	22	16	0,8	6
K0730.08	8,4	28	21	1	7
K0730.10	10,5	34	25	1,2	8
K0730.12	13	40	30	1,8	9
K0730.14	14,5	48	33	1,8	12
K0730.16	17	56	37	1,8	12
K0730.20	21	64	45	2	14
K0730.24	25	75	52	2	16
K0730.30	31	90	65	2	18
K0730.36	37	100	75	2,5	20



Material:
Carbon steel.

Version:
Tempered and black oxidised.

Sample order:
K0730.12

Drawing reference:
1) cross knurl

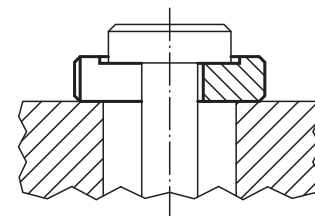

K0703

C-washers captive

DIN 6371

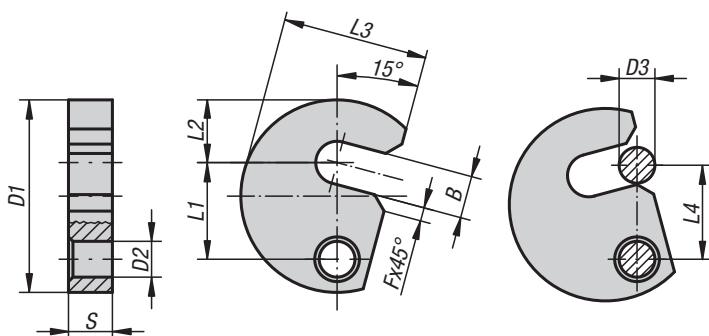

KIPP C-washers captive DIN 6371

Order No.	B	D1	D2	D3	F	L1	L2	L3	L4	S
K0703.06	7,5	38	9	6	3	19,6	11	29	19	9,8
K0703.08	9,5	43	9	8	3	21,6	14	32,5	21	9,8
K0703.10	11,5	48	9	10	3	23,6	17	36,5	23	9,8
K0703.12	13,5	61	11	12	3	29,6	22	45	29	11,8
K0703.14	15,5	65	11	14	3	31,6	23	49	31	11,8
K0703.16	17,5	68	11	16	3	33,6	25	50	33	11,8
K0703.20	21,5	74	11	20	4	36,6	28	55	36	11,8



Material:
Carbon steel 1.0760.

Version:
Nitrided and black oxidised.

Sample order:
K0703.12

Note:
K0703.14 is not standard. Suitable shoulder screws see K0704.

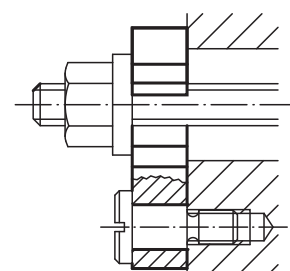

K0704

Shoulder screws with slotted flat head

DIN 923

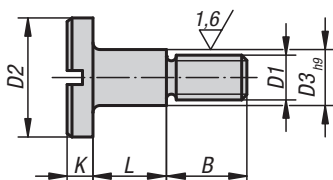
**Material:**

Steel.

Version:

Black oxidised, grade 5.8.

Sample order:

K0704.08

Note:

For use with captive C-washers K0703.

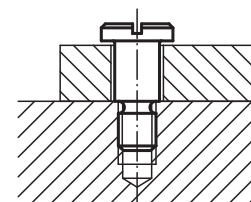
**KIPP Shoulder screws with slotted flat head DIN 923**

Order No.	D1	D2	D3	L	B	K
K0704.06	M6	13	8	10 +0,15/+0,07	9	3,1
K0704.08	M8	16	10	12 +0,2/+0,1	11	3,8
K0704.10	M10	20	13	16 +0,2/+0,1	13,5	4,6

Shoulder screws

similar to DIN ISO 7379

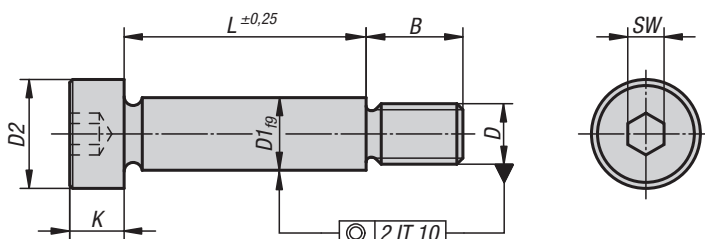
Material:

Steel or stainless steel (A 2)

Version:

Grade 12.9. Shaft OD ground and bright.
Bright stainless steel or black oxidised steel.

Sample order:

K0705.06X20 (include length L)

Note:

Hexagon socket head shoulder screws are precision construction elements for many applications. As they can simplify complicated constructions, they are frequently chosen as the most cost-effective solution. Shoulder screws provide the decisive rationalising effect required today.

KIPP Shoulder screws similar to DIN ISO 7379

Order No.	Main material	D1	D	D2	B	K	SW	L
K0705.04X	steel	4	M3	7	7	3	2	6/8/10/12/16/20
K0705.05X	steel	5	M4	9	8	4	2,5	8/10/16/20/30/40
K0705.06X	steel	6	M5	10	9,5	4,5	3	16/20/25/30/40/50/60
K0705.08X	steel	8	M6	13	11	5,5	4	16/20/25/30/40/50/60
K0705.10X	steel	10	M8	16	13	7	5	16/20/25/30/40/50/60/70/80
K0705.12X	steel	12	M10	18	16	9	6	16/20/25/30/40/50/60/70/80/90/100
K0705.16X	steel	16	M12	24	18	11	8	30/40/50/60/70/80/90/100/120
K0705.20X	steel	20	M16	30	22	14	10	30/40/50/60/70/80/90/100/120
K0705.104X	stainless steel	4	M3	7	7	3	2	6/8/10/16/20
K0705.105X	stainless steel	5	M4	9	8	4	2,5	8/10/16/20/30/40
K0705.106X	stainless steel	6	M5	10	9,5	4,5	3	16/20/25/30/40/50/60
K0705.108X	stainless steel	8	M6	13	11	5,5	4	16/20/25/30/40/50/60
K0705.110X	stainless steel	10	M8	16	13	7	5	16/20/25/30/40/50/60/70/80
K0705.112X	stainless steel	12	M10	18	16	9	6	16/20/25/30/40/50/60/70/80/90/100
K0705.116X	stainless steel	16	M12	24	18	11	8	30/40/50/60/70/80/90/100/120
K0705.120X	stainless steel	20	M16	30	22	14	10	30/40/50/60/70/80/90/100/120



Shoulder screws

with hexagon head, DIN 609

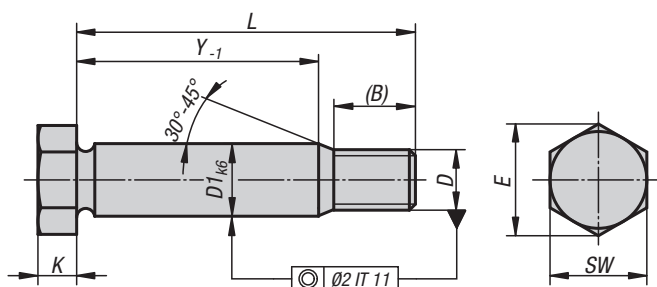
Material:

Steel.

Version:

Grade 8.8, black oxidised.
Shaft OD ground.

Sample order:

K0706.09X40 (include length L)

Note:

Shoulder screws are used if the screw connection is subjected to transverse forces or if workpieces must be positioned relative to each other.

KIPP Shoulder screws with hexagon head, DIN 609

Order No.	D1	D	(B) reference dimension	E	K	SW	Y	L
K0706.09X25	9	M8	14,5	14,38	5,3	13	8	25
K0706.09X30	9	M8	14,5	14,38	5,3	13	13	30
K0706.09X35	9	M8	14,5	14,38	5,3	13	18	35
K0706.09X40	9	M8	14,5	14,38	5,3	13	23	40
K0706.09X45	9	M8	14,5	14,38	5,3	13	28	45
K0706.09X50	9	M8	14,5	14,38	5,3	13	33	50
K0706.09X60	9	M8	16,5	14,38	5,3	13	41	60
K0706.11X30	11	M10	17,5	17,77	6,4	17	10	30
K0706.11X35	11	M10	17,5	17,77	6,4	17	15	35
K0706.11X40	11	M10	17,5	17,77	6,4	17	20	40
K0706.11X45	11	M10	17,5	17,77	6,4	17	25	45
K0706.11X50	11	M10	17,5	17,77	6,4	17	30	50
K0706.11X60	11	M10	19,5	17,77	6,4	17	38	60
K0706.11X70	11	M10	19,5	17,77	6,4	17	48	70
K0706.11X80	11	M10	19,5	17,77	6,4	17	58	80
K0706.11X90	11	M10	19,5	17,77	6,4	17	68	90
K0706.11X100	11	M10	19,5	17,77	6,4	17	78	100

Shoulder screws

with hexagon head, DIN 609



KIPP Shoulder screws with hexagon head, DIN 609

Order No.	D1	D	(B) reference dimension	E	K	SW	Y	L
K0706.13X35	13	M12	20,5	19,85	7,5	19	11,5	35
K0706.13X40	13	M12	20,5	19,85	7,5	19	16,5	40
K0706.13X45	13	M12	20,5	19,85	7,5	19	21,5	45
K0706.13X50	13	M12	20,5	19,85	7,5	19	26,5	50
K0706.13X60	13	M12	22,5	19,85	7,5	19	34,5	60
K0706.13X70	13	M12	22,5	19,85	7,5	19	44,5	70
K0706.13X80	13	M12	22,5	19,85	7,5	19	54,5	80
K0706.13X90	13	M12	22,5	19,85	7,5	19	64,5	90
K0706.13X100	13	M12	22,5	19,85	7,5	19	74,5	100
K0706.17X40	17	M16	25	26,17	10	24	11,5	40
K0706.17X45	17	M16	25	26,17	10	24	16,5	45
K0706.17X50	17	M16	25	26,17	10	24	21,5	50
K0706.17X60	17	M16	27	26,17	10	24	29,5	60
K0706.17X70	17	M16	27	26,17	10	24	39,5	70
K0706.17X80	17	M16	27	26,17	10	24	49,5	80
K0706.17X90	17	M16	27	26,17	10	24	59,5	90
K0706.17X100	17	M16	27	26,17	10	24	69,5	100
K0706.21X50	21	M20	28,5	32,95	12,5	30	17,5	50
K0706.21X60	21	M20	30,5	32,95	12,5	30	25,5	60
K0706.21X70	21	M20	30,5	32,95	12,5	30	35,5	70
K0706.21X80	21	M20	30,5	32,95	12,5	30	45,5	80
K0706.21X90	21	M20	30,5	32,95	12,5	30	55,5	90
K0706.21X100	21	M20	30,5	32,95	12,5	30	65,5	100
K0706.21X120	21	M20	30,5	32,95	12,5	30	85,5	120
K0706.25X60	25	M24	36,5	39,35	15	36	19	60
K0706.25X70	25	M24	36,5	39,35	15	36	29	70
K0706.25X80	25	M24	36,5	39,35	15	36	39	80
K0706.25X90	25	M24	36,5	39,35	15	36	49	90
K0706.25X100	25	M24	36,5	39,35	15	36	59	100
K0706.25X120	25	M24	36,5	39,35	15	36	79	120



Grub screws with flat point

hexagon socket DIN 913

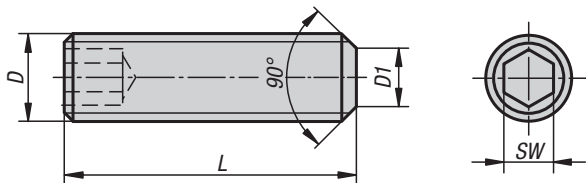

LONG-LOK

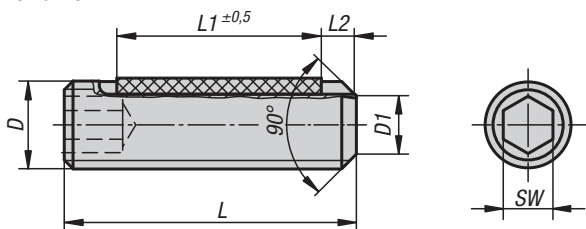
Material:

Steel or stainless steel (A 2).

LONG-LOK thread lock nylon.

Version:

Steel class 45 H, black.

Stainless steel A 2-70, bright.

Sample order:

K0707.110X20 (include length L)

Drawing reference:

L2 = approx. 2x thread pitch

KIPP Grub screws with flat point, hexagon socket DIN 913

Order No.	Main material	D	L	D1	SW
K0707.03X	Steel	M3	5/6/8/10/12/16/20	2	1,5
K0707.04X	Steel	M4	5/6/8/10/12/16/20/25	2,5	2
K0707.05X	Steel	M5	5/6/8/10/12/16/20/25/30	3,5	2,5
K0707.06X	Steel	M6	6/8/10/12/16/20/25/30/35/40/45/50/60	4	3
K0707.08X	Steel	M8	8/10/12/16/20/25/30/35/40/45/50/60/70/80	5,5	4
K0707.10X	Steel	M10	10/12/16/20/25/30/35/40/45/50/60/70/80/90/100	7	5
K0707.103X	Stainless steel	M3	5/6/8/10/12	2	1,5
K0707.104X	Stainless steel	M4	5/6/8/10/12/16/20	2,5	2
K0707.105X	Stainless steel	M5	5/6/8/10/12/16/20/25/30	3,5	2,5
K0707.106X	Stainless steel	M6	6/8/10/12/16/20/25/30/35/40	4	3
K0707.108X	Stainless steel	M8	8/10/12/16/20/25/30/35/40/45/50	5,5	4
K0707.110X	Stainless steel	M10	10/12/16/20/25/30/35/40/45/50	7	5

KIPP Grub screws with flat point, hexagon socket DIN 913, LONG-LOK secured

Order No.	Version	Main material	D	L	L1	D1	SW
K0707.203X	Long-Lok	Steel	M3	5/6/8/10/12	2/3/4/4/4	2	1,5
K0707.204X	Long-Lok	Steel	M4	5/6/8/10/12/16	2/2,5/3,5/5/5/5	2,5	2
K0707.205X	Long-Lok	Steel	M5	5/6/8/10/12/16	2/3/3,5/3,5/5/6	3,5	2,5
K0707.206X	Long-Lok	Steel	M6	6/8/10/12/16/20	2,5/3/3,5/5/7/7	4	3
K0707.208X	Long-Lok	Steel	M8	8/10/12/16/20	3/3,5/5/8/8	5,5	4
K0707.210X	Long-Lok	Steel	M10	10/12/16/20	5/5/9/9	7	5
K0707.303X	Long-Lok	Stainless steel	M3	5/6/8/10/12	2/3/4/4/4	2	1,5
K0707.304X	Long-Lok	Stainless steel	M4	5/6/8/10/12/16	2/2,5/3,5/5/5/5	2,5	2
K0707.305X	Long-Lok	Stainless steel	M5	5/6/8/10/12/16	2/3/3,5/3,5/5/6	3,5	2,5
K0707.306X	Long-Lok	Stainless steel	M6	6/8/10/12/16/20	2,5/3/3,5/5/7/7	4	3
K0707.308X	Long-Lok	Stainless steel	M8	8/10/12/16/20	3/3,5/5/8/8	5,5	4
K0707.310X	Long-Lok	Stainless steel	M10	10/12/16/20	5/5/9/9	7	5

Screws with countersunk head

hexagon socket DIN EN ISO 10642

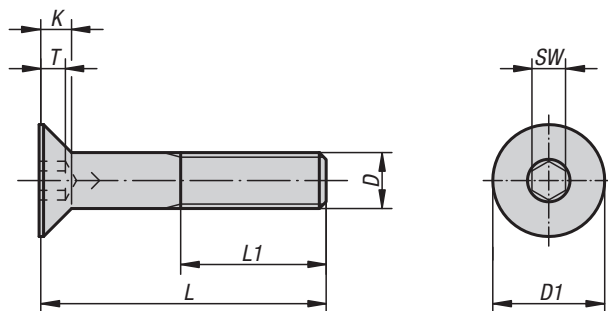
**Material:**

Steel or stainless steel (A 2)

Version:

Steel grade 8.8, black or galvanized.

Steel grade 10.9, black.

Stainless steel A 2-70, bright.

Sample order:

K0708.106X20 (include length L)

KIPP Screws with countersunk head, hexagon socket DIN 7991

Order No. steel Grade 8.8	Order No. steel Grade 10.9	Surface	D	L	L1 min.	K	T	D1	SW
K0708.04X	K0708.304X	-	M4	10/12/16/20/25	14	2,3	1,8	8	2,5
K0708.05X	K0708.305X	-	M5	10/12/16/20/25/30	16	2,8	2,3	10	3
K0708.06X	K0708.306X	-	M6	10/12/16/20/25/30/35/40/45/50/60	18	3,3	2,5	12	4
K0708.08X	K0708.308X	-	M8	16/20/25/30/35/40/45/50/60	22	4,4	3,5	16	5
K0708.10X	K0708.310X	-	M10	16/20/25/30/35/40/45/50/60/70	26	5,5	4,4	20	6
K0708.12X	K0708.312X	-	M12	20/25/30/35/40/45/50/60/70/80	30	6,5	4,6	24	8
K0708.16X	K0708.316X	-	M16	30/35/40/45/50/60/70/80	38	7,5	5,3	30	10
K0708.404X	-	Galvanized	M4	10/12/16/20/25	14	2,3	1,8	8	2,5
K0708.405X	-	Galvanized	M5	10/12/16/20/25/30	16	2,8	2,3	10	3
K0708.406X	-	Galvanized	M6	10/12/16/20/25/30/35/40/45/50/60	18	3,3	2,5	12	4
K0708.408X	-	Galvanized	M8	16/20/25/30/35/40/45/50/60	22	4,4	3,5	16	5
K0708.410X	-	Galvanized	M10	16/20/25/30/35/40/45/50/60/70	26	5,5	4,4	20	6
K0708.412X	-	Galvanized	M12	20/25/30/35/40/45/50/60/70/80	30	6,5	4,6	24	8
K0708.416X	-	Galvanized	M16	30/35/40/45/50/60/70/80	38	7,5	5,3	30	10

Order No.	Main material	D	L	L1 min.	K	T	D1	SW
K0708.104X	stainless steel	M4	10/12/16/20/25	14	2,3	1,8	8	2,5
K0708.105X	stainless steel	M5	10/12/16/20/25/30	16	2,8	2,3	10	3
K0708.106X	stainless steel	M6	10/12/16/20/25/30/35/40/45/50/60	18	3,3	2,5	12	4
K0708.108X	stainless steel	M8	16/20/25/30/35/40/45/50/60	22	4,4	3,5	16	5
K0708.110X	stainless steel	M10	16/20/25/30/35/40/45/50/60/70	26	5,5	4,4	20	6
K0708.112X	stainless steel	M12	20/25/30/35/40/45/50/60/70/80	30	6,5	4,6	24	8
K0708.116X	stainless steel	M16	30/35/40/45/50/60/70/80	38	7,5	5,3	30	10



Socket head screws

full thread, DIN 912 / DIN EN ISO 4762

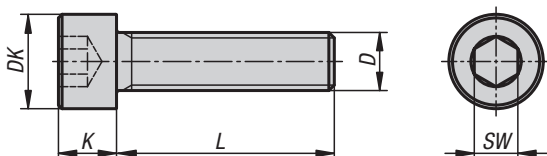

Material:

Steel.

Version:

Grade 8.8, black or galvanized.

Sample order:

K1159.05X40 (include length L)

KIPP Socket head screws full thread, DIN 912 / DIN EN ISO 4762

Order No.	Grade	Surface	D	L	DK	K	SW
K1159.05X	8.8	-	M5	40/50/60/80	8,5	5	4
K1159.06X	8.8	-	M6	40/50/60/70/90/100	10	6	5
K1159.08X	8.8	-	M8	50/60/70/80/90	13	8	6
K1159.10X	8.8	-	M10	50/60/70/80/90/100	16	10	8
K1159.12X	8.8	-	M12	80/90/100	18	12	10
K1159.405X	8.8	Galvanized	M5	40/70/80	8,5	5	4
K1159.406X	8.8	Galvanized	M6	40/50/60/70/80/90/100	10	6	5
K1159.408X	8.8	Galvanized	M8	50/60/70/80/90/100	13	8	6
K1159.410X	8.8	Galvanized	M10	50/60/70/80/90/100	16	10	8
K1159.412X	8.8	Galvanized	M12	70/80/90/100	18	12	10

Notes



A large grid area for taking notes, consisting of a fine grid of small squares. The grid is approximately 30 columns wide and 60 rows high, covering most of the page's content area.



Socket head screws

DIN 912 / DIN EN ISO 4762, steel or stainless steel

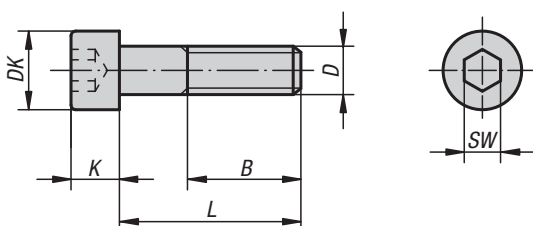
Material:

Steel or stainless steel (A 2)

Version:

Steel grade 8.8, black or galvanised.
Steel grade 10.9, black or galvanised.
Stainless steel A 2-70, bright.

Sample order:

K0869.08X40 (include length L)

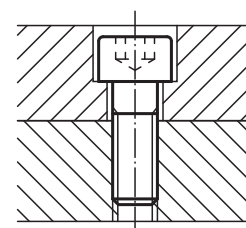

KIPP Socket head screws DIN 912 / EN ISO 4762, steel or stainless steel

Order No. Grade 8.8	Order No. Grade 8.8 Galvanized	D	L	B	DK	K	SW
K0869.04X	K0869.404X	M4	10/12/16/18/20/25	20	7	4	3
K0869.05X	K0869.405X	M5	10/12/16/18/20/25/30/40	22	8,5	5	4
K0869.06X	K0869.406X	M6	10/12/16/18/20/25/30/35/40/45/50/55/60	24	10	6	5
K0869.08X	K0869.408X	M8	16/18/20/25/30/35/40/45/50/60/70/80	28	13	8	6
K0869.10X	K0869.410X	M10	16/18/20/25/30/35/40/45/50/60/70/80/90/100	32	16	10	8
K0869.12X	K0869.412X	M12	20/25/30/35/40/45/50/60/70/80/90/100/110/120	36	18	12	10
K0869.14X	K0869.414X	M14	50/80/120	40	21	14	12
K0869.16X	K0869.416X	M16	30/35/40/45/50/60/70/80/90/100/110/120	44	24	16	14
K0869.20X	K0869.420X	M20	40/45/50/60/70/80/90/100/110/120	52	30	20	17

Socket head screws

DIN 912 / DIN EN ISO 4762, steel or stainless steel



Order No.	Grade	Surface	D	L	B	DK	K	SW
K0869.304X	10.9	-	M4	10/12/16/18/20/25	20	7	4	3
K0869.305X	10.9	-	M5	10/12/16/18/20/25/30/40	22	8,5	5	4
K0869.306X	10.9	-	M6	10/12/16/18/20/25/30/35/40/55/45/50/60	24	10	6	5
K0869.308X	10.9	-	M8	16/18/20/25/30/35/40/45/50/60/70/80	28	13	8	6
K0869.310X	10.9	-	M10	16/18/20/25/30/35/40/45/50/60/70/80/90/100	32	16	10	8
K0869.312X	10.9	-	M12	20/25/30/35/40/45/50/60/70/80/90/100/110/120	36	18	12	10
K0869.314X	10.9	-	M14	50/80/120	40	21	14	12
K0869.316X	10.9	-	M16	30/35/40/45/50/60/70/80/90/100/110/120	44	24	16	14
K0869.320X	10.9	-	M20	40/45/50/60/70/80/90/100/110/120	52	30	20	17
K0869.504X	10.9	Galvanized	M4	10/12/16/18/20/25	20	7	4	3
K0869.505X	10.9	Galvanized	M5	10/12/16/18/20/25/30/40	22	8,5	5	4
K0869.506X	10.9	Galvanized	M6	10/12/16/18/20/25/30/35/40/45/50/55/60	24	10	6	5
K0869.508X	10.9	Galvanized	M8	16/20/25/30/35/40/45/50/60/70/80	28	13	8	6
K0869.510X	10.9	Galvanized	M10	16/18/20/25/30/35/40/45/50/60/70/80/90/100	32	16	10	8
K0869.512X	10.9	Galvanized	M12	20/25/30/35/40/45/50/60/70/80/90/100/110/120	36	18	12	10
K0869.514X	10.9	Galvanized	M14	50/80/120	40	21	14	12
K0869.516X	10.9	Galvanized	M16	30/35/40/45/50/60/70/80/90/100/110/120	44	24	16	14
K0869.520X	10.9	Galvanized	M20	40/45/50/60/70/80/90/100/110/120	52	30	20	17

Order No.	Main material	D	L	B	DK	K	SW
K0869.104X	stainless steel	M4	10/12/16/18/20/25	20	7	4	3
K0869.105X	stainless steel	M5	10/12/16/18/20/25/30/40	22	8,5	5	4
K0869.106X	stainless steel	M6	10/12/16/18/20/25/30/35/40/45/50/60/55	24	10	6	5
K0869.108X	stainless steel	M8	16/18/20/25/30/35/40/45/50/60/70/80	28	13	8	6
K0869.110X	stainless steel	M10	18/16/20/25/30/35/40/45/50/60/70/80/90/100	32	16	10	8
K0869.112X	stainless steel	M12	20/25/30/35/40/45/50/60/70/80/90/100/110/120	36	18	12	10

Socket head screws

DIN 912/DIN EN ISO 4762



Material:

Steel.

Version:

Steel grade 12.9, black.

Sample order:

K0869.206X40 (include length L)

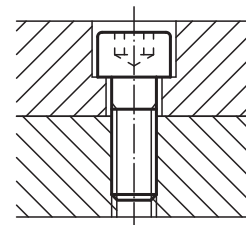
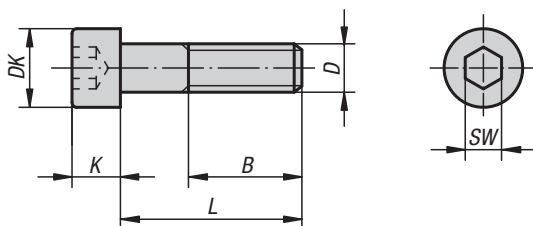

KIPP Socket head screws DIN 912/DIN EN ISO 4762

Order No.	Grade	D	L	B	DK	K	SW
K0869.206X	12.9	M6	18/20/25/30/35/40/45/50/55/60/65/70/80/90/100	24	10	6	5
K0869.208X	12.9	M8	20/25/30/35/40/45/50/55/60/65/70/80/90/100/120	28	13	8	6
K0869.210X	12.9	M10	30/35/40/45/50/55/60/65/70/75/80/90/100/110/120/130/140	32	16	10	8
K0869.212X	12.9	M12	30/35/40/45/50/55/60/65/70/75/80/90/100/110/120/130/140	36	18	12	10
K0869.216X	12.9	M16	35/40/45/50/55/60/65/70/75/80/90/100/110/120/130/140/150/160/170/180/200	44	24	16	14
K0869.218X	12.9	M18	35/40/45/50/55/60/65/70/75/80/90/100/110/120/130/140/150/160/170/180/200	48	27	18	14
K0869.220X	12.9	M20	40/45/50/55/60/65/70/75/80/90/100/110/120/130/140/150/160/170/180/200	52	30	20	17

Socket head screws

DIN 912 / EN ISO 4762, LONG-LOK secured

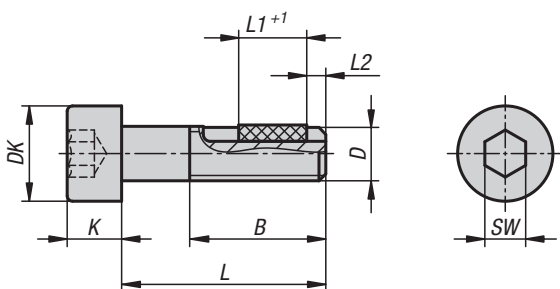

Material:

Steel or stainless steel (A 2).

LONG-LOK thread lock nylon.

Version:

Steel grade 8.8, black.

Stainless steel A 2-70, bright.

Sample order:

K0869.806X20 (include length L)

Drawing reference:

L2 = approx. 2x thread pitch

KIPP Socket head screws DIN 912 / DIN EN ISO 4762, LONG-LOK secured

Order No. steel	Order No. stainless steel	D	L	B	DK	K	L1	SW	Tightening torque approx. Nm	Loosening torque approx. Nm
K0869.804X	K0869.904X	M4	10/12/16/20/25	-	7	4	5/5/6/7/7	3	0,15	0,22
K0869.805X	K0869.905X	M5	10/12/16/20/25/30/40	-22	8,5	5	5/6/7/7/8/8/8	4	0,25	0,1
K0869.806X	K0869.906X	M6	10/12/16/20/25/30/35/40/45/50	-24	10	6	5/6/7/7/8/8/8/8/8	5	0,45	0,25
K0869.808X	K0869.908X	M8	16/20/25/30/35/40/45	-28	13	8	7/8/8/8/10/10/10	6	0,8	0,4
K0869.810X	K0869.910X	M10	25/30/40/50	-32	16	10	10/10/12/12	8	1,7	0,9
K0869.812X	K0869.912X	M12	30/40/50	-	18	12	10/12/12	10	1,8	0,9



Socket head screws with low head

DIN 6912

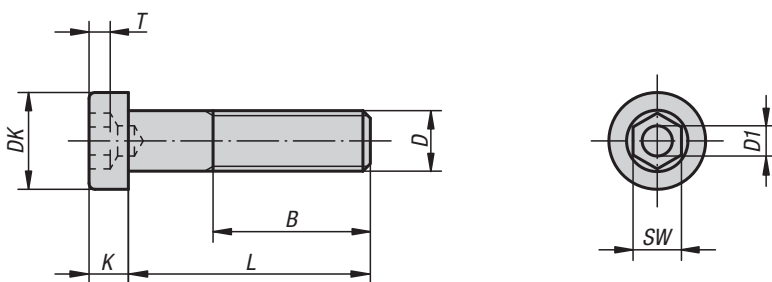
**Material:**

Steel or stainless steel (A 2)

Version:

Steel grade 8.8, black or galvanised.

Steel grade 10.9, black.

Stainless steel A 2-70, bright.

Sample order:

K1160.110X20 (include length L)

KIPP Socket head screws with low head DIN 6912, stainless steel

Order No.	Main material	D	DK	K	D1	SW	T
K1160.104X	stainless steel	M4	7	2,8	2	3	1,48
K1160.105X	stainless steel	M5	8,5	3,5	2,5	4	1,88
K1160.106X	stainless steel	M6	10	4	3	5	2,38
K1160.108X	stainless steel	M8	13	5	4	6	2,88
K1160.110X	stainless steel	M10	16	6,5	5	8	3,35
K1160.112X	stainless steel	M12	18	7,5	6	10	3,85

Order No.	Main material	D	L	B
K1160.104X	stainless steel	M4	10/12/16/20/25	6,5/8,5/12,5/14/14
K1160.105X	stainless steel	M5	10/12/16/20/25/30	5,8/7,8/11,8/15,8/16/16
K1160.106X	stainless steel	M6	10/12/16/20/25/30/35/40/45/50/60	4,5/6,5/10,5/14,5/19,5/18/18/18/18/18
K1160.108X	stainless steel	M8	10/12/16/20/25/30/35/40/45/50/60/70	6/5/9/22/22/22/22/22/22/22/22
K1160.110X	stainless steel	M10	16/20/25/30/35/40/45/50/60/70	8/12/17/22/27/26/26/26/26/26
K1160.112X	stainless steel	M12	20/25/30/35/40/45/50/60/70	10,5/15,5/30/25,5/30,5/30/30/30/30

Socket head screws with low head

DIN 6912



KIPP Socket head screws with low head DIN 6912, steel

Order No. Grade 8.8	Order No. Grade 8.8 Galvanized	Order No. Grade 10.9	D	DK	K	D1	SW	T
K1160.04X	K1160.404X	-	M4	7	2,8	2	3	1,48
K1160.05X	K1160.405X	-	M5	8,5	3,5	2,5	4	1,88
K1160.06X	K1160.406X	K1160.306X	M6	10	4	3	5	2,38
K1160.08X	K1160.408X	K1160.308X	M8	13	5	4	6	2,88
K1160.10X	K1160.410X	K1160.310X	M10	16	6,5	5	8	3,35
K1160.12X	K1160.412X	K1160.312X	M12	18	7,5	6	10	3,85
K1160.16X	K1160.416X	K1160.316X	M16	24	10	8	14	5,35
K1160.20X	K1160.420X	K1160.320X	M20	30	12	10	17	6,32

Order No.	Main material	Surface	Grade	D	L	B
K1160.04X	steel	-	8.8	M4	10/12/16/20/25	6,5/8,5/12,5/14/14
K1160.05X	steel	-	8.8	M5	10/12/16/20/25/30	5,8/7,8/11,8/15,8/16/16
K1160.06X	steel	-	8.8	M6	10/12/16/20/25/30/35/40/45/50/60	4,5/6,5/10,5/14,5/19,5/18/18/18/18/18
K1160.08X	steel	-	8.8	M8	10/12/16/20/25/30/35/40/45/50/60/70/80	4/5/9/13/22/22/22/22/22/22/22/22/22
K1160.10X	steel	-	8.8	M10	20/25/30/35/40/45/50/60/70/80/90/100	12/17/22/27/26/26/26/26/26/26/26/26
K1160.12X	steel	-	8.8	M12	20/25/30/35/40/45/50/60/70/80/90/100/110/120	10,5/15,5/20,5/25,5/30,5/30/30/30/30/30/30/30/30
K1160.16X	steel	-	8.8	M16	30/35/40/45/50/60/70/80/90/100/110/120	19/24/38/38/38/38/38/38/38/38/38
K1160.20X	steel	-	8.8	M20	40/45/50/60/70/80/90/100/110/120	26/26/36/46/46/46/46/46/46/46
K1160.404X	steel	Galvanized	8.8	M4	10/12/16/20/25	6,5/8,5/12,5/14/14
K1160.405X	steel	Galvanized	8.8	M5	10/12/16/20/25/30	5,8/7,8/11,8/15,8/16/16
K1160.406X	steel	Galvanized	8.8	M6	10/12/16/20/25/30/35/40/45/50/60	4,5/6,5/10,5/14,5/19,5/18/18/18/18/18
K1160.408X	steel	Galvanized	8.8	M8	10/12/16/20/25/30/35/40/45/50/60/70/80	4/5/9/13/22/22/22/22/22/22/22/22/22
K1160.410X	steel	Galvanized	8.8	M10	20/25/30/35/40/45/50/60/70/80/90/100	12/17/22/27/26/26/26/26/26/26/26/26
K1160.412X	steel	Galvanized	8.8	M12	20/25/30/35/40/45/50/60/70/80/90/100/110/120	10,5/15,5/20,5/25,5/30,5/30/30/30/30/30/30/30/30
K1160.416X	steel	Galvanized	8.8	M16	30/35/40/45/50/60/70/80/90/100/110/120	19/24/38/38/38/38/38/38/38/38/38
K1160.420X	steel	Galvanized	8.8	M20	40/45/50/60/70/80/90/100/110/120	26/26/36/46/46/46/46/46/46/46
K1160.306X	steel	-	10.9	M6	10/12/16/20/25/30/35/40	4,5/6,5/10,5/14,5/19,5/18/18/18
K1160.308X	steel	-	10.9	M8	16/20/25/30/35/40/45/50/60	9/13/22/22/22/22/22/22/22
K1160.310X	steel	-	10.9	M10	20/25/30/35/40/45/50/60	12/17/22/27/26/26/26/26
K1160.312X	steel	-	10.9	M12	25/30/35/40/45/50/60	15,5/20,5/25,5/30,5/30/30/30
K1160.316X	steel	-	10.9	M16	30/35/40/45/50/60/70/80	19/24/38/38/38/38/38
K1160.320X	steel	-	10.9	M20	40/50/60/70	26/36/46/46



Parallel keys

DIN 6885 A

**Material:**

Steel 1.1192 or stainless steel 1.4571

Version:

Bright.

Sample order:

K0696.04X12 (include length L)

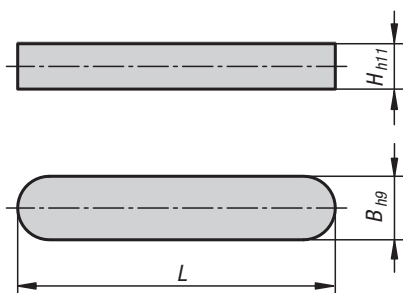

Application example:

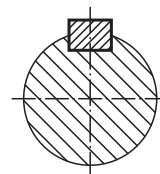

KIPP Parallel keys DIN 6885 A

Order No.	Main material	B	H	L = length
K0696.03X	steel	3	3	8/10/12/14/16/18/20/22/25/28
K0696.04X	steel	4	4	8/10/12/14/16/18/20/22/25/28
K0696.05X	steel	5	5	12/14/16/18/20/22/25/28/32/36/40
K0696.06X	steel	6	6	12/14/16/18/20/22/25/28/32/36/40/45
K0696.08X	steel	8	7	14/16/18/20/22/25/28/32/36/40/45/50/70
K0696.10X	steel	10	8	22/25/28/32/36/40/45/50/56/70/80
K0696.12X	steel	12	8	25/28/32/36/40/45/50/56/70/80
K0696.14X	steel	14	9	25/28/32/36/40/45/50/56/70/80
K0696.16X	steel	16	10	50/56/63/70/80/90/100
K0696.103X	stainless steel	3	3	10/12/16/20
K0696.104X	stainless steel	4	4	10/12/14/16/18/20/22
K0696.105X	stainless steel	5	5	12/14/16/18/20/22/25/28/36/40
K0696.106X	stainless steel	6	6	12/14/16/18/20/22/25/28/32/36/40
K0696.108X	stainless steel	8	7	16/18/20/22/25/28/32/36/40/45/50/70
K0696.110X	stainless steel	10	8	22/25/28/32/36/40/45/50/56/70/80
K0696.112X	stainless steel	12	8	28/32/36/40/45/50/56/70/80
K0696.114X	stainless steel	14	9	32/40/45/50/56/80/70
K0696.116X	stainless steel	16	10	50/63/70/80/90/100

Nuts for T-slots

DIN 508 enhanced

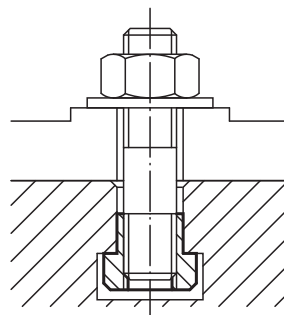
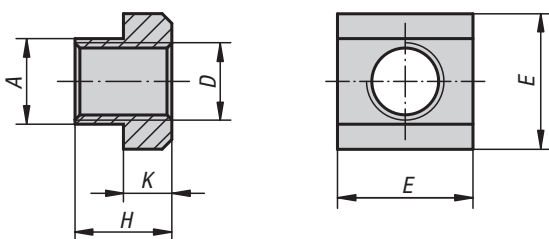
**Material:**

Carbon steel grade 10, EN AW-7075 or stainless steel 1.4305.

Version:Steel black.
Aluminium and stainless steel bright.**Sample order:**

K0377.20

Note:

Nuts for T-slots in aluminium have threaded steel inserts.

KIPP Nuts for T-slots to DIN 508 enhanced

Order No. Carbon steel	Order No. Aluminium	Order No. Stainless steel	Nominal slot size	D	A	E	H	K
K0377.05	K0377.204	-	6	M5/M4	5,6	10	8	4
K0377.06	K0377.206	K0377.806	8	M6	7,6	13	10	6
K0377.061	K0377.2061	-	10	M6	9,6	15	12	6
K0377.08	-	K0377.808	10	M8	9,6	15	12	6
K0377.081	K0377.208	-	12	M8	11,5	18	14	7
K0377.10	-	K0377.810	12	M10	11,5	18	14	7
K0377.082	-	-	14	M8	13,5	22	16	8
K0377.101	K0377.210	-	14	M10	13,5	22	16	8
K0377.12	-	K0377.812	14	M12	13,5	22	16	8
K0377.121	-	-	16	M12	15,6	25	18	9
K0377.14	-	K0377.814	16	M14	15,6	25	18	9
K0377.122	-	-	18	M12	17,5	28	20	10
K0377.141	-	-	18	M14	17,5	28	20	10
K0377.16	-	K0377.816	18	M16	17,5	28	20	10
K0377.123	-	-	20	M12	19,6	32	24	12
K0377.161	-	-	20	M16	19,6	32	24	12
K0377.18	-	-	20	M18	19,6	32	24	12
K0377.124	K0377.216	-	22	M12/M16	21,6	35	28	14
K0377.181	-	-	22	M18	21,6	35	28	14
K0377.20	-	-	22	M20	21,6	35	28	14
K0377.163	-	-	24	M16	23,6	40	32	16
K0377.201	-	-	24	M20	23,6	40	32	16
K0377.22	-	-	24	M22	23,6	40	32	16
K0377.164	-	-	28	M16	27,6	44	36	18
K0377.202	-	-	28	M20	27,6	44	36	18
K0377.24	-	-	28	M24	27,6	44	36	18
K0377.27	-	-	32	M27	31,5	50	40	20
K0377.241	-	-	36	M24	35,5	54	44	22
K0377.30	-	-	36	M30	35,5	54	44	22
K0377.36	-	-	42	M36	41,5	65	52	26



Nuts for T-slots

blanks

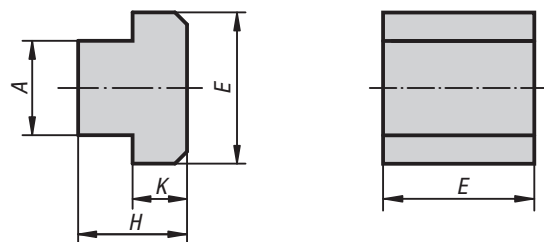
**Material:**

Carbon steel or stainless steel 1.4305.

Sample order:

K0378.16

Note:

These blank nuts are used to make nuts for T-slots with all sorts of thread sizes cost-effectively.

KIPP Nuts for T-slots, blanks

Order No. Carbon steel	Order No. Stainless steel	Nominal slot size	A	E	H	K
K0378.06	-	6	5,6	10	8	4
K0378.08	K0378.808	8	7,6	13	10	6
K0378.10	K0378.810	10	9,6	15	12	6
K0378.12	K0378.812	12	11,5	18	14	7
K0378.14	K0378.814	14	13,5	22	16	8
K0378.16	-	16	15,6	25	18	9
K0378.18	-	18	17,5	28	20	10
K0378.20	-	20	19,6	32	24	12
K0378.22	-	22	21,6	35	28	14
K0378.24	-	24	23,6	40	32	16
K0378.28	-	28	27,6	44	36	18
K0378.36	-	36	35,5	54	44	22
K0378.42	-	42	41,6	65	52	26

Nuts for T-slots

rhombic form

**Material:**

Carbon steel.

Version:

Tempered to 8 and black oxidised.

Sample order:

K0379.114

Note:

The benefit of rhombic nuts for T-slots is that they can be fitted in the slot from the top. They are particularly useful for long T-slots, or when the configuration on the machine table does not permit clamping screws or nuts for T-slots to be inserted from the side.

Application:

Insert from above then twist in the slot until it stops.

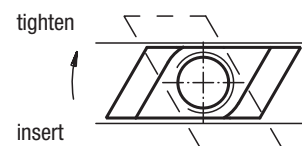
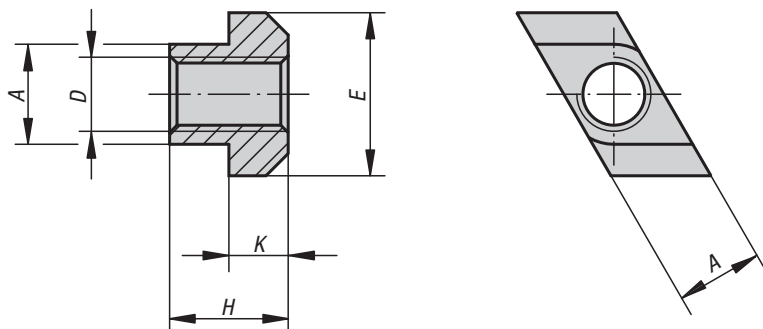

KIPP Nuts for T-slots, rhombic form

Order No.	Nominal slot size	D	A	E	H	K
K0379.105	6	M5	5,6	10	8	4
K0379.106	8	M6	7,6	13	10	6
K0379.108	10	M8	9,7	15	12	6
K0379.110	12	M10	11,7	18	14	7
K0379.210	14	M10	13,5	22	16	8
K0379.310	18	M10	17,5	28	20	10
K0379.112	14	M12	13,7	22	16	8
K0379.114	16	M14	15,7	25	18	9
K0379.116	18	M16	17,7	28	20	10
K0379.216	20	M16	19,7	32	24	12
K0379.316	22	M16	21,5	35	28	14
K0379.416	28	M16	27,5	44	36	18
K0379.118	20	M18	19,7	32	24	12
K0379.120	22	M20	21,7	35	28	14
K0379.124	28	M24	27,7	44	36	18
K0379.130	36	M30	35,6	54	44	22
K0379.136	42	M36	41,5	65	52	26



K0396

Eye bolts

DIN 444, Form B



Material:
Steel, grade 8.8 or stainless steel.

Version:
Steel black oxidised.
Stainless steel bright.

Sample order:
K0396.12100

Note:
Suitable hinge pin, see K0007.

Drawing reference:
U = max. 2 P (incomplete thread)
X1 = to DIN 76 part 1

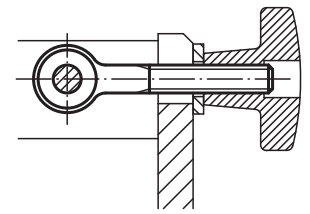
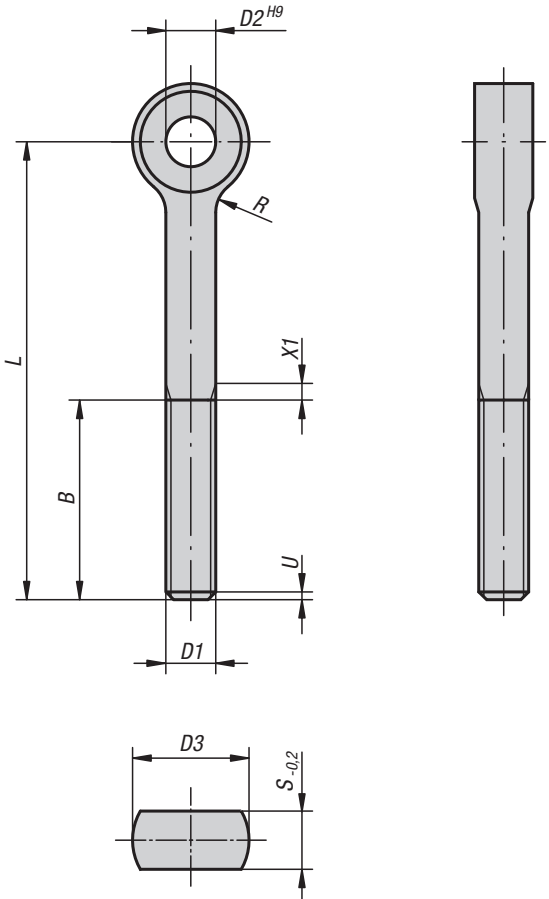

KIPP Eye bolts DIN 444

Order No. Steel	Order No. Stainless steel	D1	L	D2	D3	B	S	R
K0396.0550	K0396.10550	M5	50	5	12	16	6	2,5
K0396.0575	-	M5	75	5	12	16	6	2,5
K0396.0650	K0396.10650	M6	50	6	14	18	7	4
K0396.0675	K0396.10675	M6	75	6	14	18	7	4
K0396.0850	K0396.10850	M8	50	8	18	22	9	4
K0396.0875	K0396.10875	M8	75	8	18	22	9	4
K0396.1075	K0396.11075	M10	75	10	20	26	12	4
K0396.10100	K0396.110100	M10	100	10	20	26	12	4
K0396.1275	K0396.11275	M12	75	12	25	30	14	6
K0396.12100	K0396.112100	M12	100	12	25	30	14	6
K0396.12120	K0396.112120	M12	120	12	25	30	14	6
K0396.12130	K0396.112130	M12	130	12	25	36	14	6
K0396.1475	K0396.11475	M14	75	14	28	36	16	6
K0396.14130	K0396.114130	M14	130	14	28	36	16	6
K0396.16130	K0396.116130	M16	130	16	32	44	17	6
K0396.20140	K0396.120140	M20	140	18	40	52	22	6

Installing and removing threaded inserts

Fitting instructions

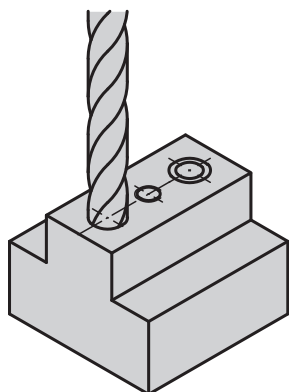

1.*
Rebore the old thread and countersink it (82° – 100°).

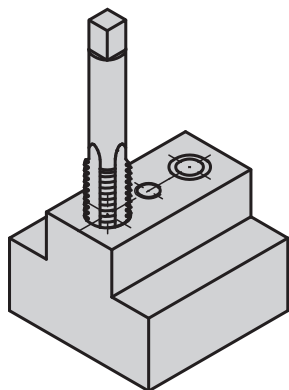

2.*
Tap thread with a standard screw tap.

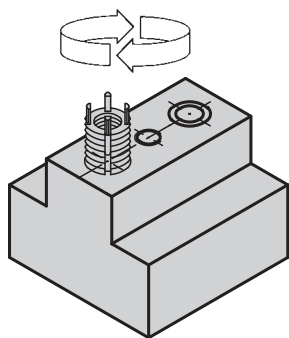

3.
Screw in the insert to just below the surface (0.3 – 0.7 mm).

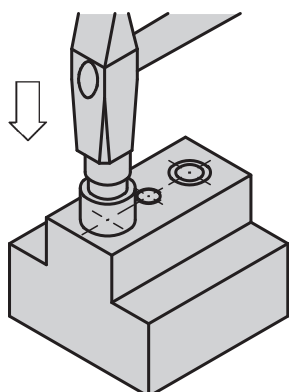

4.
Drive in the locking pins by striking the assembly tool lightly with a hammer.

* For steps 1 and 2 see table under installation of threaded inserts.

Removal instructions

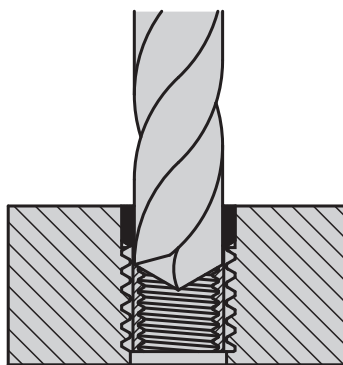

1.*
Rebore the material between the locking pins and the internal thread to the specified depth.

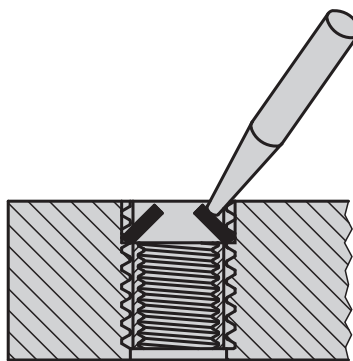

2.
Bend the locking pins inwards and break them off.

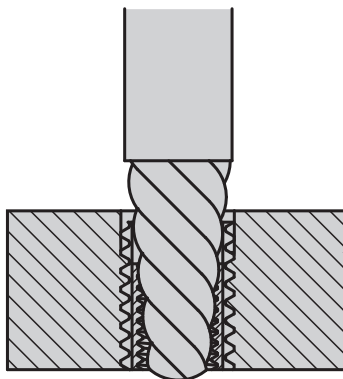

3.
Remove the old insert with a screw extractor.

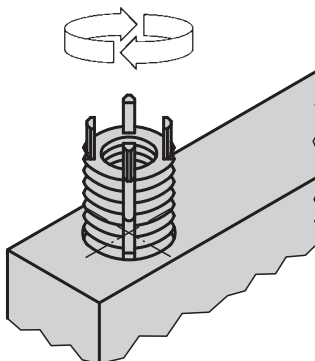

4.
Install a new threaded insert in the original threaded hole.

* For step 1 see tables under "removal drilling depth"

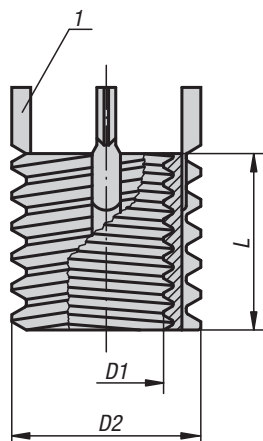
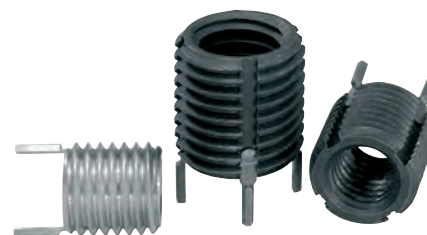

Threaded inserts

Material:

Threaded insert in steel or stainless steel.

Version:

Passivated.

Sample order:

Threaded Insert K0398.12

Assembly tool K0398.812

Note:

Threaded inserts allow threaded holes which have been damaged, torn out or jammed to be used again or to be repaired. This makes it possible to recover scrap and rejects of expensive products.

Threaded inserts are suitable for use in various materials, including light metals and casting. Inserts with internal threads larger than M6 are supplied with four locking pins instead of two. Permissible deviations: The medium tolerance class applies to the threads listed, i.e. 6H for nut threads and 6g for bolt threads. Other dimensions ± 0.25 mm.

Technical information see operating instructions for threaded inserts.

Advantages:

- Quick and easy installation.
- The insert is fixed with pins in order to prevent torsion due to twisting or vibrations.
- No other special tools are required besides the assembly tool.

Drawing reference:

1) locking pin

KIPP Threaded inserts and assembly tools

Order No. Steel	Order No. Stainless steel	D1 Internal thread	D2 External thread	L Length	Core drill \emptyset	Counter- sink \emptyset +0.25	Tap size	Min. thread depth	Removal drill \emptyset	Removal drilling depth	Order No. assembly tools
K0398.05	K0398.105	M5	M8	8	6,9	8,3	M8	9,5	5,5	4	K0398.805
K0398.06	K0398.106	M6	M10x1,25	10	8,8	10,3	M10x1,25	11,5	7,5	4,8	K0398.806
K0398.08	K0398.108	M8	M12x1,25	12	10,8	12,3	M12x1,25	13,5	9,5	4,8	K0398.808
K0398.08X1	K0398.108X1	M8x1	M12x1,25	12	10,8	12,3	M12x1,25	13,5	9,5	4,8	K0398.808
K0398.10	K0398.110	M10	M14x1,5	14	12,8	14,3	M14x1,5	15,5	11,5	4,8	K0398.810
K0398.10X125	K0398.110X125	M10x1,25	M14x1,5	14	12,8	14,3	M14x1,5	15,5	11,5	4,8	K0398.810
K0398.12	K0398.112	M12	M16x1,5	16	14,8	16,3	M16x1,5	17,5	13,5	4,8	K0398.812
K0398.12X125	K0398.112X125	M12x1,25	M16x1,5	16	14,8	16,3	M16x1,5	17,5	13,5	4,8	K0398.812

Threaded inserts reinforced

Material:

Threaded insert in steel or stainless steel.

Version:

Passivated.

Sample order:

Reinforced threaded insert K0399.12

Assembly tool K0399.812

Note:

Reinforced threaded inserts allow threaded holes which have been damaged, torn out or jammed to be used again or to be repaired. This makes it possible to recover scrap and rejects of expensive products.

Reinforced threaded inserts are suitable for use in various materials, including light metals and casting.

Inserts with internal threads larger than M6 are supplied with four locking pins instead of two.

Permissible deviations:

The medium tolerance class applies to the threads listed, i.e. 6H for nut threads and 6g for bolt threads. Other dimensions ± 0.25 mm.

With reinforced threaded inserts we also offer a version with a stronger cross-section for use in applications with greater stress.

Technical information see operating instructions for threaded inserts.

Advantages:

- Quick and easy installation.
- The insert is fixed with pins in order to prevent torsion due to twisting or vibrations.
- No other special tools are required besides the assembly tool.

Drawing reference:

1) locking pin

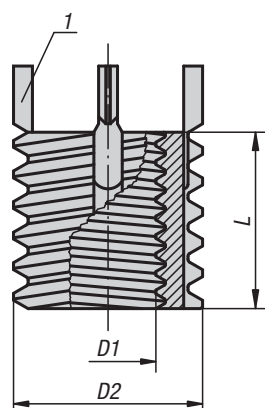

KIPP Threaded inserts reinforced and assembly tools

Order No. Steel	Order No. Stainless steel	D1 Internal thread	D2 External thread	L Length	Core drill \emptyset	Counter-sink \emptyset +0.25	Tap size	Min. thread depth	Removal drill \emptyset	Removal drilling depth	Order No. assembly tools
K0399.04	K0399.104	M4	M8	8	6,9	8,3	M8	9,5	5,5	4	K0399.804
K0399.05	K0399.105	M5	M10x1,25	10	8,8	10,3	M10x1,25	12,5	7,5	4,8	K0399.805
K0399.06	K0399.106	M6	M12x1,25	12	10,8	12,3	M12x1,25	14,5	9,5	4,8	K0399.806
K0399.08	K0399.108	M8	M14x1,5	14	12,8	14,3	M14x1,5	16,5	11,5	4,8	K0399.808
K0399.08X1	K0399.108X1	M8x1	M14x1,5	14	12,8	14,3	M14x1,5	16,5	11,5	4,8	K0399.808
K0399.10	K0399.110	M10	M16x1,5	16	14,8	16,3	M16x1,5	18,5	13,5	4,8	K0399.810
K0399.10X125	K0399.110X125	M10x1,25	M16x1,5	16	14,8	16,3	M16x1,5	18,5	13,5	4,8	K0399.810
K0399.12	K0399.112	M12	M18x1,5	18	16,8	18,3	M18x1,5	20,5	15,5	4,8	K0399.812
K0399.12X125	K0399.112X125	M12x1,25	M18x1,5	18	16,8	18,3	M18x1,5	20,5	15,5	4,8	K0399.812
K0399.14	K0399.114	M14	M20x1,5	20	18,8	20,3	M20x1,5	22,5	17,5	4,8	K0399.814
K0399.14X15	K0399.114X15	M14x1,5	M20x1,5	20	18,8	20,3	M20x1,5	22,5	17,5	4,8	K0399.814
K0399.16	K0399.116	M16	M22x1,5	22	20,7	22,3	M22x1,5	24,5	17,8	6,4	K0399.816
K0399.16X15	K0399.116X15	M16x1,5	M22x1,5	22	20,7	22,3	M22x1,5	24,5	17,8	6,4	K0399.816
K0399.18X15	K0399.118X15	M18x1,5	M24x1,5	24	22,5	24,3	M24x1,5	26,5	19,8	6,4	K0399.818
K0399.20	K0399.120	M20	M30x2	30	28	30,3	M30x2	34,5	25,8	6,4	K0399.820
K0399.20X15	K0399.120X15	M20x1,5	M30x2	30	28	30,3	M30x2	34,5	25,8	6,4	K0399.820
K0399.22X15	K0399.122X15	M22x1,5	M32x2	32	30	32,3	M32x2	36,5	27,8	6,4	K0399.822
K0399.24	K0399.124	M24	M33x2	33	31	33,3	M33x2	37,5	28,8	6,4	K0399.824
K0399.24X2	K0399.124X2	M24x2	M33x2	33	31	33,3	M33x2	37,5	28,8	6,4	K0399.824

Threaded inserts solid body

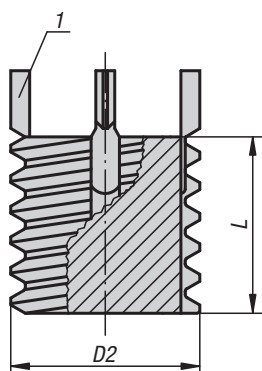
**Material:**

Threaded insert in steel.

Version:

Passivated.

Sample order:

Solid body threaded insert K0400.10X125

Assembly tool K0400.810

Note:

Solid body threaded inserts allow threaded holes which have been damaged, torn out or jammed to be used again or to be repaired. This makes it possible to recover scrap and rejects of expensive products.

Solid body threaded inserts are suitable for use in various materials, including light metals and castings.

Permissible deviations:

The medium tolerance class applies to the threads listed, i.e. 6g for bolt threads.

Other dimensions ± 0.25 mm.

Solid body threaded inserts are used where threaded holes that have been drilled too large or drill hole spacings that have not been observed in workpieces need to be redone.

Technical information see operating instructions for threaded inserts.

Advantages:

- Quick and easy installation.
- The insert is fixed with pins in order to prevent torsion due to twisting or vibrations.
- No other special tools are required besides the assembly tool.

Drawing reference:

1) locking pin

KIPP Threaded inserts solid body and assembly tools

Order No.	D2 External thread	L Length	Core drill \emptyset	Counter- sink \emptyset +0.25	Tap size	Min. thread depth	Removal drill \emptyset	Removal drilling depth	Order No. assembly tools
K0400.08	M8	8	6,9	8,3	M8	9,5	5,5	4	K0400.808
K0400.10X125	M10x1,25	10	8,8	10,3	M10x1,25	12,5	7,5	4,8	K0400.810
K0400.12X125	M12x1,25	12	10,8	12,3	M12x1,25	14,5	9,5	4,8	K0400.812
K0400.14X15	M14x1,5	14	12,8	14,3	M14x1,5	16,5	11,5	4,8	K0400.814
K0400.16X15	M16x1,5	16	14,8	16,3	M16x1,5	18,5	13,5	4,8	K0400.816
K0400.18X15	M18x1,5	18	16,8	18,3	M18x1,5	20,5	15,5	4,8	K0400.818
K0400.20X15	M20x1,5	20	18,8	20,3	M20x1,5	22,5	17,5	4,8	K0400.820
K0400.22X15	M22x1,5	22	20,7	22,3	M22x1,5	24,5	17,8	6,4	K0400.822
K0400.24X15	M24x1,5	24	22,5	24,3	M24x1,5	26,5	19,8	6,4	K0400.824
K0400.30X2	M30x2	30	28	30,3	M30x2	34,5	25,8	6,4	K0400.830

Threaded inserts

with internal thread, self-locking



Material:

Threaded insert in stainless steel.

Version:

Passivated.

Sample order:

Threaded Insert K0401.112

Assembly tool K0398.812

Note:

Threaded inserts allow threaded holes which have been damaged, torn out or jammed to be used again or to be repaired. This makes it possible to recover scrap and rejects of expensive products.

Threaded inserts are suitable for use in various materials, including light metals and casting. Inserts with internal threads larger than M6 are supplied with four locking pins instead of two.

Permissible deviations:

the medium tolerance class applies to the threads listed, i.e. 6H for nut threads and 6g for bolt threads. Other dimensions ± 0.25 mm.

Technical information see operating instructions for threaded inserts.

Advantages:

- Quick and easy installation.
- The insert is fixed with pins in order to prevent torsion due to twisting or vibrations.
- No other special tools are required besides the assembly tool.

Drawing reference:

- 1) locking pin
- 2) self-locking part of internal thread

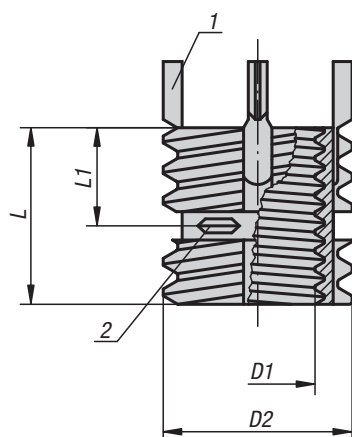

KIPP Threaded inserts with internal thread, self-locking and assembly tools

Order No.	D1 Internal thread	D2 External thread	L1 Length	L Length	Core drill \emptyset	Counter- sink \emptyset +0.25	Tap size	Min. thread depth	Removal drill \emptyset	Removal drilling depth	Order No. assembly tools
K0401.105	M5	M8	4	8	6,9	8,3	M8	9,5	5,5	4	K0398.805
K0401.106	M6	M10x1,25	5	10	8,8	10,3	M10x1,25	11,5	7,5	4,8	K0398.806
K0401.108	M8	M12x1,25	6	12	10,8	12,3	M12x1,25	13,5	9,5	4,8	K0398.808
K0401.110	M10	M14x1,5	7	14	12,8	14,3	M14x1,5	15,5	11,5	4,8	K0398.810
K0401.112	M12	M16x1,5	8	16	14,8	16,3	M16x1,5	17,5	13,5	4,8	K0398.812



Threaded inserts reinforced

internal thread, self-locking



Material:

Threaded insert in stainless steel.

Version:

Passivated.

Sample order:

Reinforced threaded insert K0402.110

Assembly tool K0399.812

Note:

Reinforced threaded inserts allow threaded holes which have been damaged, torn out or jammed to be used again or to be repaired. This makes it possible to recover scrap and rejects of expensive products. Reinforced threaded inserts are suitable for use in various materials, including light metals and casting. Inserts with internal threads larger than M6 are supplied with four locking pins instead of two.

Permissible deviations:

The medium tolerance class applies to the threads listed, i.e. 6H for nut threads and 6g for bolt threads. Other dimensions ± 0.25 mm.

Technical information see operating instructions for threaded inserts.

Advantages:

- Quick and easy installation.
- The insert is fixed with pins in order to prevent torsion due to twisting or vibrations.
- No other special tools are required besides the assembly tool.

Drawing reference:

- 1) locking pin
- 2) self-locking part of internal thread

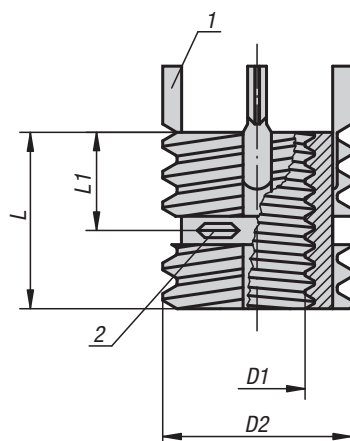

KIPP Threaded inserts reinforced with internal thread, self-locking and assembly tools

Order No.	D1 Internal thread	D2 External thread	L1 Length	L Length	Core drill \emptyset	Counter- sink \emptyset +0.25	Tap size	Min. thread depth	Removal drill \emptyset	Removal drilling depth	Order No. assembly tools
K0402.104	M4	M8	4	8	6,9	8,3	M8	9,5	5,5	4	K0399.804
K0402.105	M5	M10x1,25	5	10	8,8	10,3	M10x1,25	12,5	7,5	4,8	K0399.805
K0402.106	M6	M12x1,25	6	12	10,8	12,3	M12x1,25	14,5	9,5	4,8	K0399.806
K0402.108	M8	M14x1,5	7	14	12,8	14,3	M14x1,5	16,5	11,5	4,8	K0399.808
K0402.110	M10	M16x1,5	8	16	14,8	16,3	M16x1,5	18,5	13,5	4,8	K0399.810
K0402.112	M12	M18x1,5	9	18	16,8	18,3	M18x1,5	20,5	15,5	4,8	K0399.812
K0402.114	M14	M20x1,5	10	20	18,8	20,3	M20x1,5	22,5	17,5	4,8	K0399.814
K0402.116	M16	M22x1,5	11	22	20,7	22,3	M22x1,5	24,5	17,8	6,4	K0399.816
K0402.116X15	M16x1,5	M22x1,5	11	22	20,7	22,3	M22x1,5	24,5	17,8	6,4	K0399.816
K0402.118X15	M18x1,5	M24x1,5	12	24	22,5	24,3	M24x1,5	26,5	19,8	6,4	K0399.818
K0402.120	M20	M30x2	15	30	28	30,3	M30x2	34,5	25,8	6,4	K0399.820

K0653

Repair kit

**Material:**

Threaded insert in steel.

Version:

Passivated.

Sample order:

K0653.01

Note:

The repair kit allows threaded holes which have been damaged, torn out or jammed to be used again or to be repaired. This makes it possible to recover scrap and rejects of expensive products.

Threaded inserts are suitable for use in various materials, including light metals and casting.

Inserts with internal threads larger than M6 are supplied with four locking pins instead of two.

Permissible deviations:

the medium tolerance class applies to the threads listed, i.e. 6H for nut threads and 6g for bolt threads. Other dimensions ± 0.25 mm.

Technical information see operating instructions for threaded inserts.

Advantages:

- Quick and easy installation.
- The insert is fixed with pins in order to prevent torsion due to twisting or vibrations.
- No other special tools are required besides the assembly tool.



KIPP Repair kit

Order No.	Threaded inserts supplied internal thread	Threaded inserts supplied external thread	Length of inserts	Number of inserts	Number of assembly tool	Order No. Threaded insert
K0653.01	M5	M8	8	8	1	K0398.05
	M6	M10x1,25	10	8	1	K0398.06
	M8	M12x1,25	12	6	1	K0398.08
	M8x1	M12x1,25	12	6	-	K0398.08X1
	M10	M14x1,5	14	4	1	K0398.10
	M10x1,25	M14x1,5	14	4	-	K0398.10X125
	M12	M16x1,5	16	3	1	K0398.12
	M12x1,25	M16x1,5	16	3	-	K0398.12X125

Threaded inserts self-tapping

with cutting bores

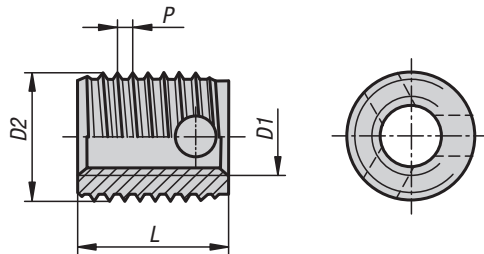
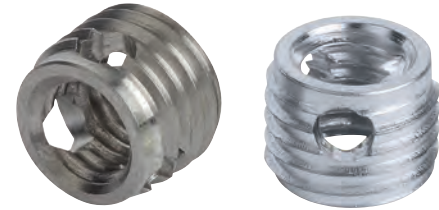
Material:

Steel or 1.4305 stainless steel

Version:

Steel case hardened, galvanised.
Stainless steel bright.

Sample order:

K0979.03

Note:

Self-tapping threaded inserts for making high-strength, wear-free, vibration resistant screw connections in materials with low shear strength such as aluminium and aluminium alloys, brass, bronze, cast iron, duro and thermoplastics.

The threaded inserts are tapered at the bottom and have three cutting bores. They cut their own threads inside a receiver hole. This guarantees a completely secure and firm anchoring in the host material.

Internal thread D1 acc. to ISO 6H.

The threaded inserts with cutting bores are designed especially for materials difficult to machine. Due to the thicker wall, it can withstand greater force during cutting, which is also distributed over three cutting bores.

KIPP Threaded inserts self-tapping with cutting bores

Order No.	Main material	D1	D2	P	L	T min.	R min. light metal	R min. cast iron	R min. plastics	Order No. Hand ass. tool	Order No. M/C ass. tool
K0979.03	Steel	M3	5	0,6	4	6	1	1,5	1,25	K0978.803	K0978.903
K0979.04	Steel	M4	6,5	0,8	6	8	1,3	1,95	1,6	K0978.804	K0978.904
K0979.05	Steel	M5	8	1	7	9	1,6	2,4	2	K0978.805	K0978.905
K0979.06	Steel	M6	10	1,25	8	10	2	3	2,5	K0978.806	K0978.906
K0979.08	Steel	M8	12	1,5	9	11	2,4	3,6	3	K0978.808	K0978.908
K0979.10	Steel	M10	14	1,5	10	13	2,8	4,2	3,5	K0978.810	K0978.910
K0979.12	Steel	M12	16	1,75	12	15	3,2	4,8	4	K0978.812	K0978.912
K0979.103	Stainless steel	M3	5	0,6	4	6	1	1,5	1,25	K0978.803	K0978.903
K0979.104	Stainless steel	M4	6,5	0,8	6	8	1,3	1,95	1,6	K0978.804	K0978.904
K0979.105	Stainless steel	M5	8	1	7	9	1,6	2,4	2	K0978.805	K0978.905
K0979.106	Stainless steel	M6	10	1,25	8	10	2	3	2,5	K0978.806	K0978.906
K0979.108	Stainless steel	M8	12	1,5	9	11	2,4	3,6	3	K0978.808	K0978.908
K0979.110	Stainless steel	M10	14	1,5	10	13	2,8	4,2	3,5	K0978.810	K0978.910
K0979.112	Stainless steel	M12	16	1,75	12	15	3,2	4,8	4	K0978.812	K0978.912

Threaded inserts self-tapping

with cutting slot

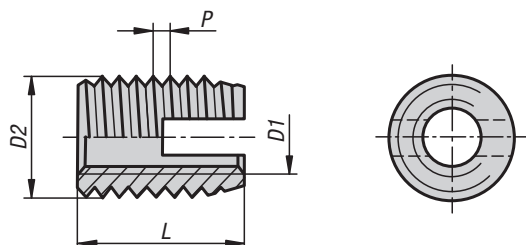
Material:

Steel or 1.4305 stainless steel

Version:

Steel case hardened, galvanised.
Stainless steel bright.

Sample order:

K0978.03

Note:

Self-tapping threaded inserts for making high-strength, wear-free, vibration resistant screw connections in materials with low shear strength such as aluminium and aluminium alloys, brass, bronze, cast iron, duro and thermoplastics.

The threaded inserts are tapered at the bottom and have a cutting slot. By screwing in they cut their own threads inside a receiver hole. This guarantees a completely secure and firm anchoring in the host material.

Internal thread D1 acc. to ISO 6H.

The threaded inserts with cutting slot spring slightly inwards in the slot region in some materials. This results in a screw locking effect. If this is not desired, we recommend the threaded inserts with a cutting bore.

KIPP Threaded inserts self-tapping with cutting slot

Order No.	Main material	D1	D2	P	L	T min.	R min. light metal	R min. cast iron	R min. plastics	Order No. Hand ass. tool	Order No. M/C ass. tool
K0978.03	steel	M3	5	0,5	6	8	1	1,5	1,25	K0978.803	K0978.903
K0978.04	steel	M4	6,5	0,75	8	10	1,3	1,95	1,6	K0978.804	K0978.904
K0978.05	steel	M5	8	1	10	13	1,6	2,4	2	K0978.805	K0978.905
K0978.06	steel	M6	10	1,5	14	17	2	3	2,5	K0978.806	K0978.906
K0978.08	steel	M8	12	1,5	15	18	2,4	3,6	3	K0978.808	K0978.908
K0978.10	steel	M10	14	1,5	18	22	2,8	4,2	3,5	K0978.810	K0978.910
K0978.12	steel	M12	16	1,5	22	26	3,2	4,8	4	K0978.812	K0978.912
K0978.16	steel	M16	20	1,5	22	27	4	6	5	-	K0978.916
K0978.103	stainless steel	M3	5	0,5	6	8	1	1,5	1,25	K0978.803	K0978.903
K0978.104	stainless steel	M4	6,5	0,75	8	10	1,3	1,95	1,6	K0978.804	K0978.904
K0978.105	stainless steel	M5	8	1	10	13	1,6	2,4	2	K0978.805	K0978.905
K0978.106	stainless steel	M6	10	1,5	14	17	2	3	2,5	K0978.806	K0978.906
K0978.108	stainless steel	M8	12	1,5	15	18	2,4	3,6	3	K0978.808	K0978.908
K0978.110	stainless steel	M10	14	1,5	18	22	2,8	4,2	3,5	K0978.810	K0978.910
K0978.112	stainless steel	M12	16	1,5	22	26	3,2	4,8	4	K0978.812	K0978.912
K0978.116	stainless steel	M16	20	1,5	22	27	4	6	5	-	K0978.916



Studs

with screw-in stop for gluing in

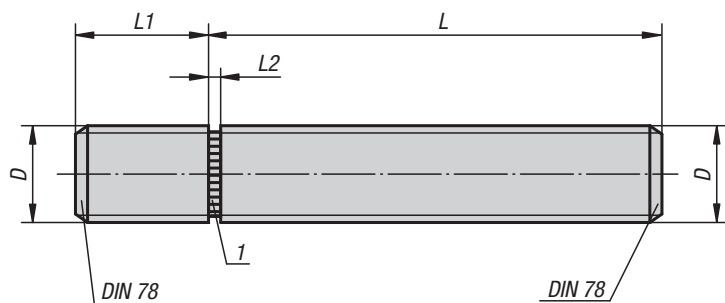

Material:

Steel or 1.4305 stainless steel

Version:

Steel blue passivated.
Stainless steel, bright.

Sample order:

K0404.1040201

Note:

Studs with screw-in stop have been designed especially for gluing-in. They allow mechanical connecting elements with external thread to be made cost-effectively for small and medium-sized series. The LOCTITE products 638 and 648 (see K0655) have proven themselves in practice as successful bonding agents.

Drawing reference:

1) screw-in stop

KIPP Studs with screw-in stop

Order No. Steel	Order No. Stainless steel	D	L	L1	L2
K0404.1040201	K0404.1040202	M4	20	6	1
K0404.1040301	K0404.1040302	M4	30	6	1
K0404.1040401	K0404.1040402	M4	40	6	1
K0404.1040501	K0404.1040502	M4	50	6	1
K0404.1050201	K0404.1050202	M5	20	8	1
K0404.1050301	K0404.1050302	M5	30	8	1
K0404.1050401	K0404.1050402	M5	40	8	1
K0404.1050501	K0404.1050502	M5	50	8	1
K0404.1050601	K0404.1050602	M5	60	8	1
K0404.1060201	K0404.1060202	M6	20	9	1,5
K0404.1060301	K0404.1060302	M6	30	9	1,5
K0404.1060401	K0404.1060402	M6	40	9	1,5
K0404.1060501	K0404.1060502	M6	50	9	1,5
K0404.1060601	K0404.1060602	M6	60	9	1,5
K0404.1080201	K0404.1080202	M8	20	12	1,5
K0404.1080301	K0404.1080302	M8	30	12	1,5
K0404.1080401	K0404.1080402	M8	40	12	1,5
K0404.1080501	K0404.1080502	M8	50	12	1,5
K0404.1080601	K0404.1080602	M8	60	12	1,5
K0404.1080801	K0404.1080802	M8	80	12	1,5
K0404.1100201	K0404.1100202	M10	20	14	2
K0404.1100301	K0404.1100302	M10	30	14	2
K0404.1100401	K0404.1100402	M10	40	14	2
K0404.1100501	K0404.1100502	M10	50	14	2
K0404.1100601	K0404.1100602	M10	60	14	2
K0404.1100801	K0404.1100802	M10	80	14	2
K0404.1120301	K0404.1120302	M12	30	17	2
K0404.1120401	K0404.1120402	M12	40	17	2
K0404.1120501	K0404.1120502	M12	50	17	2
K0404.1120601	K0404.1120602	M12	60	17	2
K0404.1120801	K0404.1120802	M12	80	17	2
K0404.1160301	K0404.1160302	M16	30	22	2
K0404.1160401	K0404.1160402	M16	40	22	2
K0404.1160501	K0404.1160502	M16	50	22	2
K0404.1160601	K0404.1160602	M16	60	22	2
K0404.1160801	K0404.1160802	M16	80	22	2

Stud sets

with screw-in stop for gluing in

Material:

Steel or 1.4305 stainless steel

Version:

Steel blue passivated.
Stainless steel, bright.

Sample order:

K0405.01

Note:

Studs with screw-in stop have been designed especially for gluing-in. They allow mechanical connecting elements with external thread to be made cost-effectively for small and medium-sized series. The LOCTITE products 638 and 648 have proven themselves in practice as a successful bonding agent. Technical data see K0404.

Safety:

Safety information is available on our internet site.

KIPP Stud sets with screw-in stop

Order No. Steel	Order No. Stainless steel	Content (pcs.) (LOCTITE adhesives 638 and 648 not included)
K0405.01	K0405.02	M5x20 (x20), M5x40 (x20), M5x60 (x10), M6x20 (x20), M6x40 (x20), M6x60 (x10), M8x20 (x10), M8x40 (x10), M8x60 (x6), M10x20 (x10), M10x40 (x10), M10x60 (x6), M12x40 (x6), M12x60 (x6)

KIPP LOCTITE adhesives (accessories)

Order No.	Version	Container	Shearing strength N/mm ²	Break-away torque Nm	Temperature resistance
K0655.6380010	LOCTITE 638	10 ml bottle	20-35	35-60	-55 °C up to 150 °C
K0655.6480010	LOCTITE 648	10 ml bottle	16-30	30-55	-55 °C up to 175 °C



K0755

Tommy bars

with fixed or sliding T-bar, DIN 6305 or DIN 6307

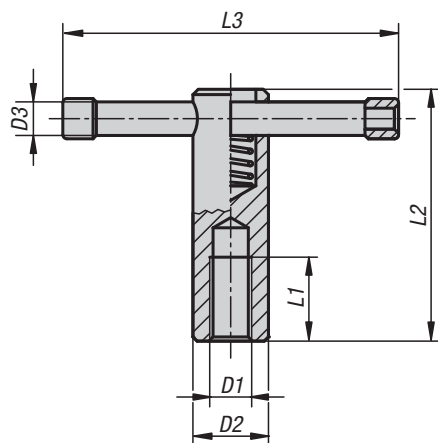
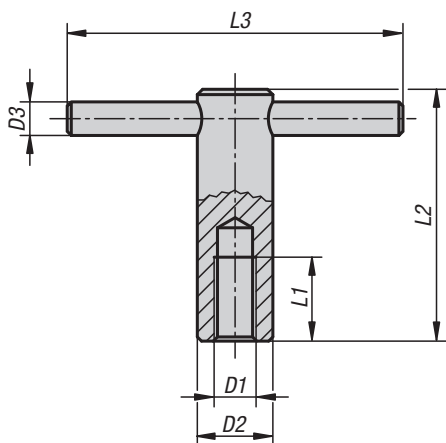

Material:
Steel.

Version:
Black oxidised.

Sample order:
K0755.210

Note:
By the version with sliding T-bar the bar is held in any desired position by a spring in the body. End stops prevent the bar falling out.
By the version with fixed T-bar the bar is pressed in.

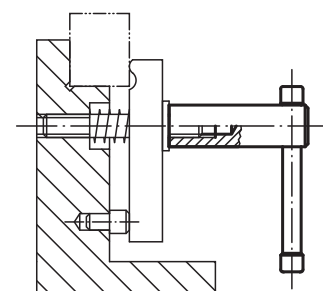

KIPP Tommy bars with fixed or sliding T-bar, DIN 6305 or DIN 6307

Order No.	Version	D1	D2	D3	L1	L2	L3
K0755.110	fixed T-bar	M10	18	8	20	60	80
K0755.112	fixed T-bar	M12	20	10	25	70	100
K0755.116	fixed T-bar	M16	24	12	35	85	120
K0755.120	fixed T-bar	M20	30	16	40	95	140
K0755.210	sliding T-bar	M10	18	8	20	60	80
K0755.212	sliding T-bar	M12	20	10	25	70	100
K0755.216	sliding T-bar	M16	24	13	35	85	120
K0755.220	sliding T-bar	M20	30	16	40	95	140

K0756



T-thrust screws

with fixed or sliding T-bar, DIN 6304 or DIN 6306



Material:
Steel.

Version:
Black oxidised. Thrust pin hardened.

Sample order:
K0756.106X40

Note:
By the thrust screws with sliding T-bar the bar is held in any desired position by a spring in the body. End stops prevent the bar falling out. By the fixed handles the T-bar is pressed in.

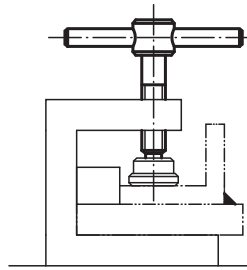
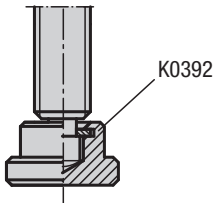
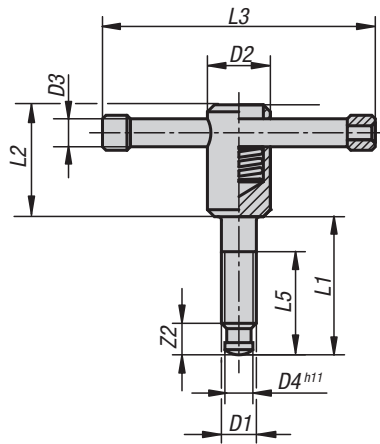
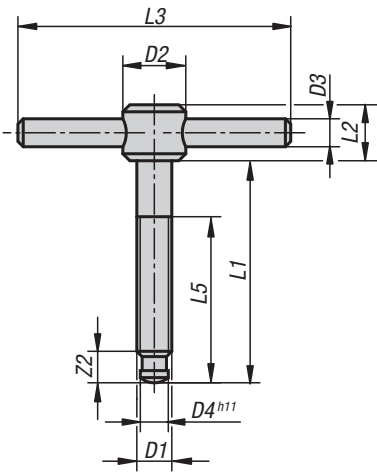

KIPP T-thrust screws with fixed or sliding T-bar, DIN 6304 or DIN 6306

Order No.	Version	L1	D1	D2	D3	D4	L2	L3	L5	Z2
K0756.106X40	fixed T-bar	40	M6	12	5	4,5	10	50	30	6
K0756.106X50	fixed T-bar	50	M6	12	5	4,5	10	50	40	6
K0756.108X50	fixed T-bar	50	M8	14	6	6	12	60	35	7,5
K0756.108X60	fixed T-bar	60	M8	14	6	6	12	60	45	7,5
K0756.110X60	fixed T-bar	60	M10	18	8	8	14	80	40	9
K0756.110X70	fixed T-bar	70	M10	18	8	8	14	80	50	9
K0756.112X70	fixed T-bar	70	M12	20	10	8	18	100	50	10
K0756.112X80	fixed T-bar	80	M12	20	10	8	18	100	60	10
K0756.116X75	fixed T-bar	75	M16	24	12	12	20	120	55	12
K0756.116X90	fixed T-bar	90	M16	24	12	12	20	120	70	12
K0756.116X110	fixed T-bar	110	M16	24	12	12	20	120	90	12
K0756.120X75	fixed T-bar	75	M20	30	16	15,5	28	140	55	14
K0756.120X90	fixed T-bar	90	M20	30	16	15,5	28	140	70	14
K0756.120X110	fixed T-bar	110	M20	30	16	15,5	28	140	90	14
K0756.210X40	sliding T-bar	40	M10	18	8	8	32	80	30	9
K0756.210X50	sliding T-bar	50	M10	18	8	8	32	80	40	9
K0756.212X50	sliding T-bar	50	M12	20	10	8	35	100	40	10
K0756.212X60	sliding T-bar	60	M12	20	10	8	35	100	50	10
K0756.216X55	sliding T-bar	55	M16	24	13	12	40	120	45	12
K0756.216X70	sliding T-bar	70	M16	24	13	12	40	120	60	12
K0756.216X90	sliding T-bar	90	M16	24	13	12	40	120	80	12
K0756.220X55	sliding T-bar	55	M20	30	16	15,5	45	140	45	14
K0756.220X70	sliding T-bar	70	M20	30	16	15,5	45	140	60	14
K0756.220X90	sliding T-bar	90	M20	30	16	15,5	45	140	80	14



Drill bushes cylindrical

DIN 179

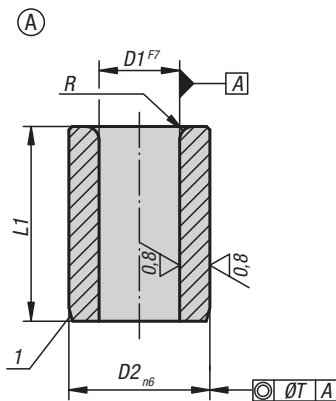
**Material:**

Special low carbon steel

Version:

Hardened to 740 ±80 HV 10 and ground.

Sample order:

K1021.A0120X06

(cylindrical drill bush, Form A with
D1 = 1.2 mm and L1 = 6 mm)**Note:**

From diameter D1 over 15 mm size increases are 0.5 mm.

Drawing reference:

Form A: hole, rounded at one end

1) Chamfer for insert

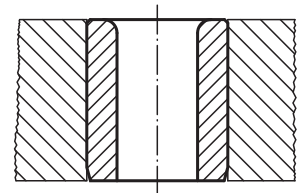

KIPP Drill bushes cylindrical DIN 179

D1	D2	L1	Version	R	T
from 0,4 to 0,8	3	6	short	1	0,01
from 0,9 to 1,0	3	6/9	short/medium	1	0,01
from 1,1 to 1,8	4	6/9	short/medium	1	0,01
from 1,9 to 2,6	5	6/9	short/medium	1	0,01
from 2,7 to 3,3	6	8/12/16	short/medium/long	1	0,01
from 3,4 to 4,0	7	8/12/16	short/medium/long	1	0,01
from 4,1 to 5,0	8	8/12/16	short/medium/long	1	0,01
from 5,1 to 6,0	10	10/16/20	short/medium/long	1,5	0,02
from 6,1 to 8,0	12	10/16/20	short/medium/long	1,5	0,02
from 8,1 to 10,0	15	12/20/25	short/medium/long	2	0,02
from 10,1 to 12,0	18	12/20/25	short/medium/long	2	0,02
from 12,1 to 15,0	22	16/28/36	short/medium/long	2	0,02
from 15,5 to 18,0	26	16/28/36	short/medium/long	2	0,02
from 18,5 to 22,0	30	20/36/45	short/medium/long	3	0,02
from 22,5 to 26,0	35	20/36/45	short/medium/long	3	0,02
from 26,5 to 30,0	42	25/45/56	short/medium/long	3	0,02
from 30,5 to 35,0	48	25/45/56	short/medium/long	3	0,04
from 35,5 to 42,0	55	30/56/67	short/medium/long	3,5	0,04
from 42,5 to 48,0	62	30/56/67	short/medium/long	3,5	0,04

Drill bushes flanged

DIN 172



Material:
Special steel.

Version:
Hardened and ground.
Hardness 740 ±80 HV 10

Sample order:
K1022.A0120X09
(flanged drill bush, Form A with
D1 = 1.2 mm and L1 = 9 mm)

Note:
From diameter D1 over 15 mm size increases are 0.5 mm.

Drawing reference:
Form A: hole, rounded at one end

1) Chamfer for insert

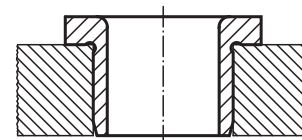
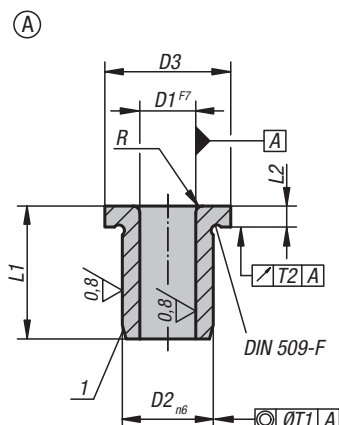

KIPP Drill bushes flanged DIN 172

D1	D2	D3	L1	Version	L2	R	T1	T2
from 0,4 to 0,8	3	6	6	short	2	1	0,01	0,03
from 0,9 to 1,0	3	6	6/9	short/medium	2	1	0,01	0,03
from 1,1 to 1,8	4	7	6/9	short/medium	2	1	0,01	0,03
from 1,9 to 2,6	5	8	6/9	short/medium	2	1	0,01	0,03
from 2,7 to 3,3	6	9	8/12/16	short/medium/length	2,5	1	0,01	0,03
from 3,4 to 4,0	7	10	8/12/16	short/medium/length	2,5	1	0,01	0,03
from 4,1 to 5,0	8	11	8/12/16	short/medium/length	2,5	1	0,01	0,03
from 5,1 to 6,0	10	13	10/16/20	short/medium/length	3	1,5	0,02	0,03
from 6,1 to 8,0	12	15	10/16/20	short/medium/length	3	1,5	0,02	0,03
from 8,1 to 10,0	15	18	12/20/25	short/medium/length	3	2	0,02	0,03
from 10,1 to 12,0	18	22	12/20/25	short/medium/length	4	2	0,02	0,03
from 12,1 to 15,0	22	26	16/28/36	short/medium/length	4	2	0,02	0,03
from 15,5 to 18,0	26	30	16/28/36	short/medium/length	4	2	0,02	0,03
from 18,5 to 22,0	30	34	20/36/45	short/medium/length	5	3	0,02	0,03
from 22,5 to 26,0	35	39	20/36/45	short/medium/length	5	3	0,02	0,05
from 26,5 to 30,0	42	46	25/45/56	short/medium/length	5	3	0,02	0,05
from 30,5 to 35,0	48	52	25/45/56	short/medium/length	5	3	0,04	0,05
from 35,5 to 42,0	55	59	30/56/67	short/medium/length	5	3,5	0,04	0,05
from 42,5 to 48,0	62	66	30/56/67	short/medium/length	6	3,5	0,04	0,05

K0406

Shaft collars set screw

DIN 705, steel

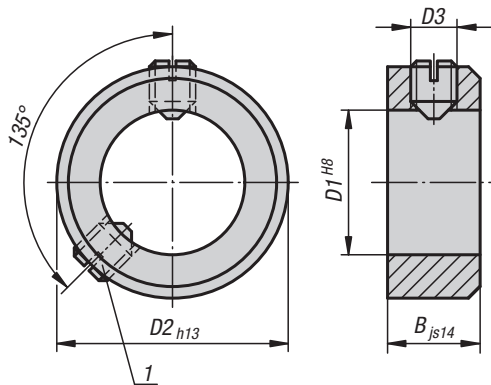
**Material:**

Steel.

Version:

Bright.

Sample order:

K0406.100301

Note:

Form A: with grub screw DIN 553 (recess)

Form E: with grub screw DIN 914 (hexagon socket)

Drawing reference:1) Second grub screw from $D1 \geq 75$

KIPP Shaft collars set screw DIN 705, steel

Order No. Form A	Order No. Form E	D1	B	D2	D3 grub screw
K0406.100301	K0406.300301	3	5	7	M2x3
K0406.100401	K0406.300401	4	5	8	M2,5x3
K0406.100501	K0406.300501	5	6	10	M3x4
K0406.100601	K0406.300601	6	8	12	M4x5
K0406.100701	K0406.300701	7	8	12	M4x5
K0406.100801	K0406.300801	8	8	16	M4x6
K0406.100901	K0406.300901	9	10	18	M5x8
K0406.101001	K0406.301001	10	10	20	M5x8
K0406.101101	K0406.301101	11	10	20	M5x8
K0406.101201	K0406.301201	12	12	22	M6x8
K0406.101401	K0406.301401	14	12	25	M6x8
K0406.101501	K0406.301501	15	12	25	M6x8
K0406.101601	K0406.301601	16	12	28	M6x8
K0406.101801	K0406.301801	18	14	32	M6x8

Shaft collars set screw

DIN 705, steel



KIPP Shaft collars set screw DIN 705, steel

Order No. Form A	Order No. Form E	D1	B	D2	D3 set screw
K0406.102001	K0406.302001	20	14	32	M6x8
K0406.102401	K0406.302401	24	16	40	M8x12
K0406.102501	K0406.302501	25	16	40	M8x10
K0406.102601	K0406.302601	26	16	40	M8x10
K0406.102801	K0406.302801	28	16	45	M8x12
K0406.103001	K0406.303001	30	16	45	M8x10
K0406.103201	K0406.303201	32	16	50	M8x12
K0406.103501	K0406.303501	35	16	56	M8x12
K0406.103601	K0406.303601	36	16	56	M8x12
K0406.103801	K0406.303801	38	16	56	M8x12
K0406.104001	K0406.304001	40	18	63	M10x16
K0406.104201	K0406.304201	42	18	63	M10x16
K0406.104501	K0406.304501	45	18	70	M10x16
K0406.104801	K0406.304801	48	18	70	M10x16
K0406.105001	K0406.305001	50	18	80	M10x16
K0406.105601	K0406.305601	56	18	80	M10x16
K0406.105201	K0406.305201	52	18	80	M10x16
K0406.105501	K0406.305501	55	18	80	M10x16
K0406.105801	K0406.305801	58	20	90	M10x16
K0406.106001	K0406.306001	60	20	90	M10x16
K0406.106301	K0406.306301	63	20	90	M10x16
K0406.106801	K0406.306801	68	20	100	M10x20
K0406.106501	K0406.306501	65	20	100	M10x20
K0406.107001	K0406.307001	70	20	100	M10x20
K0406.107201	K0406.307201	72	22	110	M10x20
K0406.107501	K0406.307501	75	22	110	M12x20
K0406.108001	K0406.308001	80	22	110	M12x20
K0406.108501	K0406.308501	85	22	125	M12x25
K0406.109001	K0406.309001	90	22	125	M12x20
K0406.110001	K0406.310001	100	25	140	M12x25



K0406

Shaft collars set screw

DIN 705, stainless steel

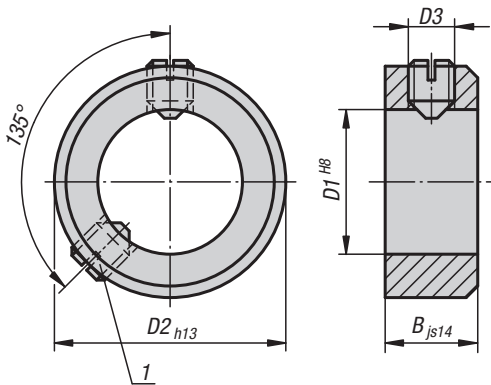
**Material:**
Stainless steel 1.4305.**Version:**
Bright.**Sample order:**
K0406.100302**Note:**
Form A: with grub screw DIN 553 (recess)
Form E: with grub screw DIN 914 (hexagon socket)**Drawing reference:**
1) Second grub screw from $D1 \geq 75$ 

KIPP Shaft collars set screw DIN 705, stainless steel

Order No. Form A	Order No. Form E	D1	B	D2	D3 grub screw
K0406.100302	K0406.300302	3	5	7	M2x3
K0406.100402	K0406.300402	4	5	8	M2,5x3
K0406.100502	K0406.300502	5	6	10	M3x4
K0406.100602	K0406.300602	6	8	12	M4x5
K0406.100702	K0406.300702	7	8	12	M4x5
K0406.100802	K0406.300802	8	8	16	M4x6
K0406.100902	K0406.300902	9	10	18	M5x8
K0406.101002	K0406.301002	10	10	20	M5x8
K0406.101102	K0406.301102	11	10	20	M5x8
K0406.101202	K0406.301202	12	12	22	M6x8
K0406.101402	K0406.301402	14	12	25	M6x8
K0406.101502	K0406.301502	15	12	25	M6x8
K0406.101602	K0406.301602	16	12	28	M6x8
K0406.101802	K0406.301802	18	14	32	M6x8

Shaft collars set screw

DIN 705, stainless steel



KIPP Shaft collars set screw DIN 705, stainless steel

Order No. Form A	Order No. Form E	D1	B	D2	D3 set screw
K0406.102002	K0406.302002	20	14	32	M6x8
K0406.102402	K0406.302402	24	16	40	M8x12
K0406.102502	K0406.302502	25	16	40	M8x10
K0406.102602	K0406.302602	26	16	40	M8x10
K0406.102802	K0406.302802	28	16	45	M8x12
K0406.103002	K0406.303002	30	16	45	M8x10
K0406.103202	K0406.303202	32	16	50	M8x12
K0406.103502	K0406.303502	35	16	56	M8x12
K0406.103602	K0406.303602	36	16	56	M8x12
K0406.103802	K0406.303802	38	16	56	M8x12
K0406.104002	K0406.304002	40	18	63	M10x16
K0406.104202	K0406.304202	42	18	63	M10x16
K0406.104502	K0406.304502	45	18	70	M10x16
K0406.104802	K0406.304802	48	18	70	M10x16
K0406.105002	K0406.305002	50	18	80	M10x16
K0406.105202	K0406.305202	52	18	80	M10x16
K0406.105502	K0406.305502	55	18	80	M10x16
K0406.105602	K0406.305602	56	18	80	M10x16
K0406.105802	K0406.305802	58	20	90	M10x16
K0406.106002	K0406.306002	60	20	90	M10x16
K0406.106302	K0406.306302	63	20	90	M10x16
K0406.106502	K0406.306502	65	20	100	M10x20
K0406.106802	K0406.306802	68	20	100	M10x20
K0406.107002	K0406.307002	70	20	100	M10x20
K0406.107202	K0406.307202	72	22	110	M10x20
K0406.107502	K0406.307502	75	22	110	M12x20
K0406.108002	K0406.308002	80	22	110	M12x20
K0406.108502	K0406.308502	85	22	125	M12x25
K0406.109002	K0406.309002	90	22	125	M12x20
K0406.110002	K0406.310002	100	25	140	M12x25



K0407

Shaft collars with wing grip

similar to DIN 705, steel

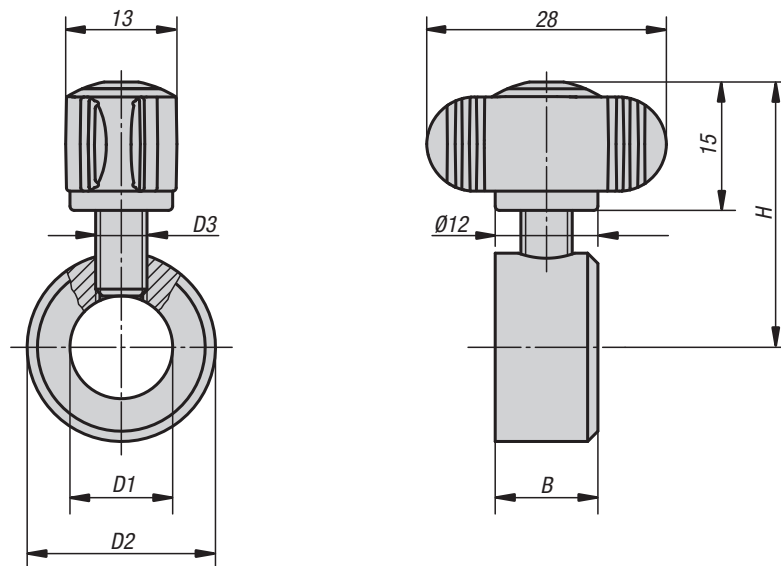
**Material:**

Shaft collar steel.

Wing grip thermoplastic.

Threaded pin steel grade 5.8.

Version:

Shaft collar bright.

Wing grip black grey.

Screw blue passivated.

Sample order:

K0407.100601

Drawing reference:

1) variable stop

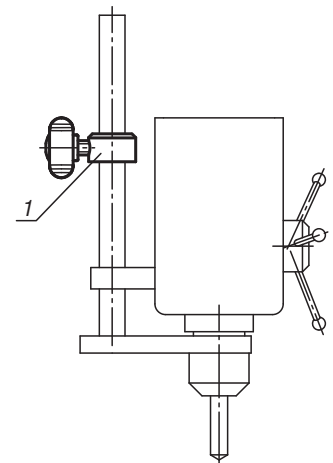
**KIPP Shaft collars with wing grip similar to DIN 705, steel**

Order No.	B	D1	D2	D3	H
K0407.100601	8	6	12	M4	26
K0407.100801	8	8	16	M4	27
K0407.101001	10	10	20	M5	30
K0407.101201	12	12	22	M6	31
K0407.101601	12	16	28	M6	33
K0407.102001	14	20	32	M6	35
K0407.102501	16	25	40	M8	37,5
K0407.103201	16	32	50	M8	46

K0611

Shaft collars one-piece

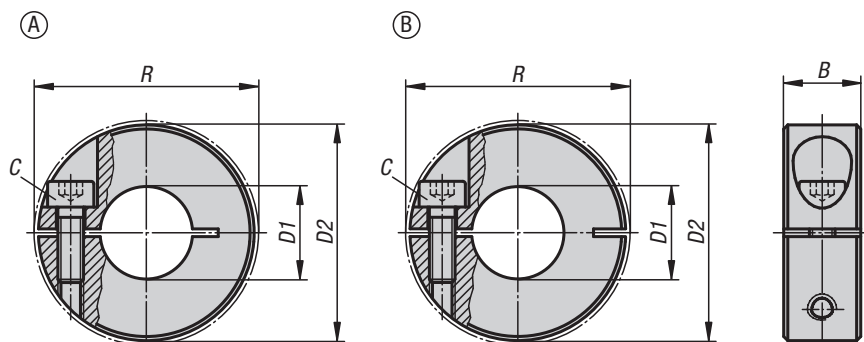

Material:

Steel 1.0718
Stainless steel 1.4305
Aluminium.

Version:

Steel black oxidised, screw steel 12.9.
Stainless steel bright, screw stainless-steel A2-70.
Aluminium bright, screw stainless-steel A2-70.

KIPP Shaft collars one-piece

Order No. steel	Order No. stainless steel	Order No. aluminium	Form	B	C (DIN 912)	D1	D2	R
K0611.00401	K0611.00402	K0611.00403	A	9	M3x8	4	16	20,7
K0611.00501	K0611.00502	K0611.00503	A	9	M3x8	5	16	20,7
K0611.00601	K0611.00602	K0611.00603	A	9	M3x8	6	16	20,7
K0611.00801	K0611.00802	K0611.00803	A	9	M3x8	8	18	22,4
K0611.01001	K0611.01002	K0611.01003	A	9	M3x10	10	24	26
K0611.01201	K0611.01202	K0611.01203	A	11	M4x12	12	28	31,8
K0611.01501	K0611.01502	K0611.01503	A	13	M5x16	15	34	39,4
K0611.01601	K0611.01602	K0611.01603	A	13	M5x16	16	34	39,4
K0611.01801	K0611.01802	K0611.01803	A	13	M5x16	18	36	41,1
K0611.02001	K0611.02002	K0611.02003	A	15	M6x18	20	40	46,4
K0611.02201	K0611.02202	K0611.02203	A	15	M6x18	22	42	48,1
K0611.02501	K0611.02502	K0611.02503	A	15	M6x18	25	45	50,8
K0611.02801	K0611.02802	K0611.02803	A	15	M6x18	28	48	53,7
K0611.03001	K0611.03002	K0611.03003	A	15	M6x18	30	54	58,6
K0611.04001	K0611.04002	K0611.04003	A	15	M6x18	40	60	65
K0611.05001	K0611.05002	K0611.05003	A	19	M8x25	50	78	87
K0611.100401	K0611.100402	K0611.100403	B	9	M3x8	4	16	20,7
K0611.100501	K0611.100502	K0611.100503	B	9	M3x8	5	16	20,7
K0611.100601	K0611.100602	K0611.100603	B	9	M3x8	6	16	20,7
K0611.100801	K0611.100802	K0611.100803	B	9	M3x8	8	18	22,4
K0611.101001	K0611.101002	K0611.101003	B	9	M3x10	10	24	26
K0611.101201	K0611.101202	K0611.101203	B	11	M4x12	12	28	31,8
K0611.101501	K0611.101502	K0611.101503	B	13	M5x16	15	34	39,4
K0611.101601	K0611.101602	K0611.101603	B	13	M5x16	16	34	39,4
K0611.101801	K0611.101802	K0611.101803	B	13	M5x16	18	36	41,1
K0611.102001	K0611.102002	K0611.102003	B	15	M6x18	20	40	46,4
K0611.102201	K0611.102202	K0611.102203	B	15	M6x18	22	42	48,1
K0611.102501	K0611.102502	K0611.102503	B	15	M6x18	25	45	50,8
K0611.102801	K0611.102802	K0611.102803	B	15	M6x18	28	48	53,7
K0611.103001	K0611.103002	K0611.103003	B	15	M6x18	30	54	58,6
K0611.104001	K0611.104002	K0611.104003	B	15	M6x18	40	60	65
K0611.105001	K0611.105002	K0611.105003	B	19	M8x25	50	78	87

Sample order:

K0611.01001

Note:

One-piece shaft collars surround the shaft with a uniformly distributed clamping force. This leads to a dimensionally precise fit and very high retaining forces without damaging the shaft.

The shaft tolerance should lie within h11.

Form A: Standard shaft collar.

Form B: Shaft collar with a ca. 15% higher clamping force than the standard version by the same tightening torque on the locking screw. The bore remains cylindrical which means that the shaft is precisely enclosed. Less imbalance.

Temperature range:

-40 °C to +175 °C.

On request:

Other dimensions.



Shaft collar

one-piece, with clamping lever

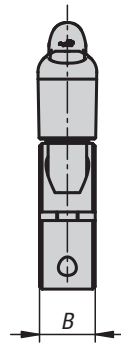
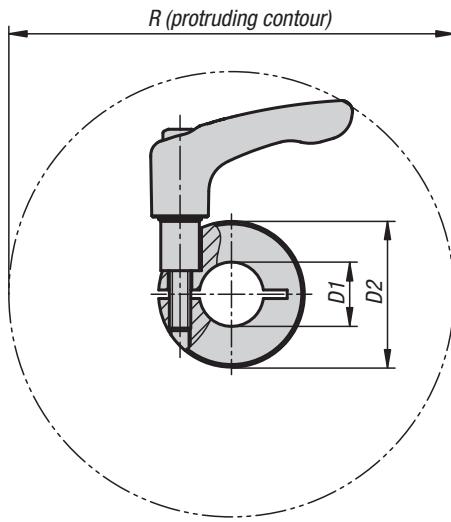

Material:

Steel 1.0718.
Stainless steel 1.4305.

Version:

Steel black oxidised.
Stainless steel bright.
Insert stainless-steel.

Sample order:

K0611.11001

Note:

One-piece shaft collars surround the shaft with an equal distribution of the clamping force. This leads to a very precise fit and high retaining force without damaging the shaft.

The shaft tolerance should lie within h11.

On request:

Other dimensions.

KIPP Shaft collar, one-piece with clamping lever

Order No. Free-cutting steel	Order No. Stainless steel	B	D1	D2	R
K0611.11001	K0611.11002	9	10	24	44,1
K0611.11201	K0611.11202	11	12	28	90,4
K0611.11501	K0611.11502	13	15	34	105
K0611.11601	K0611.11602	13	16	34	105
K0611.11801	K0611.11802	13	18	36	105,7
K0611.12001	K0611.12002	15	20	40	103,8
K0611.12201	K0611.12202	15	22	42	104,2
K0611.12501	K0611.12502	15	25	45	104,8
K0611.12801	K0611.12802	15	28	48	106,8
K0611.13001	K0611.13002	15	30	54	112,6
K0611.14001	K0611.14002	15	40	60	113,2
K0611.15001	K0611.15002	19	50	78	150,2

Shaft collars two-piece

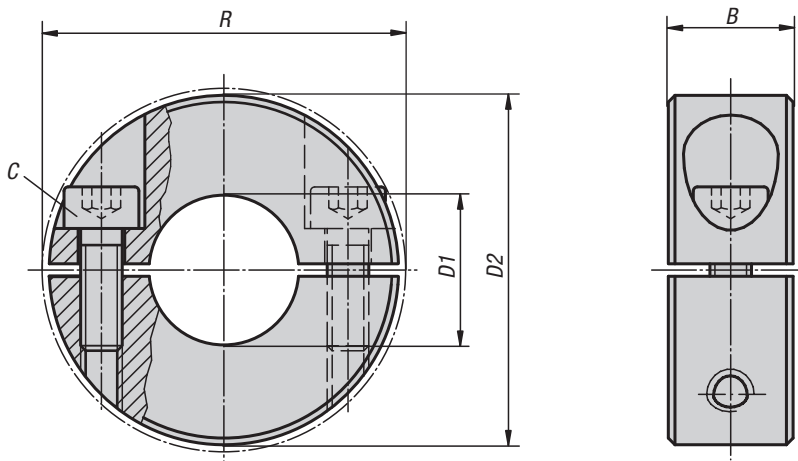
**Material:**

Steel 1.0718
Stainless steel 1.4305
Aluminium.

Version:

Steel black oxidised, screw steel 12.9.
Stainless steel bright, screw stainless-steel A2-70.
Aluminium bright, screw stainless-steel A2-70.

Sample order:

K0612.01001

Note:

Two-piece shaft collars surround the shaft with a uniformly distributed clamping force. This leads to a dimensionally precise fit and very high retaining forces without damaging the shaft.

The shaft tolerance should lie within h11.

Two-piece shaft collars can be quickly and easily mounted or removed without dismantling other components.

Temperature range:

-40 °C to +175 °C.

On request:

Other dimensions.

KIPP Shaft collars two-piece

Order No. Steel	Order No. Stainless steel	Order No. Aluminium	B	C (DIN 912)	D1	D2	R
K0612.00401	K0612.00402	K0612.00403	9	M3x8	4	16	20,7
K0612.00501	K0612.00502	K0612.00503	9	M3x8	5	16	20,7
K0612.00601	K0612.00602	K0612.00603	9	M3x8	6	16	20,7
K0612.00801	K0612.00802	K0612.00803	9	M3x8	8	18	22,4
K0612.01001	K0612.01002	K0612.01003	9	M3x10	10	24	26
K0612.01201	K0612.01202	K0612.01203	11	M4x12	12	28	31,8
K0612.01501	K0612.01502	K0612.01503	13	M5x16	15	34	39,4
K0612.01601	K0612.01602	K0612.01603	13	M5x16	16	34	39,4
K0612.01801	K0612.01802	K0612.01803	13	M5x16	18	36	41,1
K0612.02001	K0612.02002	K0612.02003	15	M6x18	20	40	46,4
K0612.02201	K0612.02202	K0612.02203	15	M6x18	22	42	48,1
K0612.02501	K0612.02502	K0612.02503	15	M6x18	25	45	50,8
K0612.02801	K0612.02802	K0612.02803	15	M6x18	28	48	53,7
K0612.03001	K0612.03002	K0612.03003	15	M6x18	30	54	58,6
K0612.04001	K0612.04002	K0612.04003	15	M6x18	40	60	65
K0612.05001	K0612.05002	K0612.05003	19	M8x25	50	78	87



K0986

Shaft collars

tapped

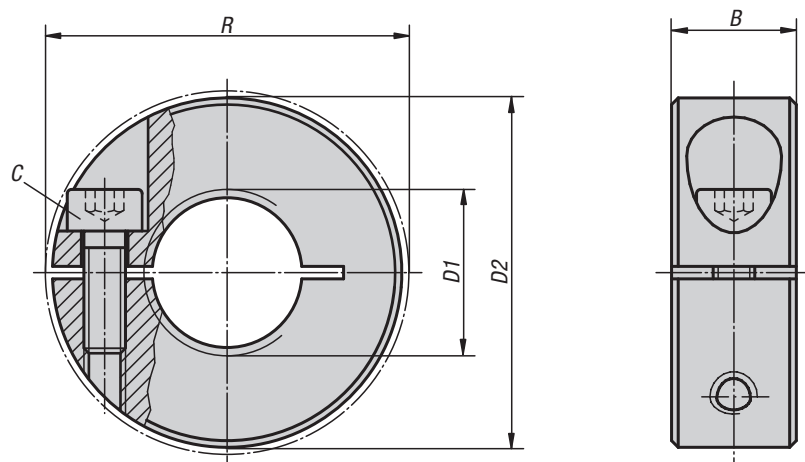
**Material:**Steel 1.0718.
Stainless steel 1.4305.**Version:**Steel black oxidised.
Screw 12.9 steel.
Stainless steel brig.ht
Screw A2-70 stainless-steel.**Sample order:**

K0986.0601

Note:Shaft collars with thread surround the shaft with an equal distribution of clamping forces.
The shaft collars can be used on threaded rods or shafts with a thread tolerance of 6g.**Temperature range:**

-40 °C to +175 °C.

KIPP Shaft collars tapped

Order No. Steel	Order No. Stainless steel	B	C	D1	D2	R
K0986.0401	K0986.0402	9	M3x8	M4	16	20,7
K0986.0501	K0986.0502	9	M3x8	M5	16	20,7
K0986.0601	K0986.0602	9	M3x8	M6	16	20,7
K0986.0801	K0986.0802	9	M3x8	M8	18	22,4
K0986.1001	K0986.1002	9	M3x10	M10	24	26
K0986.1201	K0986.1202	11	M4x12	M12	28	31,8
K0986.1601	K0986.1602	13	M5x16	M16	34	39,4
K0986.2001	K0986.2002	15	M6x18	M20	40	46,4

K0397

Clevis

with external thread

**Material:**

Carbon steel 1.1191

Version:

Tempered and black oxidised.

Sample order:

K0397.05

Note:

Suitable clevis pin see K0007.

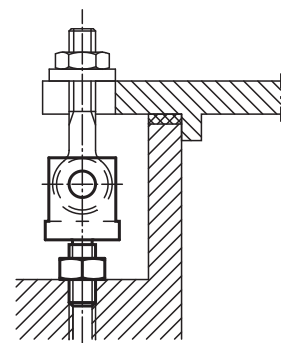
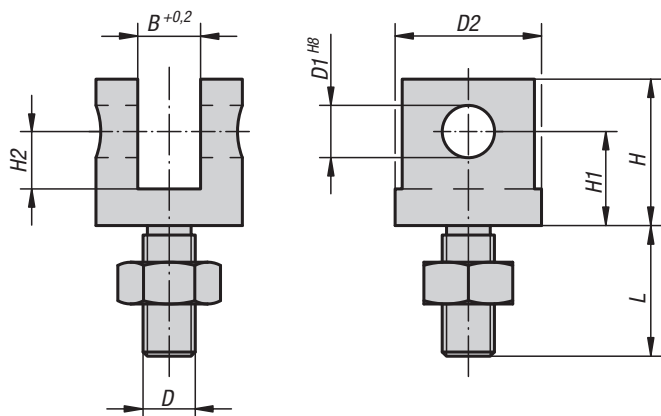
**KIPP Clevis with external thread**

Order No.	D	D1	D2	B	H	H1	H2	L
K0397.05	M5	5	12	6	16	10	7	14,5
K0397.06	M6	6	16	7	19	12	8	15
K0397.08	M8	8	20	9	23	15	10	20
K0397.10	M10	10	28	12	28	18	11	25
K0397.12	M12	12	30	14	34	21	13,5	30
K0397.14	M14	14	36	16	37	23	15	35
K0397.16	M16	16	40	17	42	26	17	40
K0397.20	M20	18	50	22	52	32	21	50

Notes



A large grid area for taking notes, consisting of a fine grid of small squares.

K0376

Clamp hubs

**Material:**

Carbon steel 1.1206.

Version:

Black oxidised.

Sample order:

K0376.1012

Note:

Clamp hubs can be quickly and easily attached to shafts, adjusted in the proper operating position and then locked. For secure transmission of torque, shaft tolerance should not exceed h11.

At fastening thread (D2), handles can be screwed on.

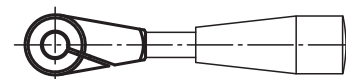
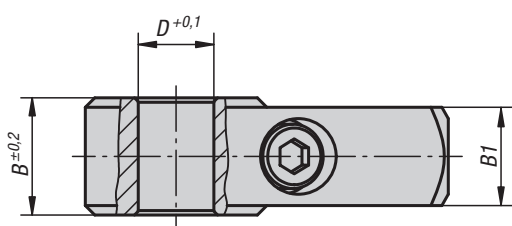
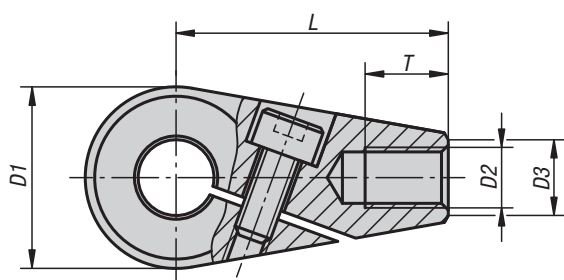

KIPP Clamp hubs

Order No.	D	D1	D2	D3	B	B1	L	T
K0376.0810	10	24	M8	10	15,5	13	36	11
K0376.0812	12	24	M8	10	15,5	13	36	11
K0376.1012	12	28	M10	12	17,5	15	41	14
K0376.1014	14	28	M10	12	17,5	15	41	14
K0376.1214	14	32	M12	14	19,5	17	45	16
K0376.1216	16	32	M12	14	19,5	17	45	16

K0133

Clamping joints



Material:

Clamping lever:
 Handle fibreglass reinforced thermoplastic, black grey.
 Steel parts:
 grade 5.8.
 Remaining components:
 high-strength aluminium.

Version:

Steel parts black oxidised.
 Aluminium nickel silver anodized.

Sample order:

K0133.03

Note:

Clamping joints are used to clamp round cross sections (bars, tubes, etc.) and are infinitely adjustable. The simple design together with the adjustable clamping lever permits rapid clamping.

Drawing reference:

1) Clamping lever

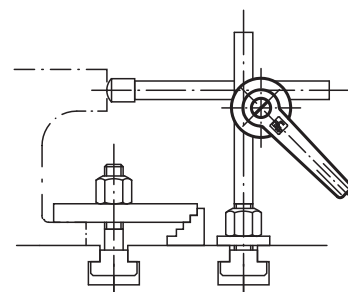
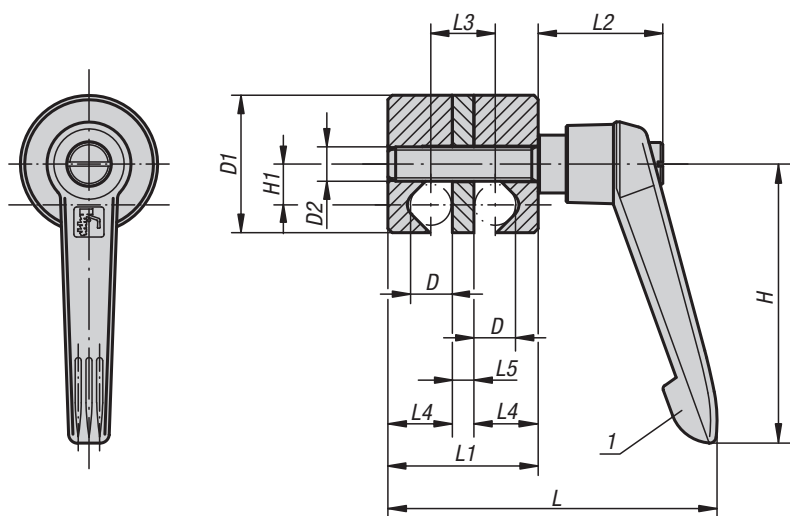

KIPP Clamping joints

Order No.	Size	D	D1	D2	L	L1	L2	L3	L4	L5	H	H1
K0133.01	1	8	28	M8	72	31	29	13	13	5	65	8,5
K0133.02	2	10	32	M8	76	35	29	15	15	5	65	9,5
K0133.03	3	12	36	M8	81	40	29	18	17	6	65	10,5
K0133.04	4	16	45	M10	103	50	37,5	22	22	6	80	13,5
K0133.05	5	20	74	M10	131	70	42,5	30	30	10	95	22

Clamping joints

individually adjustable

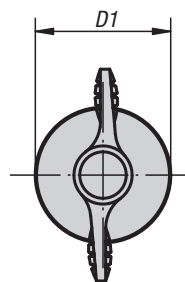
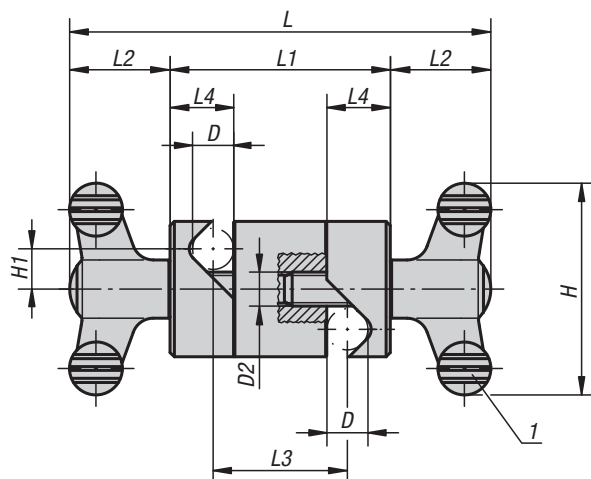

Material:

Wing grip:
grip black grey thermoplastic.
Screw steel 5.8.
Remaining components:
high-strength aluminium.

Version:

Steel parts blue-passivated.
Aluminium nickel silver anodized.

Sample order:

K0134.02

Note:

Clamping joints are used to clamp round cross sections (bars, tubes, etc.) and are individually and infinitely adjustable.

The simple design together with the wing grip permits rapid clamping.

Drawing reference:

1) wing grip

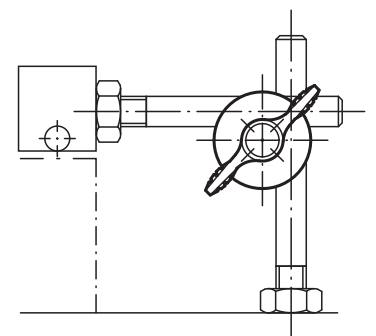

KIPP Clamping joints individually adjustable

Order No.	Size	D	D1	D2	L	L1	L2	L3	L4	H	H1
K0134.01	1	8	28	M8	90	42	24	24	13	50	8,5
K0134.02	2	10	32	M8	100	52	24	32	15	50	9,5
K0134.03	3	12	36	M8	104	56	24	34	17	50	10,5
K0134.04	4	16	45	M10	143,2	72	35,6	44	22	75	13,5
K0134.05	5	20	74	M10	173,2	102	35,6	62	30	75	22

Multiple connectors

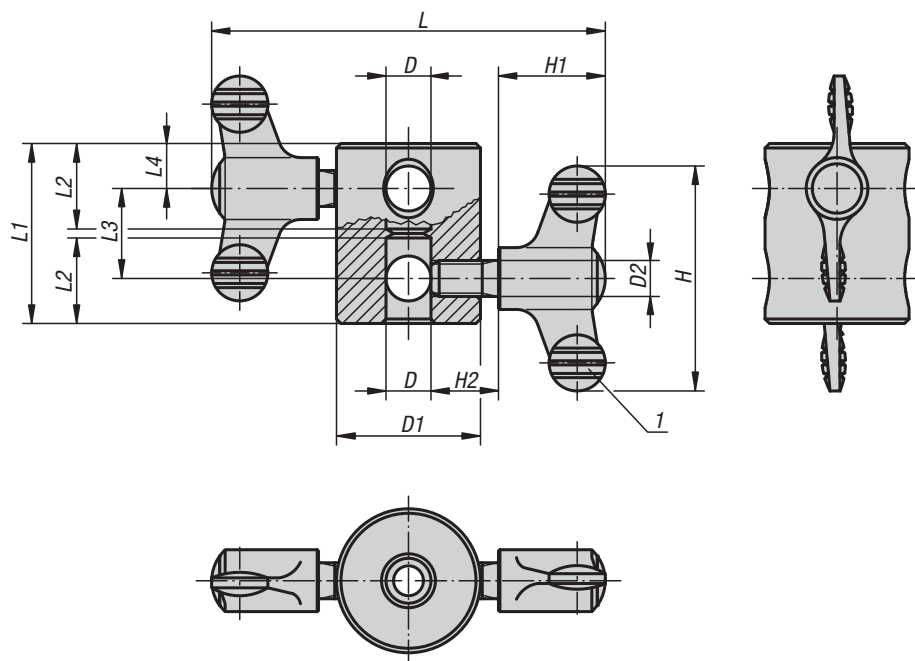
**Material:**

Wing grip:
grip black grey thermoplastic.
Screw steel 5.8.
Body:
high-strength aluminium.

Version:

Steel parts blue-passivated.
Aluminium nickel silver anodized.

Sample order:

K0135.04

Note:

Multiple connectors are used to extend round cross sections (bars, tubes, etc.) in a coaxial or parallel arrangement.

By a parallel arrangement, a strengthening or stiffening of the construction can be achieved. The bore system in the body also allows for the production of right-angled connections.

Drawing reference:

1) wing grip

Arrangement:

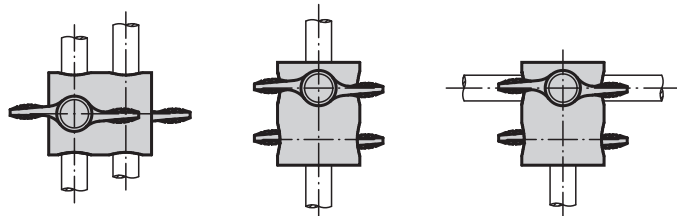

parallel

coaxial

right-angled

KIPP Multiple connectors

Order No.	Size	D	D1	D2	L	L1	L2	L3	L4	H	H1	H2
K0135.01	1	8	28	M8	86	36	17	20	8	50	24	15
K0135.02	2	10	32	M8	88	40	19	20	10	50	24	15
K0135.03	3	12	36	M8	90	44	21	20	12	50	24	15
K0135.04	4	16	45	M10	127,2	56	27	24	16	75	35,6	20

Clamping joints

**Material:**

Sleeve and pin steel.
Clamp block high-strength aluminium.
Wing grip black grey thermoplastic.

Version:

Sleeve and pin high-gloss chromed.
Clamp block black anodized.

Sample order:

K0136.1616

Note:

Infinitely adjustable.
Wing grip for rapid clamping.

On request:

Different combinations diameters D and D1.

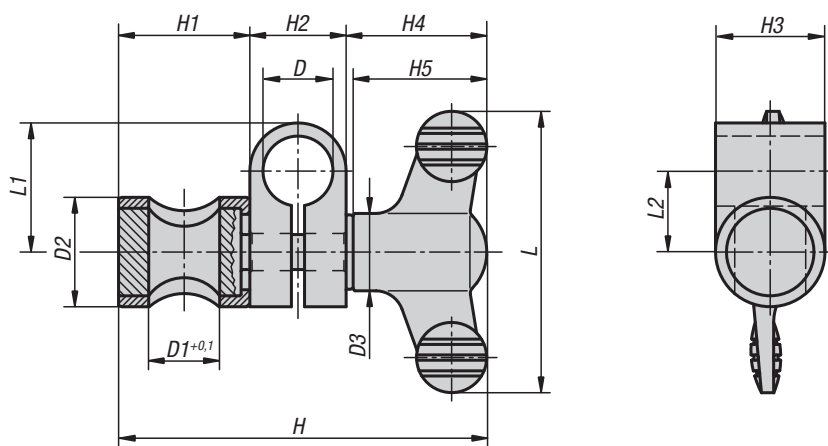

KIPP Clamping joints

Order No.	Size	D	D1	D2	D3	H	H1	H2	H3	H4	H5	L	L1	L2
K0136.0606	1	6	6	14	12	43,6	15	9	14	19,6	18	38	13	8,5
K0136.0808	2	8	8	16	14	54,6	17	12	16	25,6	24	50	18	12
K0136.1010	3	10	10	18	14	60,6	20	15	18	25,6	24	50	22	14,5
K0136.1212	4	12	12	20	21	77,2	23	17	20	37,2	35,6	75	24	15,5
K0136.1616	5	16	16	25	21	90,2	31	22	25	37,2	35,6	75	29,5	18,5
K0136.2020	6	20	20	30	21	98,2	36	25	30	37,2	35,6	75	30	17,5



K0053

Swing screws



Material:

Star grip thermoplastic.
 Bush steel.
 Washer steel 140 HV.
 Eye bolt steel grade 8.8.
 Hinge pin steel 1.1181.

Version:

Star grip black.
 Bush galvanised and blue passivated
 Washer bright.
 Eye bolt black oxidised.
 Hinge pins tempered, ground and bright.

Sample order:

K0053.06050

Note:

The swing screws are supplied unassembled.
 Suitable circlips are enclosed.

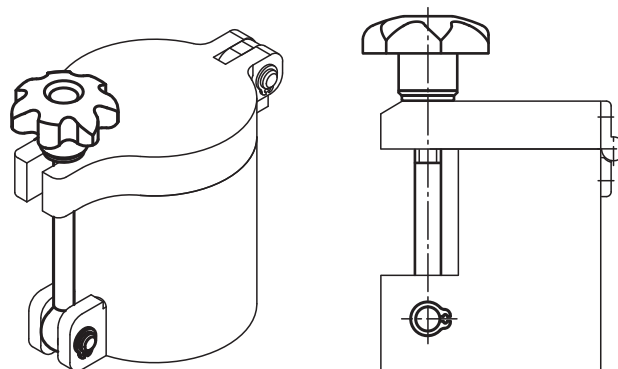
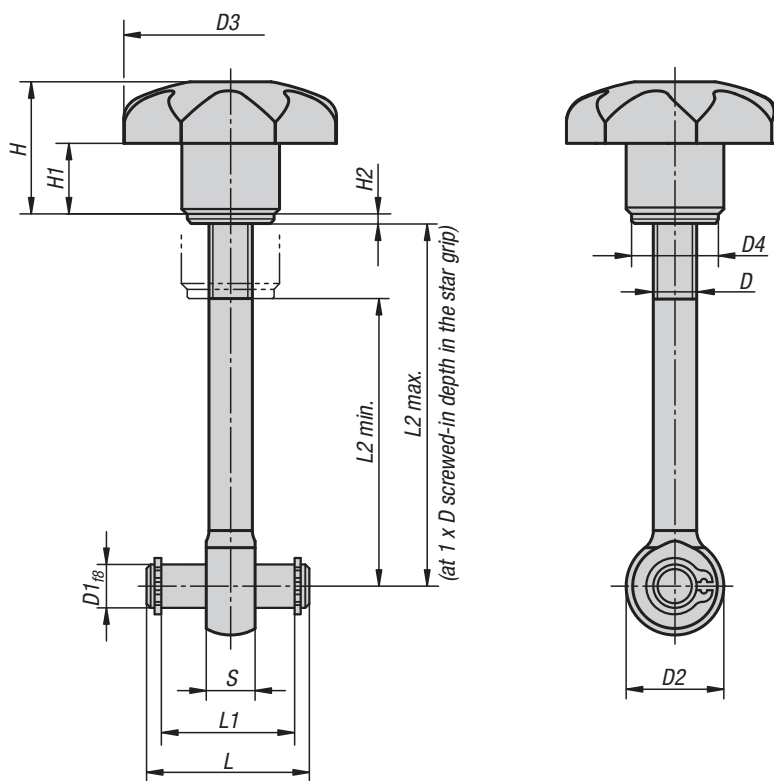

KIPP Swing screws

Order No.	D	D1	D2	D3	D4	H	H1	H2	L	L1	L2 min.	L2 max.	S
K0053.06050	M6	6	14	32	12	20	10	1,6	22	17	32	44	7
K0053.06075	M6	6	14	32	12	20	10	1,6	22	17	57	69	7
K0053.08050	M8	8	18	40	16	24	13	1,6	30	25	28	42	9
K0053.08075	M8	8	18	40	16	24	13	1,6	30	25	53	67	9
K0053.10075	M10	10	20	50	20	31	17	2	37	32	49	65	12
K0053.10100	M10	10	20	50	20	31	17	2	37	32	74	90	12

K0054

Hooks

with a quick-acting star grip



Material:

Hook steel 1.0718.
Quick-acting star grips thermoplastic.
Bush steel.
Washer steel 140 HV.

Version:

Hook and bush galvanized and blue passivated
Quick-acting star grips black.
Washer bright.

Sample order:

K0054.05075

Note:

The assembly is delivered loose.

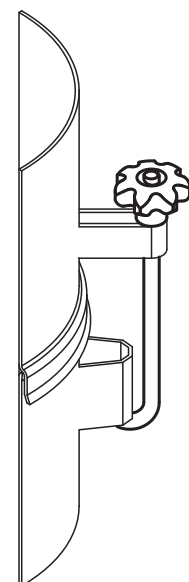
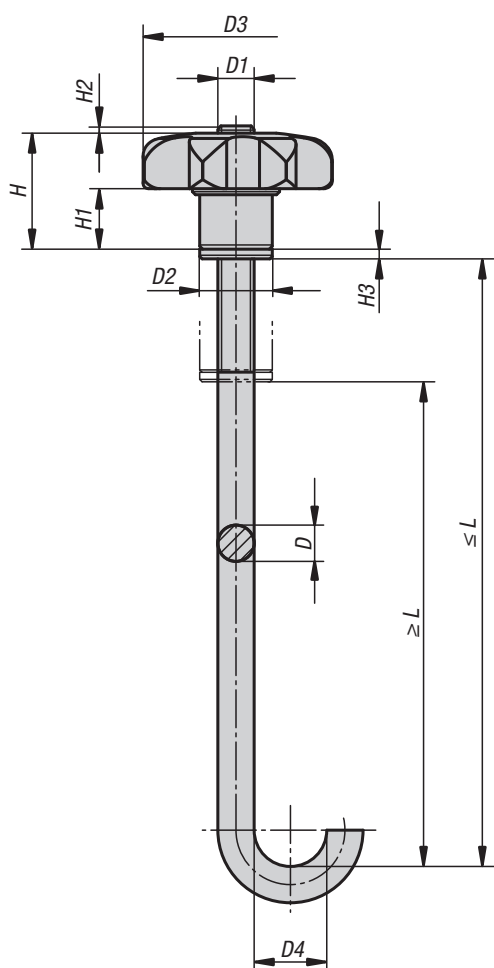

KIPP Hooks with a quick-acting star grip

Order No.	D	D1	D2	D3	D4	H	H1	H2	H3	L min.	L max.	Clamping force F (kN)
K0054.05075	5	M5	10	25	10	16,6	8	0,5	1	60	75	1
K0054.05100	5	M5	10	25	10	16,6	8	0,5	1	85	100	1
K0054.06100	6	M6	12	32	12	20,6	10	1	1,6	80	100	1,5
K0054.06125	6	M6	12	32	12	20,6	10	1	1,6	105	125	1,5
K0054.08125	8	M8	16	40	16	24,5	13	1,6	1,6	100	125	2
K0054.08140	8	M8	16	40	16	24,5	13	1,6	1,6	115	140	2

K0629

Dial gauge collets

for Ø8 shafts



Material:
Carbon steel.

Version:
Black oxidised.
Collet tempered.

Sample order:
K0629.08

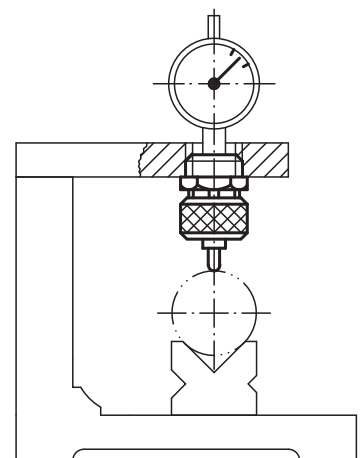
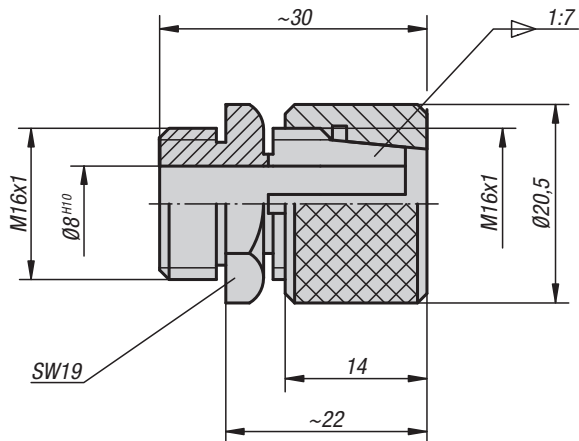

KIPP Dial gauge collets for Ø8 shafts

Order No.	Dimensions
K0629.08	see drawing

K1031



Connecting sets standard

Type I

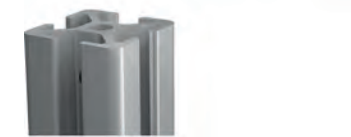
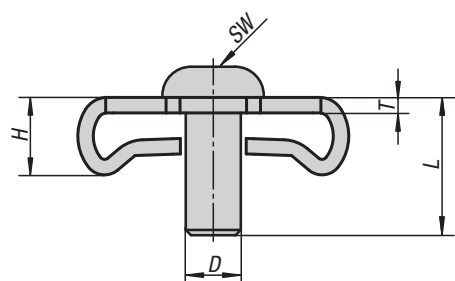
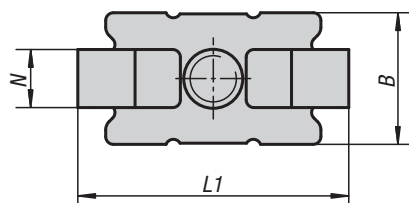

Material:
Steel.

Version:
galvanized.

Sample order:
K1031.06

Note:
The connecting sets are used for connecting two aluminium profiles at right angles. The connection is non-rotating. For larger profiles several connecting sets can be mounted on the end for greater strength

Low workload. Cut a thread in the end face core hole. Drill a through hole for tightening the screw in the opposing profile.



KIPP Connecting sets standard Type I

Order No.	Type	Slot width	D	B	H	L	L1	N	T	SW
K1031.06	I	6	M6	13	7,3	14	27,5	6	2	4
K1031.08	I	8	M8	17	9,5	20	35	8	2	5

Connecting sets universal

Type I

**Material:**

Connector die-cast zinc.
Screw and slot nuts steel.

Version:

galvanized.

Sample order:

K1032.06

Note:

The connecting sets are used for connecting two aluminium profiles at right angles. They allow a free positioning of profiles. The connection is non-rotating (the rotation lock can be broken off). For larger profiles several connecting sets can be mounted on the end for greater strength. Retrofitting into existing constructions is possible.

Low workload. The connecting set requires only one hole drilled in one end.

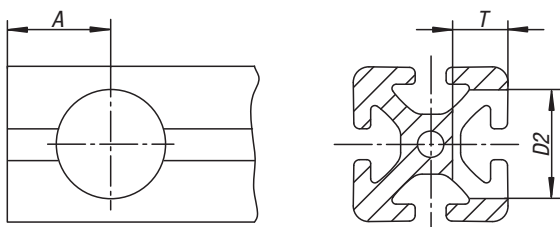
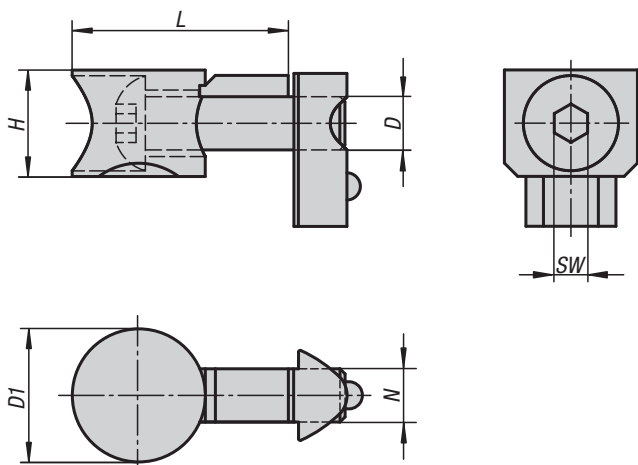

KIPP Connecting sets universal Type I

Order No.	Type	Slot width	D	D1	H	L	N	SW	A	D2	T
K1032.06	I	6	M6	16	12,5	25,2	6,2	4	15	16	12,7
K1032.08	I	8	M8	20	16	33,5	8	5	20	20	16

K1033



Connecting sets central

Type I



Material:
Steel.

Version:
galvanized.

Sample order:
K1033.0800

Note:
The connecting sets are used to connect two aluminium profiles at right angles. They allow free position of the profiles. The profile slots positioned at right-angles to each other remain free. Panel elements can be positioned in the profile grooves without additional machining.

Due to the reduced clamping force and omitted rotation locks, these connecting sets should only be used in combination with panel elements and lightly loaded constructions.

Low workload. To assemble a hole must be drilled into one of the profiles and the core hole must be drilled out.

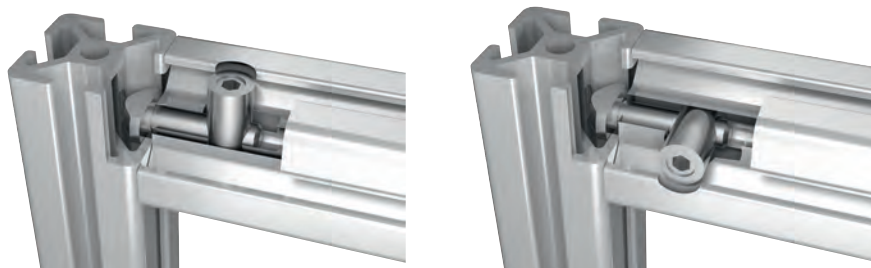
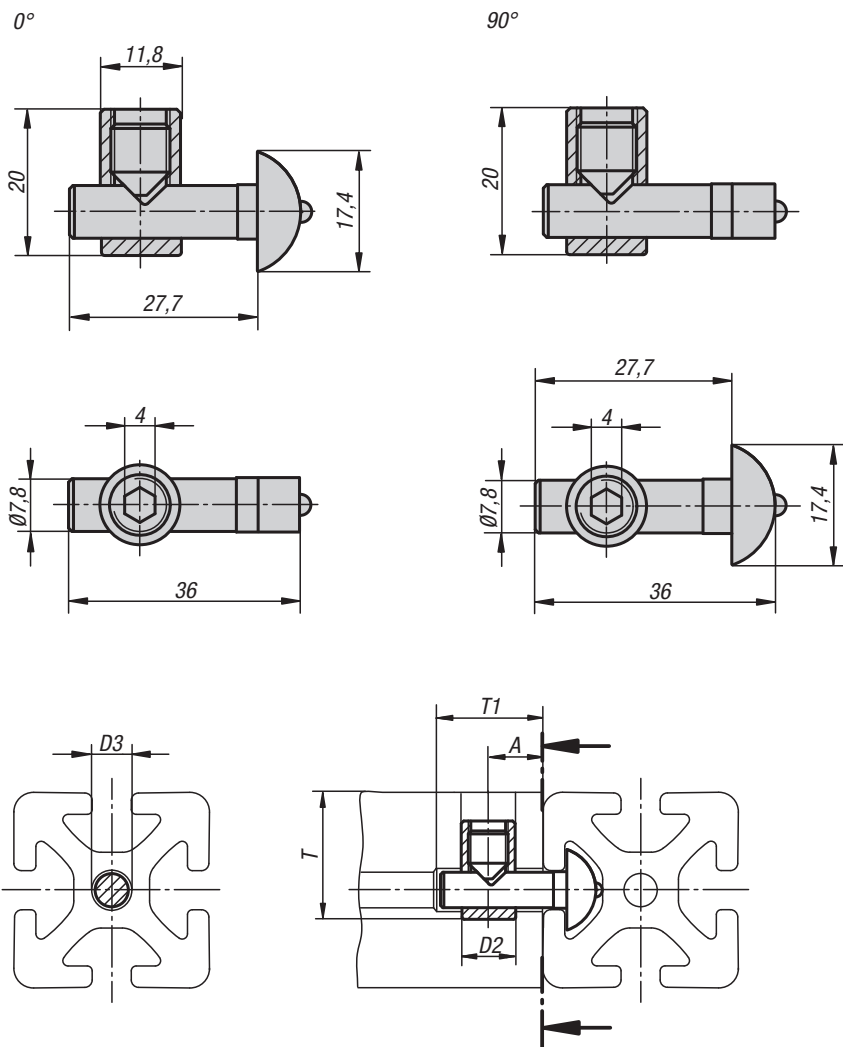

KIPP Connecting sets central Type I

Order No.	Type	Slot width	Version	A	D2	D3	T	T1
K1033.0800	I	8	0°	15	12	8	28	28
K1033.0890	I	8	90°	15	12	8	28	28

K1034



Connecting sets central

Type B



Material:
Steel.

Version:
galvanized.

Sample order:
K1034.1000

Note:
The connecting sets are used to connect two aluminium profiles at right angles. They allow free position of the profiles. The profile slots positioned at right-angles to each other remain free. Panel elements can be positioned in the profile slots without additional machining.

Due to the reduced clamping force and omitted rotation locks, these connecting sets should only be used in combination with panel elements and lightly loaded constructions.

Low workload. To assemble a hole must be drilled into one of the profiles. The D2 hole can also be drilled through.

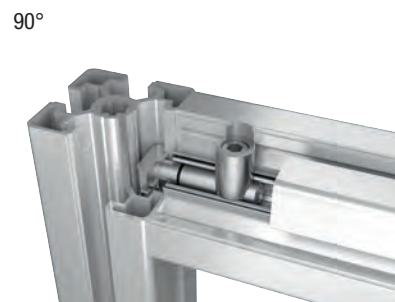
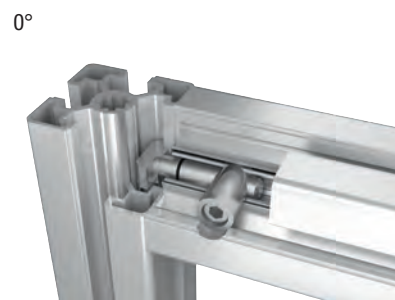
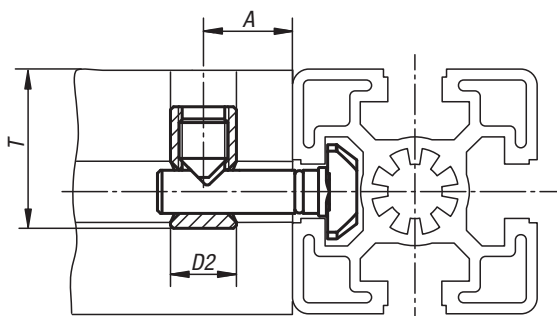
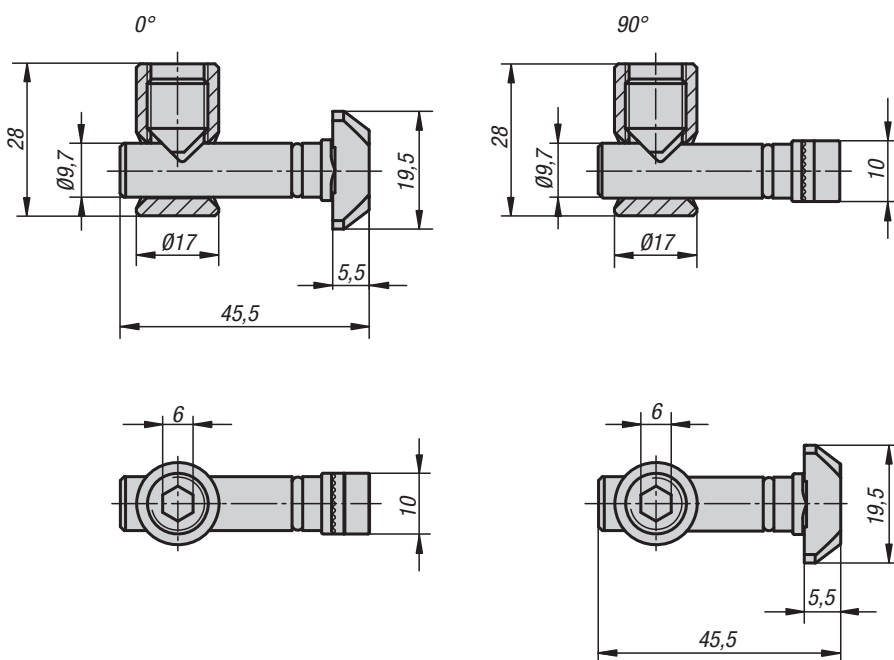

KIPP Connecting sets central Type B

Order No.	Type	Slot width	Version	A	D2	T for profile 40	T for profile 45	T for profile 50	T for profile 60
K1034.1000	B	10	0°	22,5	17	31	34	36	41
K1034.1090	B	10	90°	22,5	17	31	34	36	41

K1035



Connecting sets central

Type B

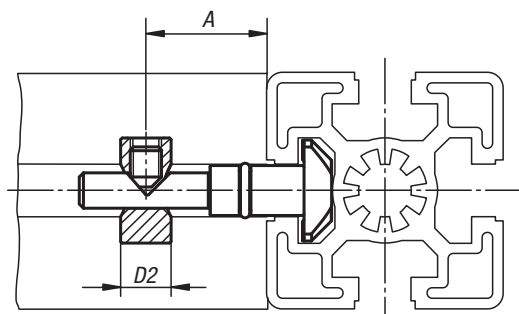
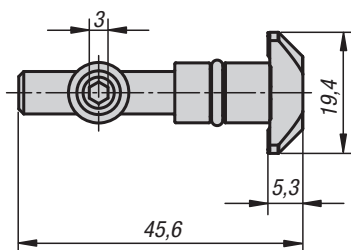
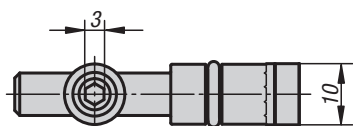
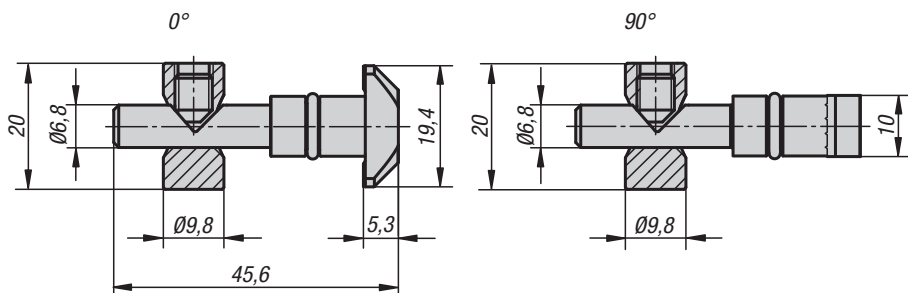

Material:
Steel.

Version:
galvanized.

Sample order:
K1035.1000

Note:
The connecting sets are used to connect two aluminium profiles at right angles. They allow free position of the profiles. The profile slots positioned at right-angles to each other remain free. Panel elements can be positioned in the profile slots without additional machining.

Due to the reduced clamping force and omitted rotation locks, these connecting sets should only be used in combination with panel elements and lightly loaded constructions.

Low workload. To assemble a hole must be drilled into one of the profiles. Due to the reduced pin diameter the slot is not damaged and can be completely covered with a cover profile.

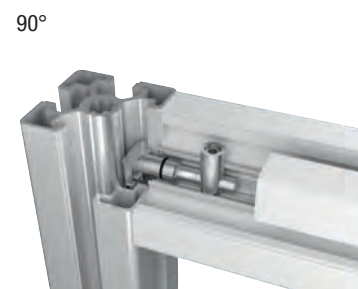
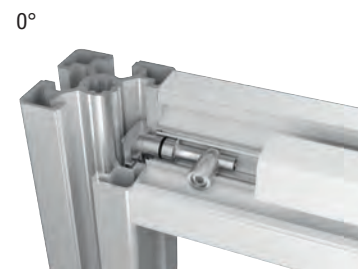

KIPP Connecting sets central Type B

Order No.	Type	Slot width	Version	A	D2
K1035.1000	B	10	0°	22,5	9,8
K1035.1090	B	10	90°	22,5	9,8

K1036

Connecting sets automatic

Type I

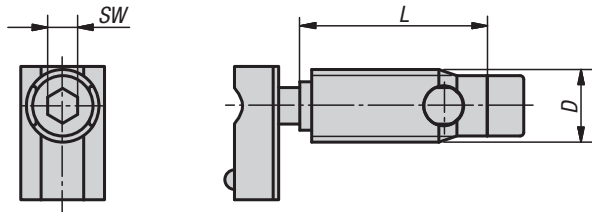
**Material:**
Steel.**Version:**
galvanized.**Sample order:**
K1036.06**Note:**

The connecting sets are used to connect two aluminium profiles at right angles. They allow free position of the profiles.

No profile machining is necessary. The connector is screwed into the profile slot from the front (left-hand thread). The connector has a self-tapping thread. The use of lubricants is recommended.

Connecting sets automatic should always be used opposite each other in pairs.

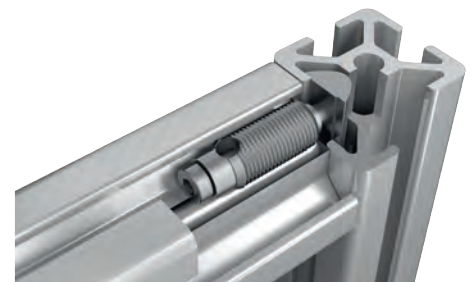

KIPP Connecting sets automatic Type I

Order No.	Type	Slot width	D	L	SW
K1036.06	I	6	10	27	4
K1036.08	I	8	12	31	5

Connecting sets automatic

Type B

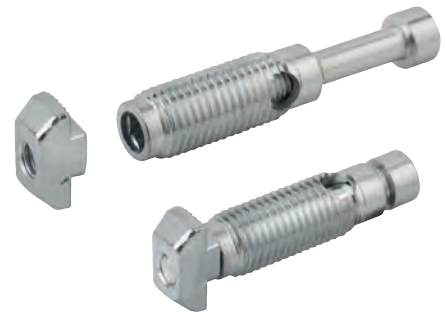

Material:
Steel.

Version:
galvanized.

Sample order:
K1037.1012

Note:

The connecting sets are used to connect two aluminium profiles at right angles. They allow free position of the profiles.

No profile machining is necessary. The connector is screwed into the profile slot from the front (left-hand thread). The connector has a self-tapping thread. The use of lubricants is recommended.

Connecting sets automatic should always be used opposite each other in pairs.

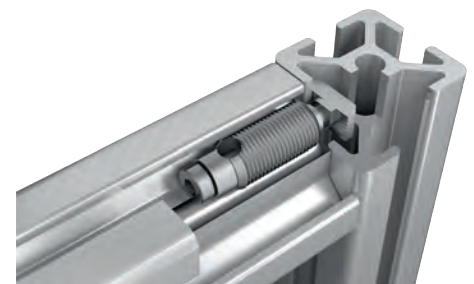

KIPP Connecting sets automatic Type B

Order No.	Type	Slot width	D	L	SW
K1037.1012	B	10	12	35	5
K1037.1013	B	10 light	13	35	5



K1038



Pin connector sets

Type B



-1040 / -1045 / -1060

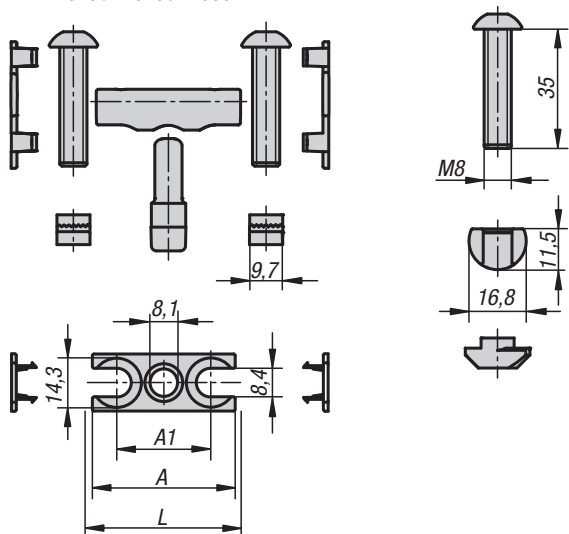

-1080 / -1090

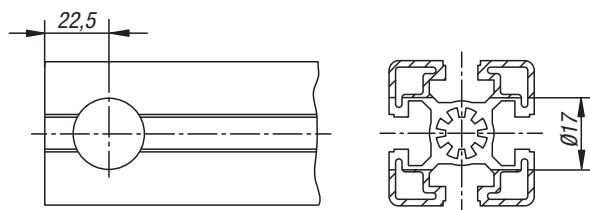
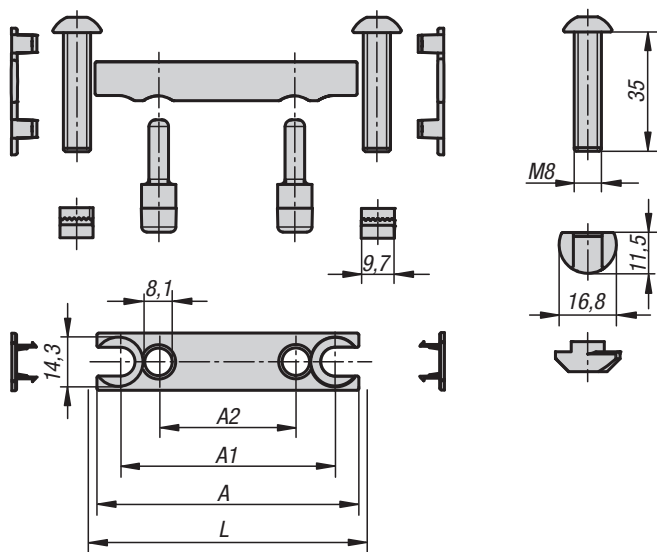

Material:

Pins, screws and T-nuts steel.
Locating pin and end caps polyamide, fibreglass reinforced.

Version:

Pins, screws and T-nuts galvanized.
Locating pin and end caps black.

Sample order:

K1038.1040

Note:

The connecting sets are used for connecting two aluminium profiles at right angles. They allow free positioning of the profiles. Suitable for high loads and absorbing torsional forces.

Low workload. The connecting set only requires one 17 mm hole drilled one side.

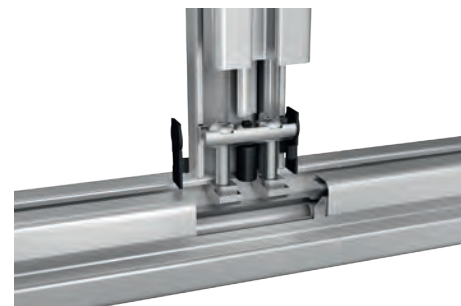

KIPP Pin connector sets Type B

Order No.	Type	Slot width	A	A1	A2	L
K1038.1040	B	10	37	23	-	40
K1038.1045	B	10	42	28	-	45
K1038.1060	B	10	57	43	-	60
K1038.1080	B	10	77	63	40	80
K1038.1090	B	10	87	73	45	90

Cube connector sets

Type B



2-D

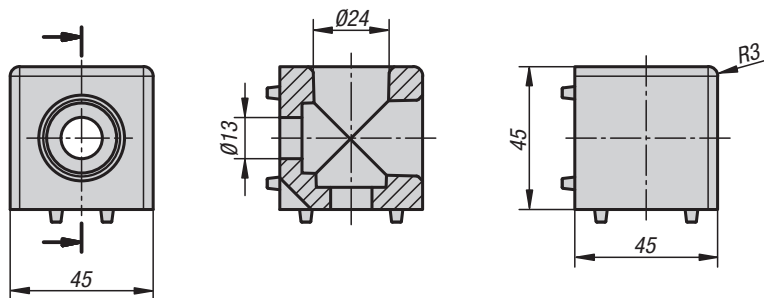

3-D

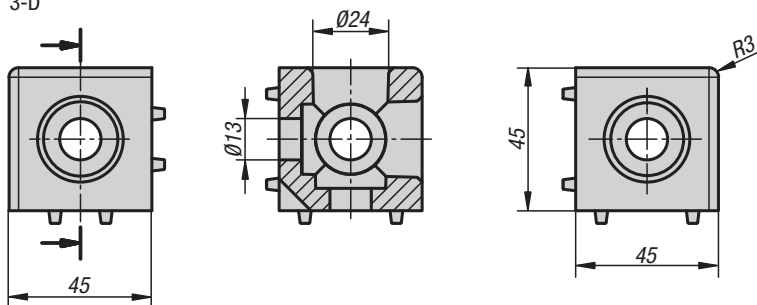
**Material:**

Cube die-cast aluminium.
Screws steel.
End caps polyamide.

Version:

Aluminium bright.
Screws with self-tapping thread.
End cap black.

Sample order:

K1039.102

Note:

The cube connector can be used to connect two or three profiles to each other by the end faces. The cube connectors have guide lugs that ensure a perfect and secure installation. Fastening to the profile is carried out by self-tapping screws. The open holes can be closed off with the end caps.

The profile slots positioned at right-angles to each other remain free. Panel elements can be positioned in the profile slots without additional machining.

**KIPP Cube connector sets Type B**

Order No.	Type	Slot width	Version
K1039.102	B	10	2-D
K1039.103	B	10	3-D

K1040

Central screw

Type B

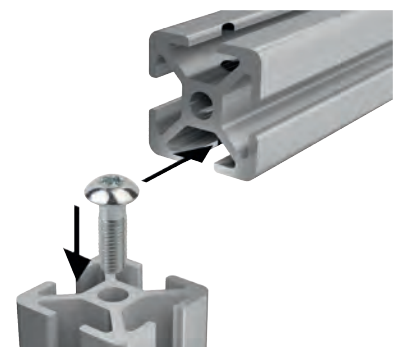
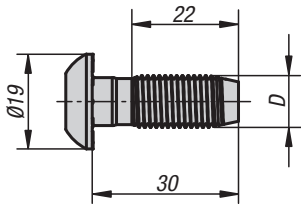
**Material:**
Steel.**Version:**
galvanized.**Sample order:**
K1040.1012**Note:**
Self-tapping screw for end face core hole. Ideal for fastenings without an angle or additional connectors not exposed to high loads.

KIPP Central screw Type B

Order No.	Type	Slot width	D	SW
K1040.1012	B	10	S12	T50

T-nuts

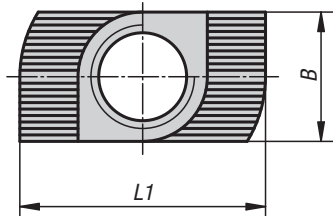
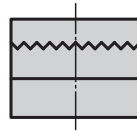
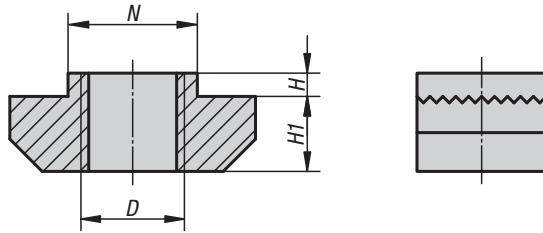

Material:
Steel.

Version:
galvanized.

Sample order:
K1028.0804015

Note:

Universal fastening element. The T-nut is twisted into the profile slot and so can be subsequently inserted into existing systems. The serrations break through the anodized film and creates a secure, electrical conductive connection.

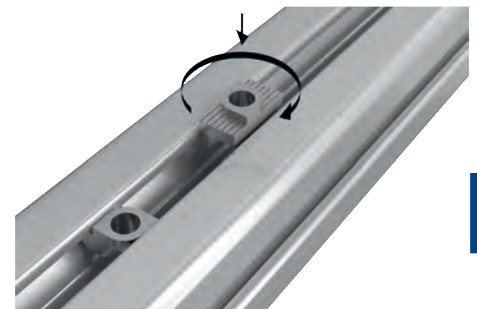

KIPP T-nuts

Order No.	Type	Slot width	D	N	B	H	H1	L1
K1028.0804015	B	8	M4	7,7	7,7	1,5	4,5	16
K1028.0805015	B	8	M5	7,7	7,7	1,5	4,5	16
K1028.0806015	B	8	M6	7,7	7,7	1,5	4,5	16
K1028.1004030	B	10	M4	9,7	9,7	3	5,8	19
K1028.1005017	-	10	M5	9,7	9,7	1,5	5,8	19
K1028.1005030	B	10	M5	9,7	9,7	3	5,8	19
K1028.1006017	-	10	M6	9,7	9,7	1,5	5,8	19
K1028.1006030	B	10	M6	9,7	9,7	3	5,8	19
K1028.1008017	-	10	M8	9,7	9,7	1,5	5,8	19
K1028.1008030	B	10	M8	9,7	9,7	3	5,8	19

Hammer-head screws

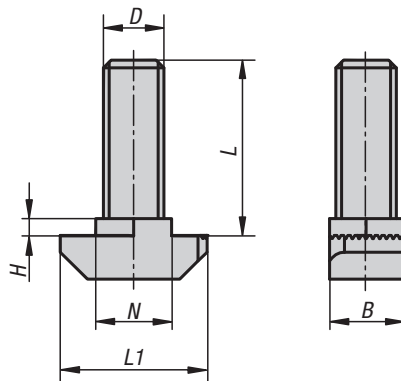

Material:
Steel.

Version:
galvanized.

Sample order:
K1029.0806015X16

Note:
Universal fastening element. The hammer-headed screw is twisted into the profile slot and so can be mounted into an existing system at a later date. The serrations break through the anodized film and create a secure, electrical conductive connection.

KIPP Hammer-head screws

Order No.	Type	Slot width	B	D	H	L	L1	N
K1029.0806015X16	B	8	7,7	M6	1,5	16	16	7,7
K1029.0806015X20	B	8	7,7	M6	1,5	20	16	7,7
K1029.0806015X25	B	8	7,7	M6	1,5	25	16	7,7
K1029.1008030X20	B	10	9,7	M8	3	20	19	9,7
K1029.1008030X25	B	10	9,7	M8	3	25	19	9,7
K1029.1008030X30	B	10	9,7	M8	3	30	19	9,7
K1029.1008030X40	B	10	9,7	M8	3	40	19	9,7
K1029.1008030X60	B	10	9,7	M8	3	60	19	9,7

K1030

Hexagon nuts with flange

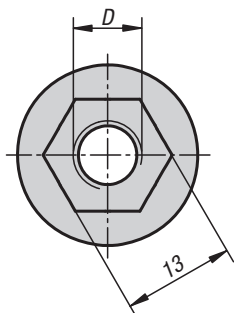
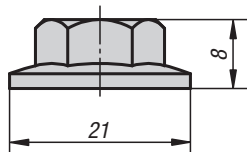
**Material:**
Steel.**Version:**
galvanized.**Sample order:**
K1030.08**Note:**
Nut with a large collar. Ideal together with a hammer-head screw.

KIPP Hexagon nuts with flange

Order No.	Type	Slot width	D
K1030.08	B	10	M8

K1041

Butt connector sets automatic

Type I

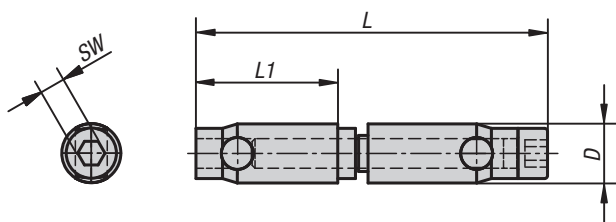
**Material:**
Steel.**Version:**
galvanized.**Sample order:**
K1041.06**Note:**
The connecting sets are used to connect two aluminum profiles of the same series from the front.

No machining of the profile is necessary. The connector is screwed into the profile slot from the front (connector with through hole left-hand thread. Connector with internal thread right-hand thread). The connector has a self-tapping thread. The use of lubricants is recommended.

KIPP Butt connector sets, automatic, Type I

Order No.	Type	Slot width	D	L	L1	SW
K1041.06	I	6	10	60	24	4
K1041.08	I	8	12	69	27	5

Automatic connecting sets should always be used in pairs. More pairs are required for large profiles and loads.



K1023

Slot nuts

twist-in Type I

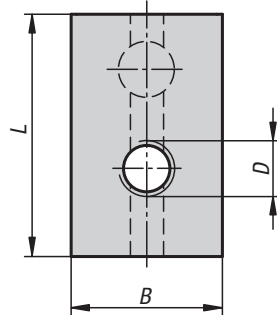
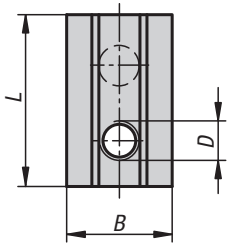
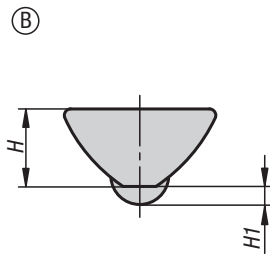
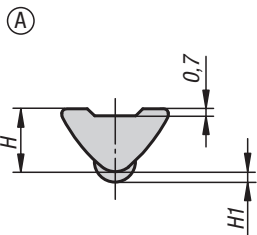

Material:
Steel.

Version:
galvanized.

Sample order:
K1023.0604

Note:
The slot nut is twisted into the profile slot and so can be subsequently inserted into existing systems. The spring-loaded ball allows the nut to be fixated anywhere in the profile slot.

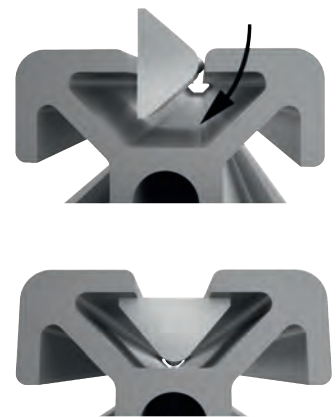

KIPP Slot nuts twist-in Type I

Order No.	Type	Slot width	Form	D	B	H	H1	L
K1023.0604	I	6	A	M4	10,5	6,3	1	17
K1023.0605	I	6	A	M5	10,5	6,3	1	17
K1023.0606	I	6	A	M6	10,5	6,3	1	17
K1023.0804	I	8	B	M4	13,7	7	1,7	22
K1023.0805	I	8	B	M5	13,7	7	1,7	22
K1023.0806	I	8	B	M6	13,7	7	1,7	22
K1023.0808	I	8	B	M8	13,7	7	1,7	22

K1024

Slot nuts

twist-in, keyed Type I

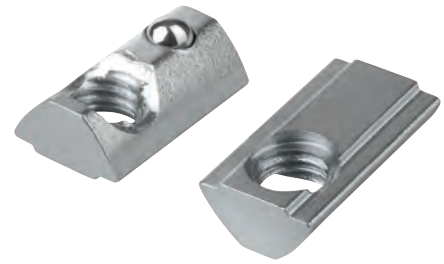
**Material:**
Steel.**Version:**
galvanized.**Sample order:**
K1024.0604**Note:**

The slot nut is twisted into the profile slot and so can be subsequently inserted into existing systems. The spring-loaded ball allows the nut to be fixated anywhere in the profile slot. The key centres the nut in the profile slot and keeps it neatly seated.

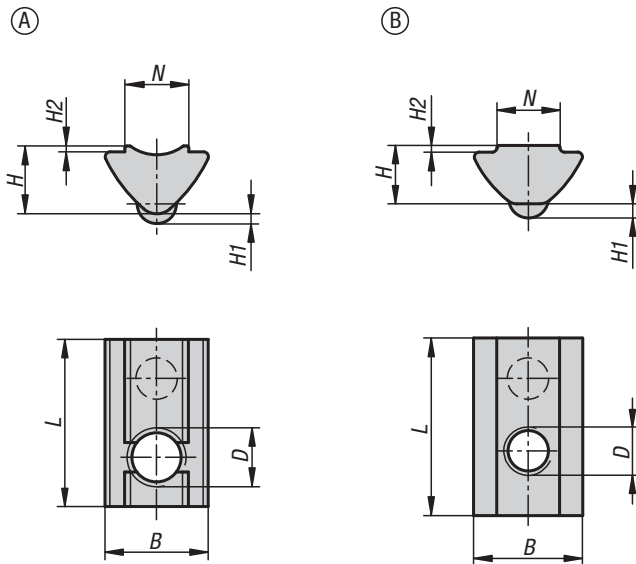

KIPP Slot nuts twist-in, keyed Type I

Order No.	Type	Slot width	Form	D	N	B	H	H1	H2	L
K1024.0604	I	6	A	M4	6,5	10,5	6,9	1	0,6	17
K1024.0605	I	6	A	M5	6,5	10,5	6,9	1	0,6	17
K1024.0606	I	6	A	M6	6,5	10,5	6,9	1	0,6	17
K1024.0803	I	8	B	M3	7,8	13,5	7,2	1,75	0,8	22
K1024.0804	I	8	B	M4	7,8	13,5	7,2	1,75	0,8	22
K1024.0805	I	8	B	M5	7,8	13,5	7,2	1,75	0,8	22
K1024.0806	I	8	B	M6	7,8	13,5	7,2	1,75	0,8	22
K1024.0808	I	8	B	M8	7,8	13,5	7,2	1,75	0,8	22

K1044

Fastening sets

for straps and angles

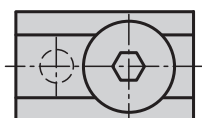
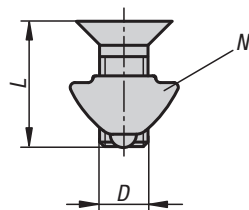
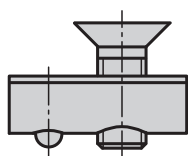
**Material:**
Steel.**Version:**
galvanized.**Sample order:**
K1044.06**Note:**
Consists of two DIN 7991 countersunk screws and two slot nuts.

KIPP Fastening sets for straps and angles

Order No.	Type	Slot width	Version	D	L
K1044.06	I	6	Slot key without step	M6	10
K1044.08	I	8	Slot key with step	M8	14

K1025

Slot keys

heavy duty Type I

**Material:**

Steel.

Version:

galvanized.

Sample order:

K1025.0804

Note:

Suitable for high load connections. Since the key passes to the slot form of the profile, forces are transferred to the profile. The total height allows more threads to be engaged. The slot key can only be inserted into the profile slot from the end. The spring-loaded ball allows the slot key to be fixated anywhere in the profile slot.

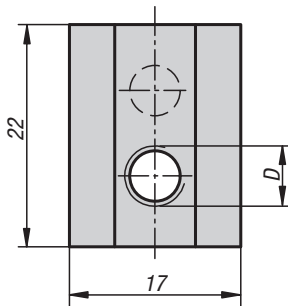
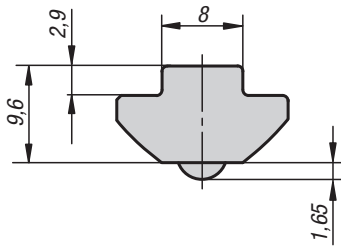

KIPP Slot keys heavy duty Type I

Order No.	Type	Slot width	D
K1025.0804	I	8	M4
K1025.0805	I	8	M5
K1025.0806	I	8	M6
K1025.0808	I	8	M8



K1026

Slot nuts

twist-in Type B

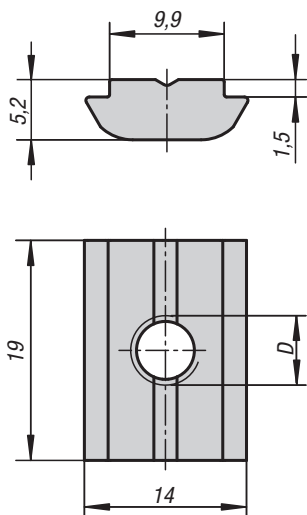
**Material:**

Steel.

Version:

galvanized.

Sample order:

K1026.1004

Note:

The slot nut is twisted into the profile slot and so can be subsequently inserted into existing systems.

KIPP Slot nuts twist-in Type B

Order No.	Type	Slot width	D
K1026.1004	B	10	M4
K1026.1005	B	10	M5
K1026.1006	B	10	M6
K1026.1008	B	10	M8

K1027

Slot nuts

twist-in with spring Type B

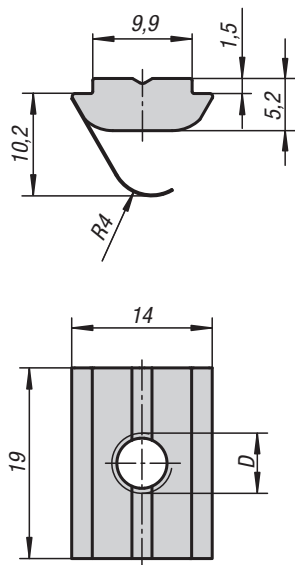
**Material:**
Steel.**Version:**
galvanized.**Sample order:**
K1027.1004**Note:**
The slot nut is twisted into the profile slot and so can be subsequently inserted into existing systems. The spring allows the nut to be fixated anywhere in the profile slot.

KIPP Slot nuts twist-in with spring Type B

Order No.	Type	Slot width	D
K1027.1004	B	10	M4
K1027.1005	B	10	M5
K1027.1006	B	10	M6
K1027.1008	B	10	M8